

[54] AQUARIUM FLOOR
[76] Inventor: Chester S. Turner, 13 Kingston Ave., Wakefield, R.I. 02879
[**] Term: 14 Years
[21] Appl. No.: 239,967
[22] Filed: Sep. 2, 1988
[52] U.S. Cl. D30/106
[58] Field of Search D30/101-107, D30/119; D11/145-146; 119/3, 5, 17, 19, 26, 29, 6.5, 15, 56.1, 70; D21/11, 18, 27, 201

3,121,417 2/1964 Goldman et al. D30/106
3,899,167 8/1975 Braunhut 119/5

Primary Examiner—James R. Largen
Assistant Examiner—Cathy Anne MacCormac
Attorney, Agent, or Firm—Jerry T. Kearns

[57] CLAIM

The ornamental design for an aquarium floor, as shown and described.

DESCRIPTION

FIG. 1 is a front elevational view of an aquarium floor showing my new design;
FIG. 2 is a rear elevational view thereof;
FIG. 3 is a left side elevational view thereof;
FIG. 4 is a right side elevational view thereof;
FIG. 5 is a top plan view thereof; and,
FIG. 6 is a bottom plan view thereof.
The broken line representation of indicia in FIGS. 1-4 is for illustrative purposes only and forms no part of the claimed design.

[56] References Cited
U.S. PATENT DOCUMENTS

D. 251,228 3/1979 Block et al. D21/11
D. 257,446 10/1980 Matsumoto D21/27
D. 267,891 2/1983 Hailey D21/27
2,130,820 9/1938 Trumbull D21/201
2,421,220 5/1947 Robinson, 2d et al. D21/11

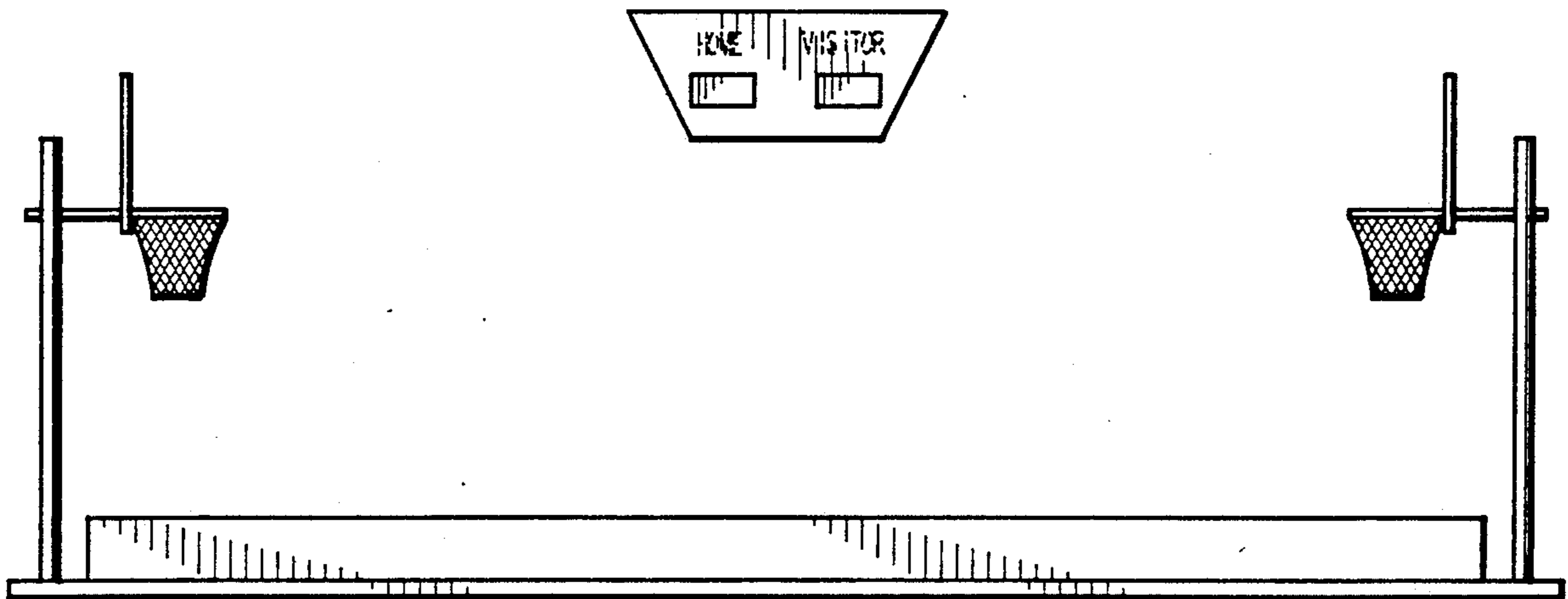

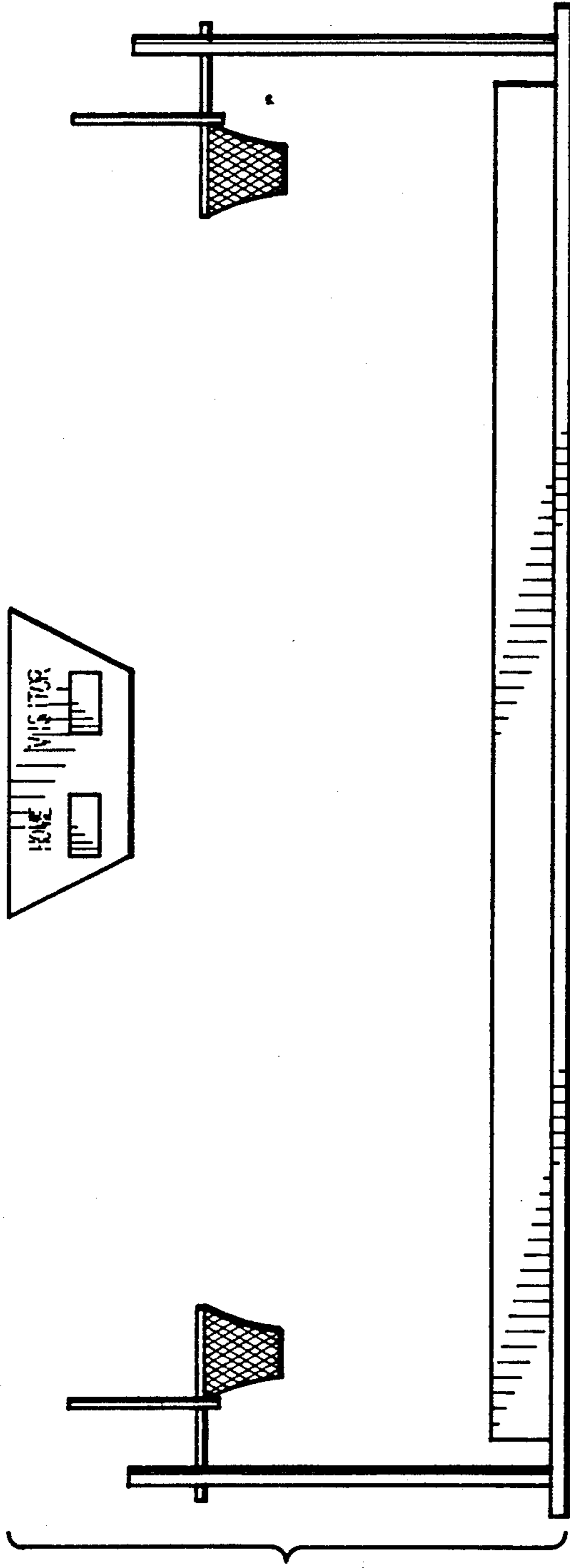

Fig. 1

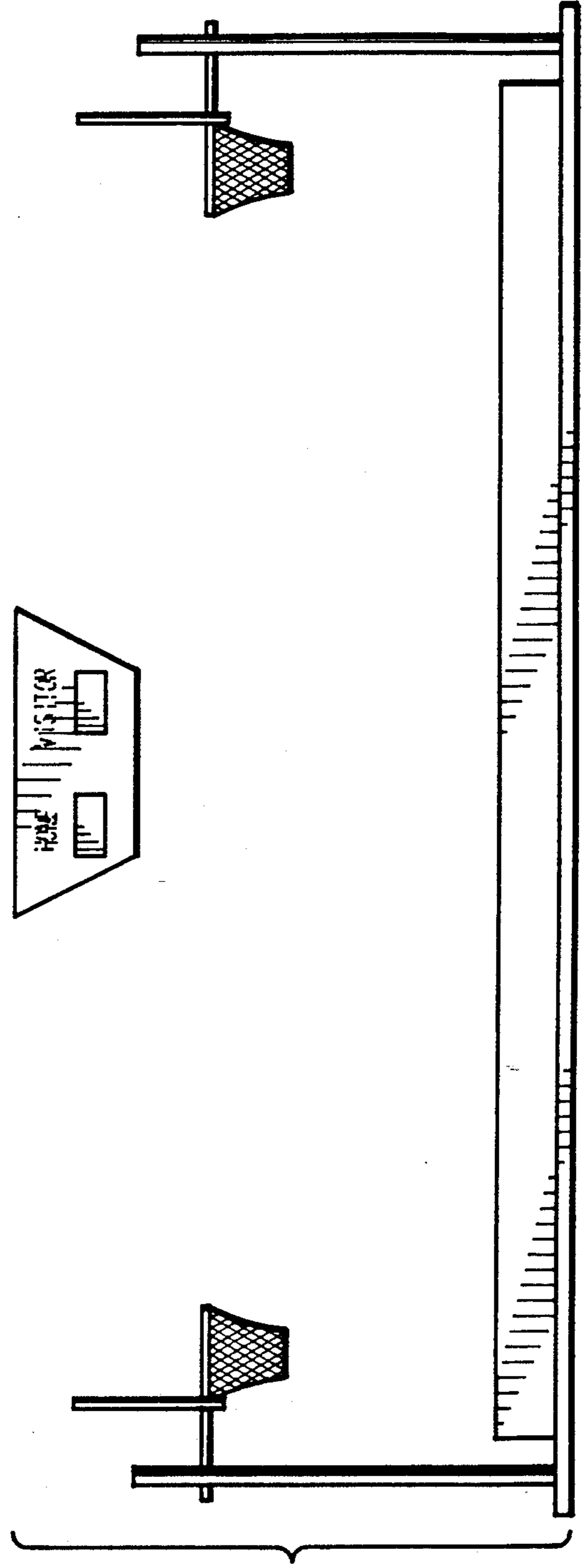

Fig. 2

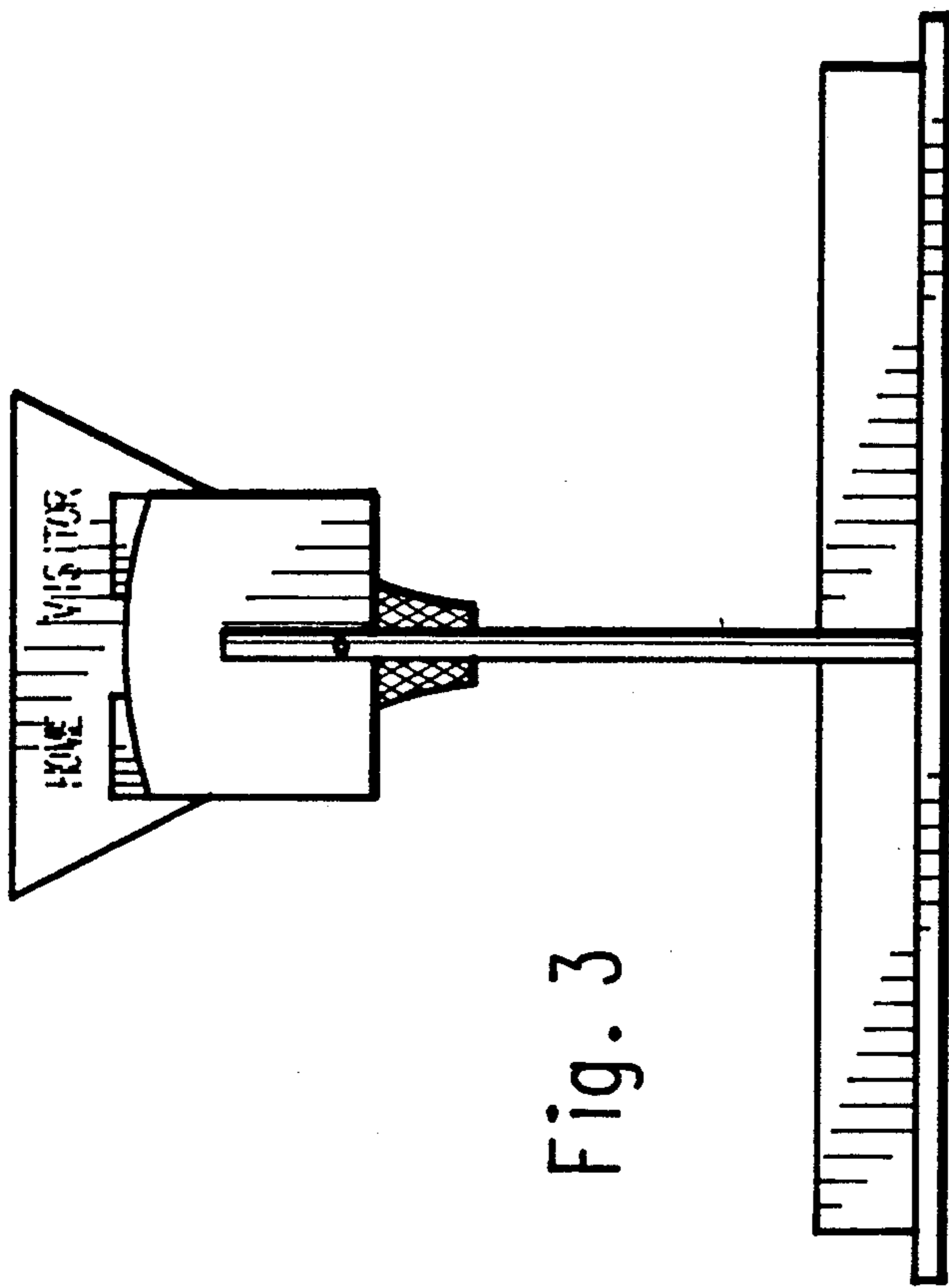

Fig. 3

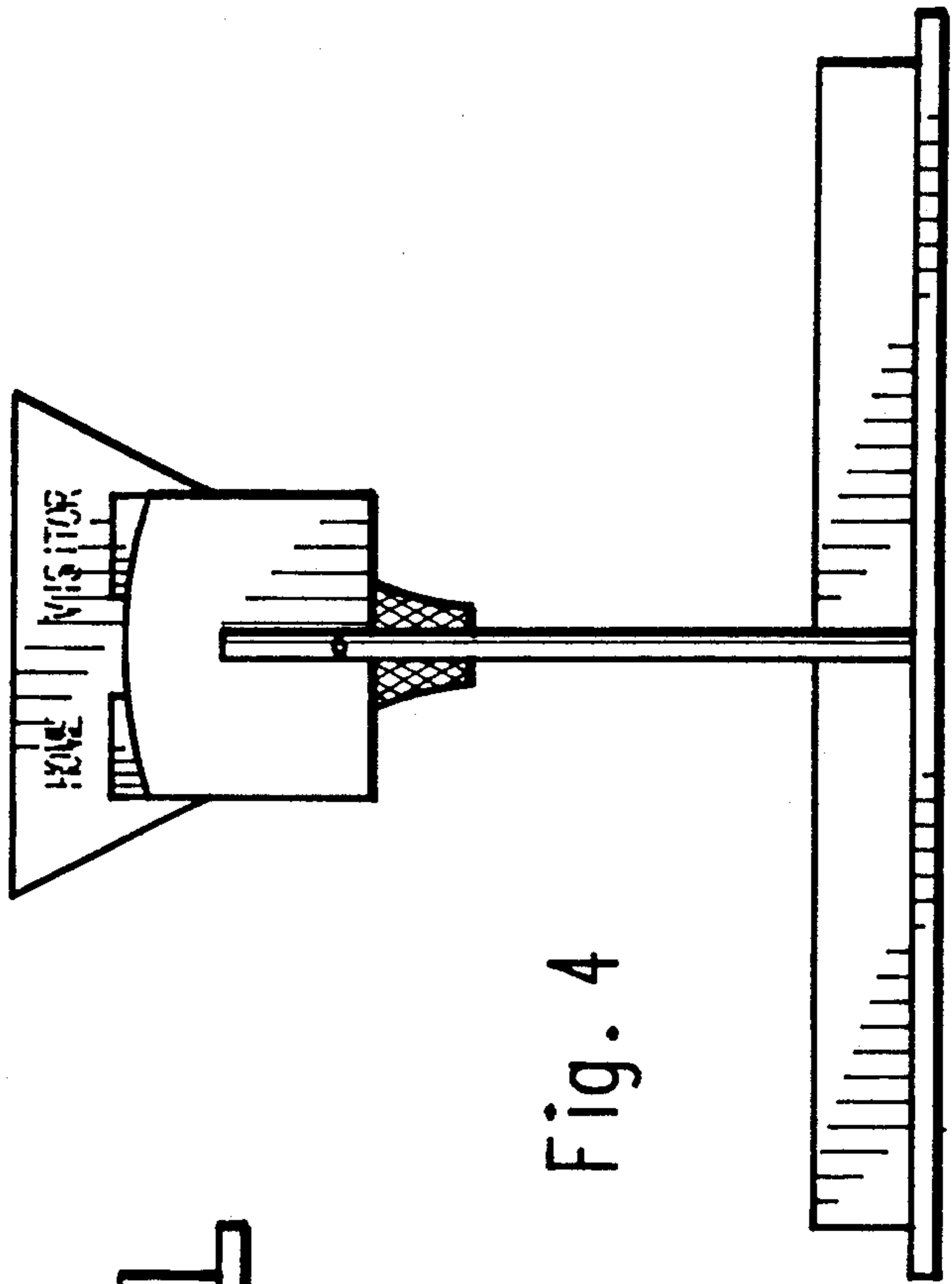

Fig. 4

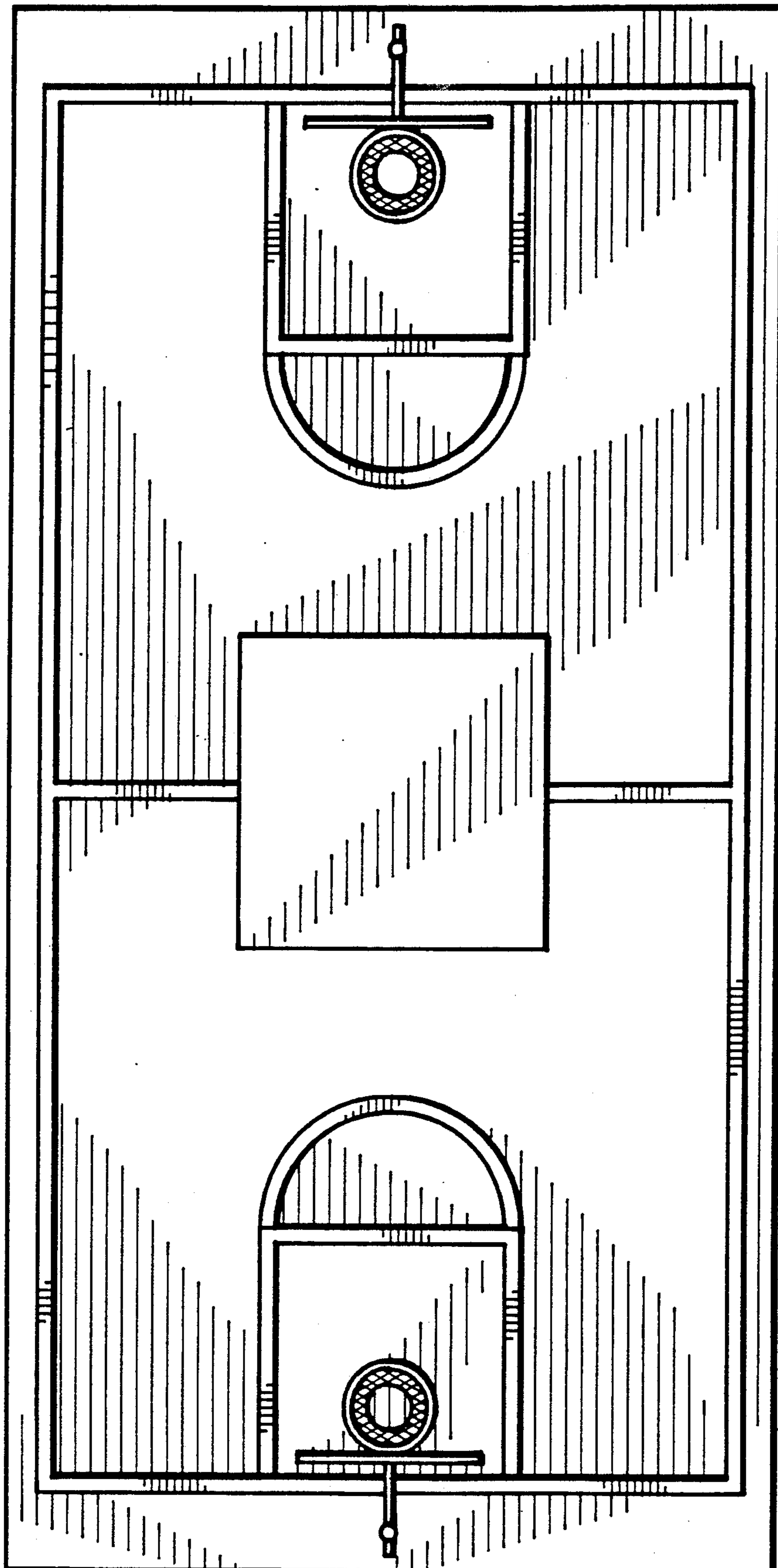

Fig. 5

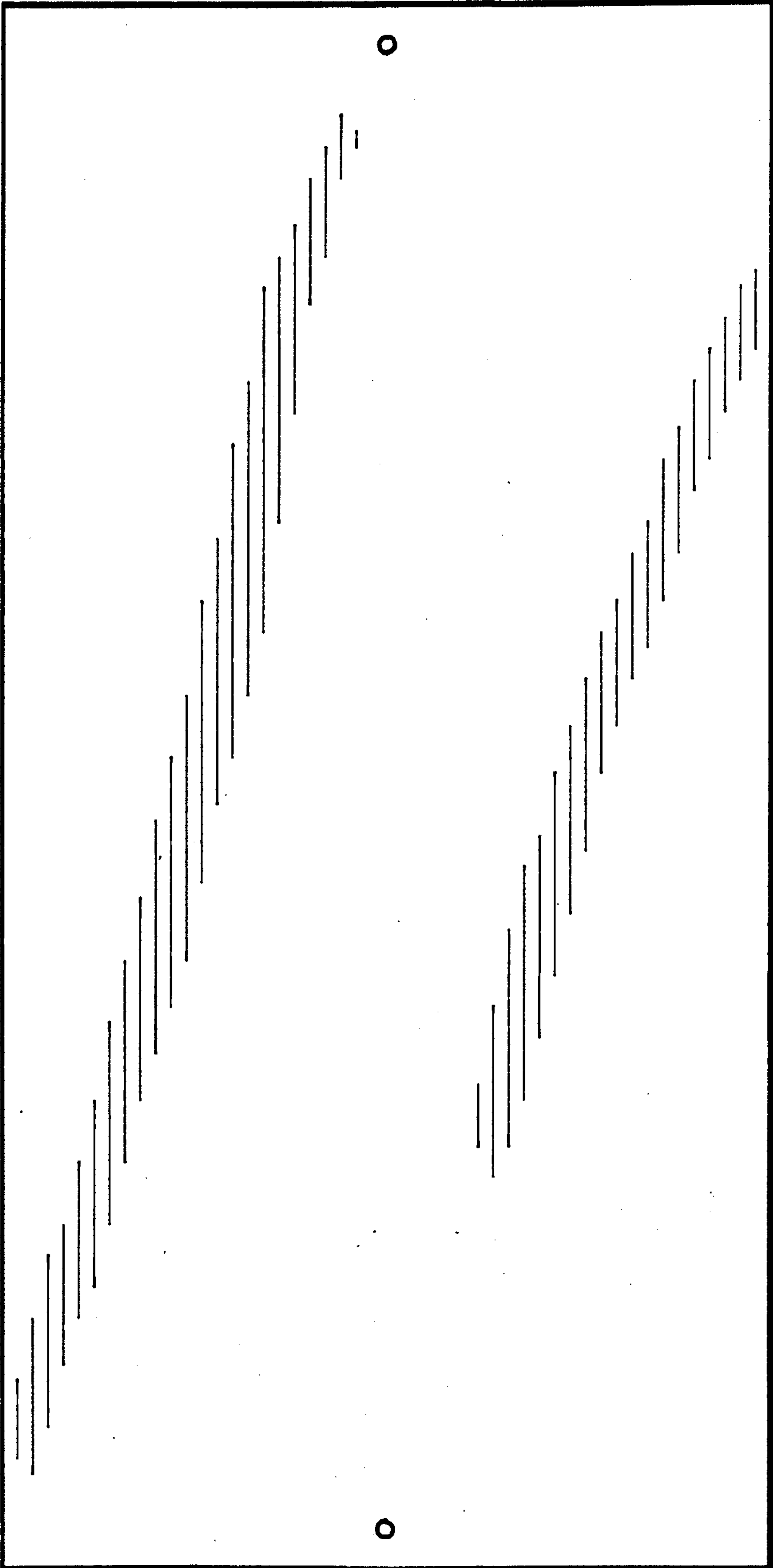

Fig. 6