

- [54] **RECREATIONAL BOAT**
- [75] **Inventors: Michael W. Lathers, Tustin; Thomas D. Wenstadt; Thomas M. Dekker, both of Cadillac, all of Mich.**
- [73] **Assignee: Outboard Marine Corporation, Waukegan, Ill.**
- [\*\*] **Term: 14 Years**
- [21] **Appl. No.: 413,059**
- [22] **Filed: Sep. 27, 1989**
- [52] **U.S. Cl. .... D12/314**
- [58] **Field of Search ..... D12/300, 310, 311, 314, D12/315, 318; 114/56, 355, 356, 357, 358, 343, 364, 271, 283, 288, 289, 290, 291**

- D. 245,409 8/1977 Bostic et al. .... D12/62
- D. 245,902 9/1977 Rogers ..... D12/62
- D. 246,234 11/1977 Whitley et al. .... D12/62
- D. 251,834 5/1979 Wood ..... D12/62
- D. 257,558 11/1980 Arima ..... D12/62
- D. 261,128 10/1981 Fowler ..... D12/300
- D. 263,133 2/1982 Watson ..... D12/315
- D. 263,134 2/1982 Watson ..... D12/314
- D. 267,866 2/1983 Parsons ..... D12/311
- D. 276,147 10/1984 Arima ..... D12/314
- D. 284,183 6/1986 Hegg et al. .... D12/314
- D. 284,566 7/1986 Hegg et al. .... D12/313
- D. 288,087 2/1987 Hegg et al. .... D12/315
- D. 294,343 2/1988 Scarboro ..... D12/314
- D. 296,206 6/1988 Arima ..... D12/314
- 3,117,544 5/1961 Schoell ..... 114/56

[56] **References Cited**

**U.S. PATENT DOCUMENTS**

- D. 186,480 10/1959 Cole et al. .... D71/1
- D. 188,148 6/1960 Tritt ..... D71/1
- D. 196,211 9/1963 Rowland ..... D71/1
- D. 202,591 10/1965 Lowe ..... D71/1
- D. 204,523 4/1966 Cole ..... D71/1
- D. 205,019 6/1966 Heintze ..... D71/1
- D. 205,604 8/1966 Stamas ..... D71/1
- D. 210,431 3/1968 Raschke ..... D71/1
- D. 214,101 5/1969 Simpkins ..... D71/1
- D. 219,118 11/1970 Baker ..... D71/1
- D. 221,808 9/1971 Simpkins ..... D71/1
- D. 234,349 2/1975 Cole ..... D12/62
- D. 234,685 4/1975 Cole ..... D12/62
- D. 235,530 6/1975 Livingston ..... D12/62
- D. 236,332 8/1975 Livingston ..... D12/62
- D. 236,333 8/1975 Livingston ..... D12/62
- D. 244,769 6/1977 Nescher ..... D12/62

**OTHER PUBLICATIONS**

1988 Four Winns Brochure entitled "The Four Winns Story".

1989 Sport Boats Brochure entitled "Sea Ray".

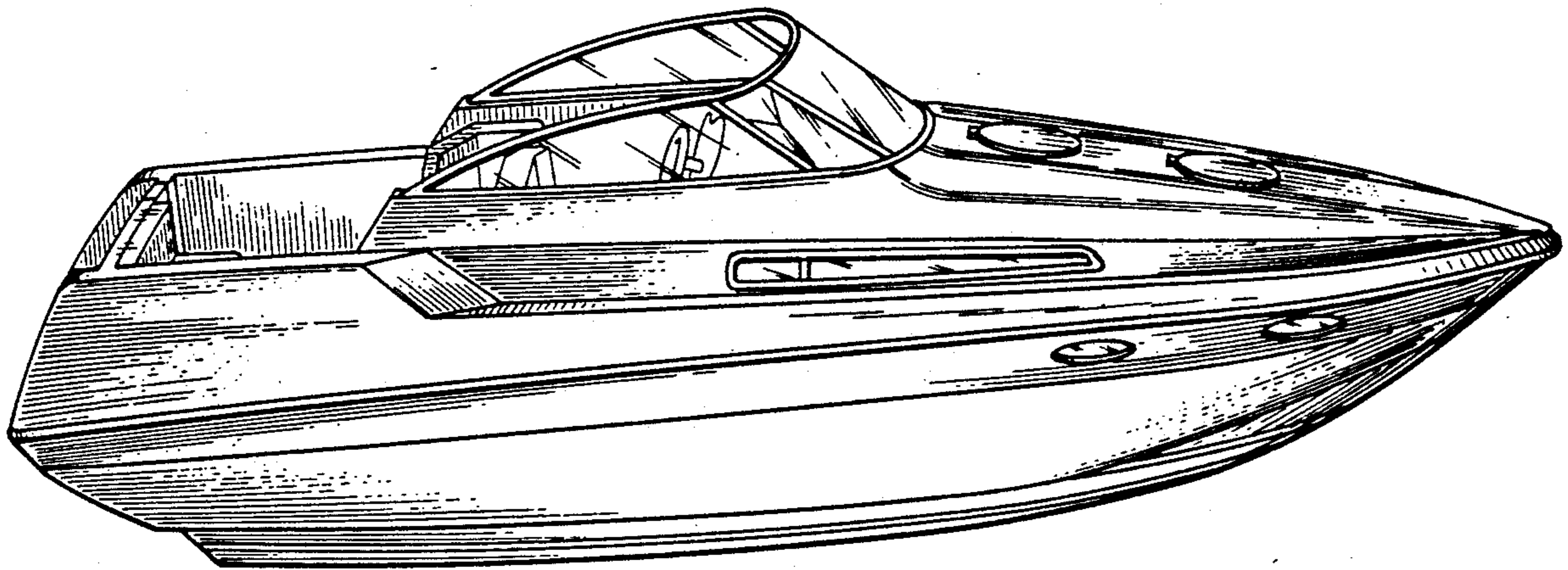
*Primary Examiner*—Kay H. Chin  
*Attorney, Agent, or Firm*—Michael, Best & Friedrich

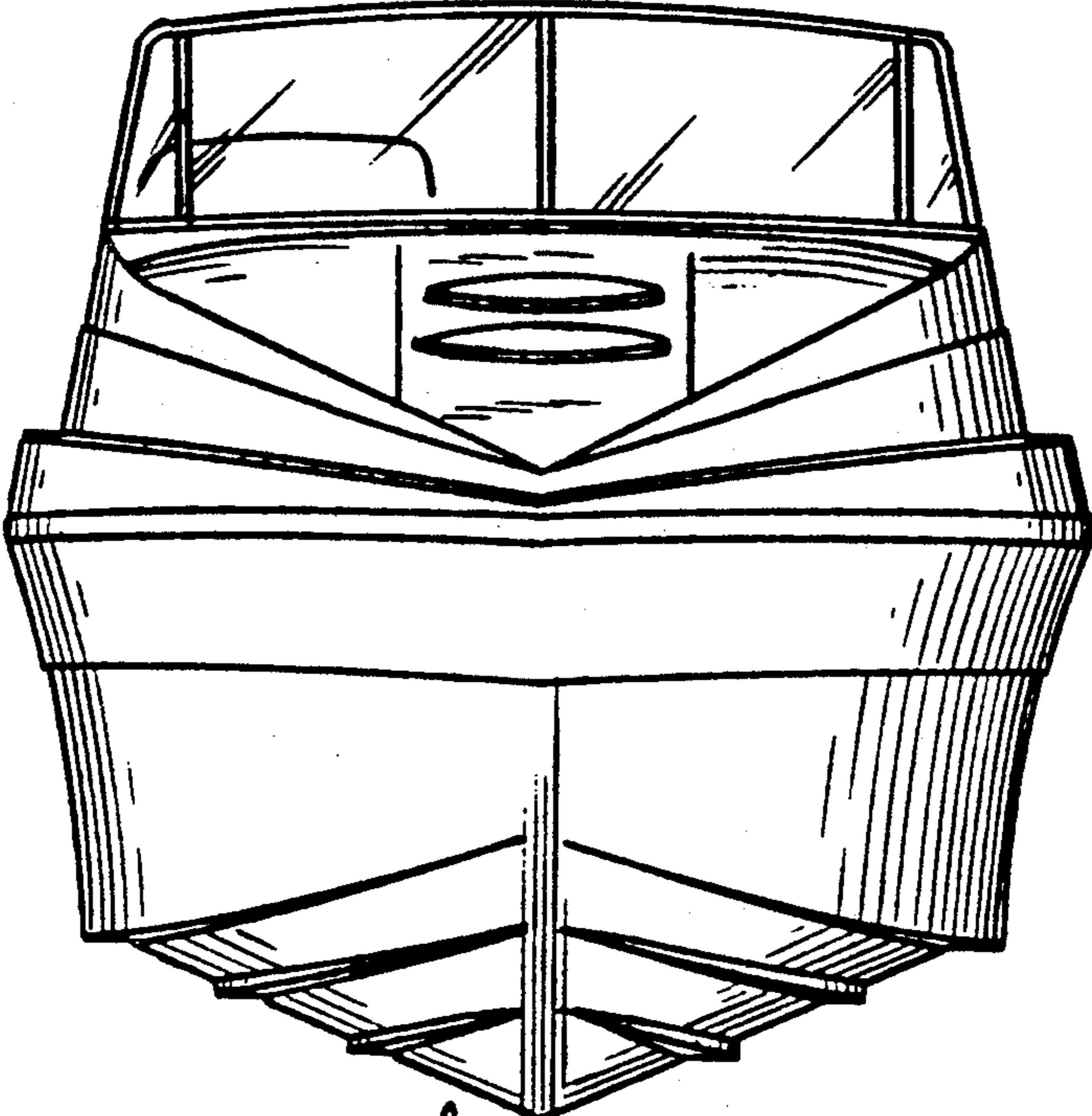
[57] **CLAIM**

The ornamental design for a recreational boat, as shown and described.

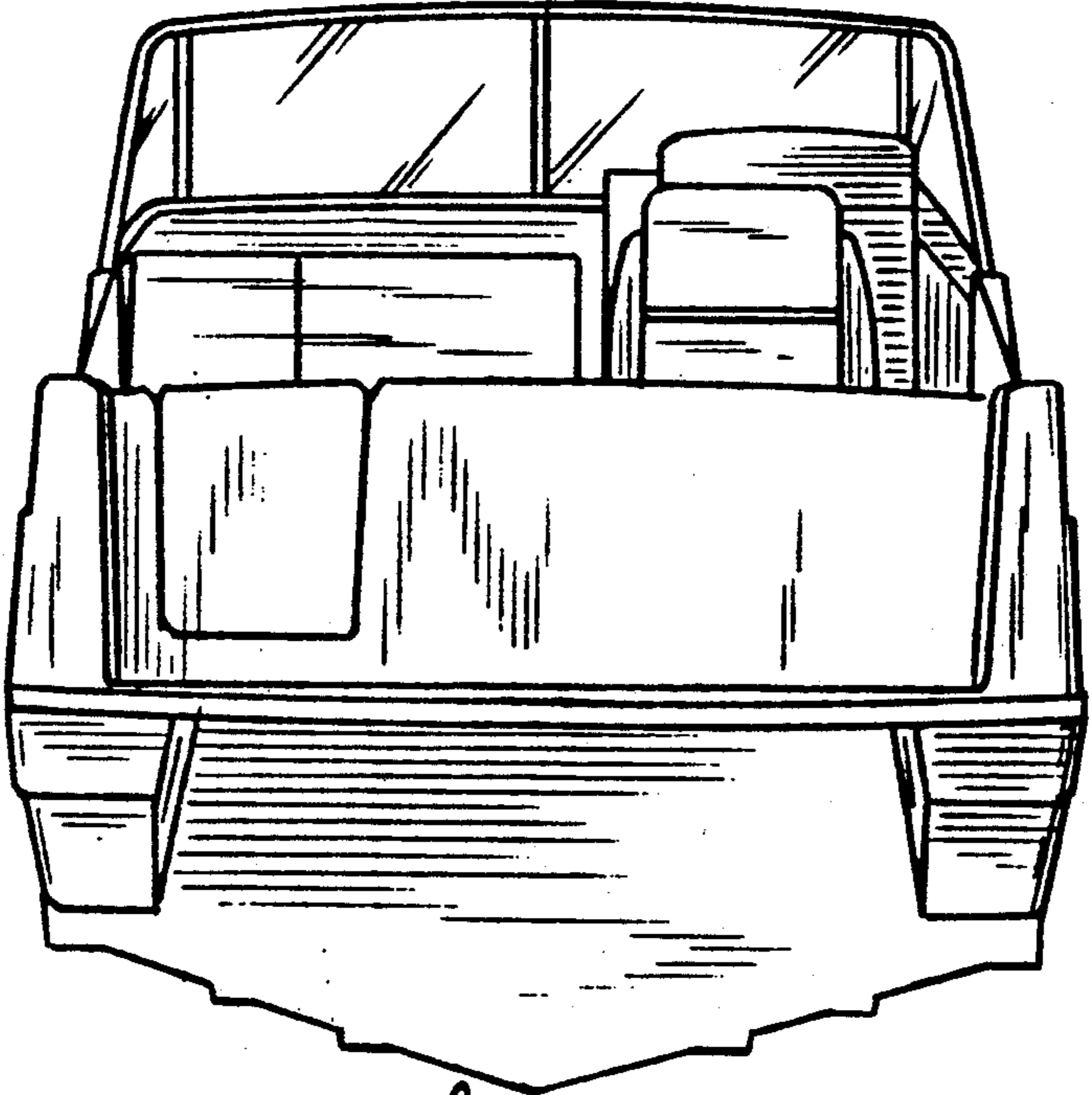
**DESCRIPTION**

FIG. 1 is a side elevational view of a recreational boat showing our new design, the opposite side elevational view being a mirror image of that shown; FIG. 2 is a front elevational view thereof; FIG. 3 is a top plan view thereof; FIG. 4 is a bottom plan view thereof; FIG. 5 is a rear elevational view thereof; and FIG. 6 is a top and side perspective view thereof.

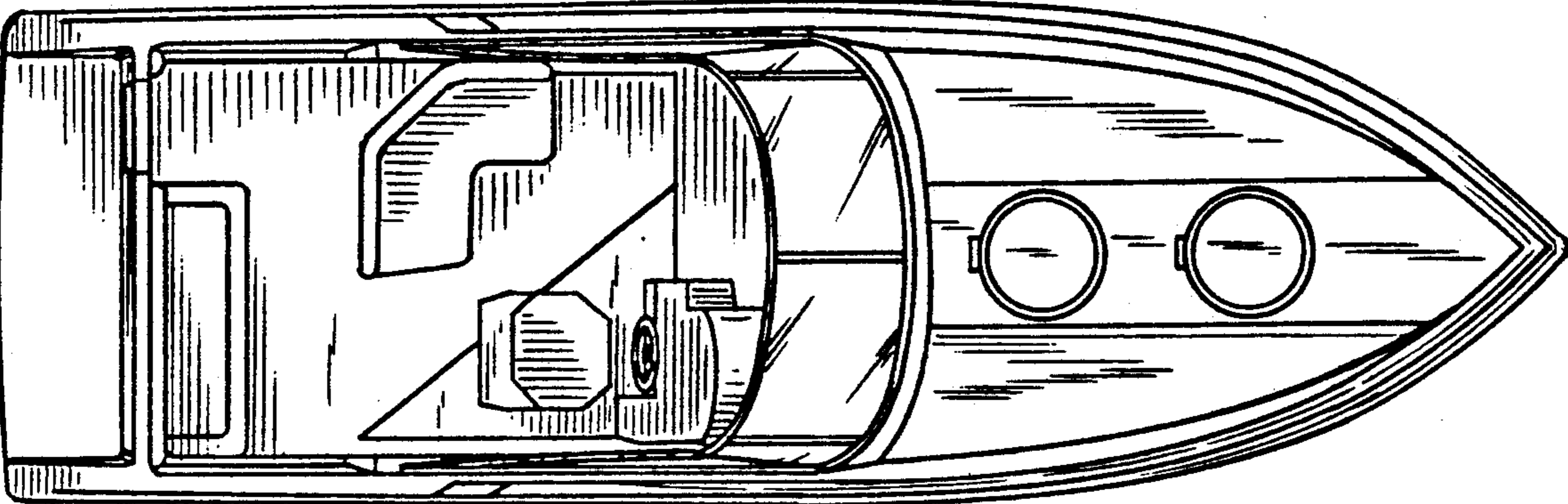




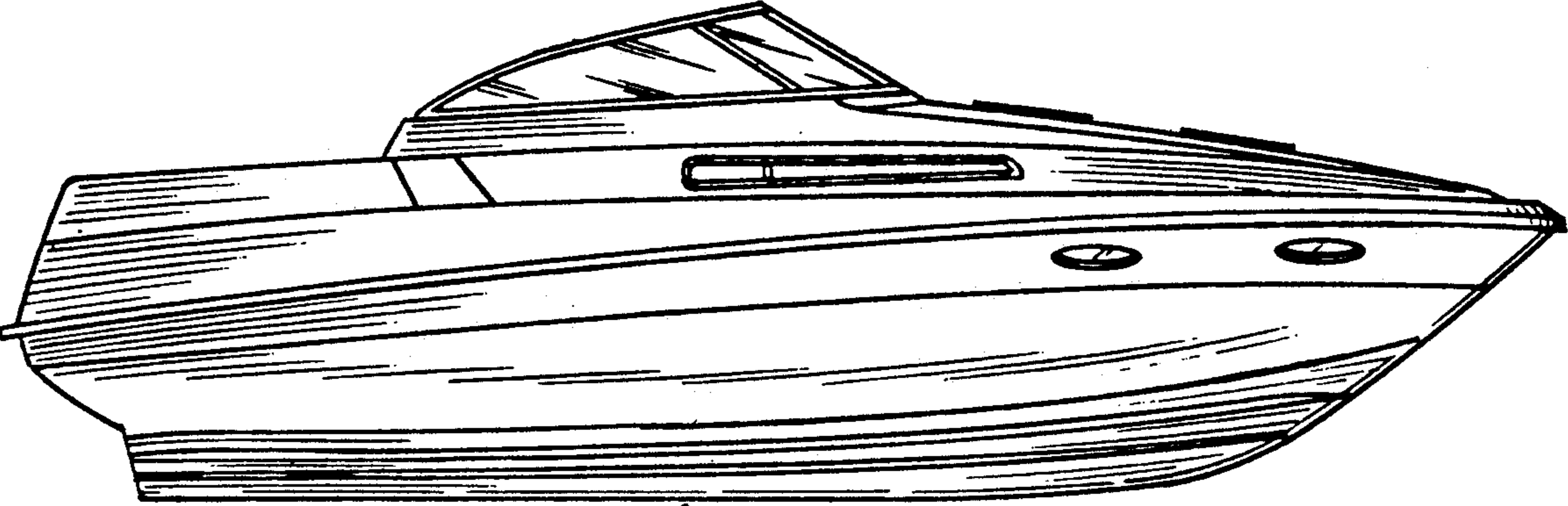
*Fig. 2*



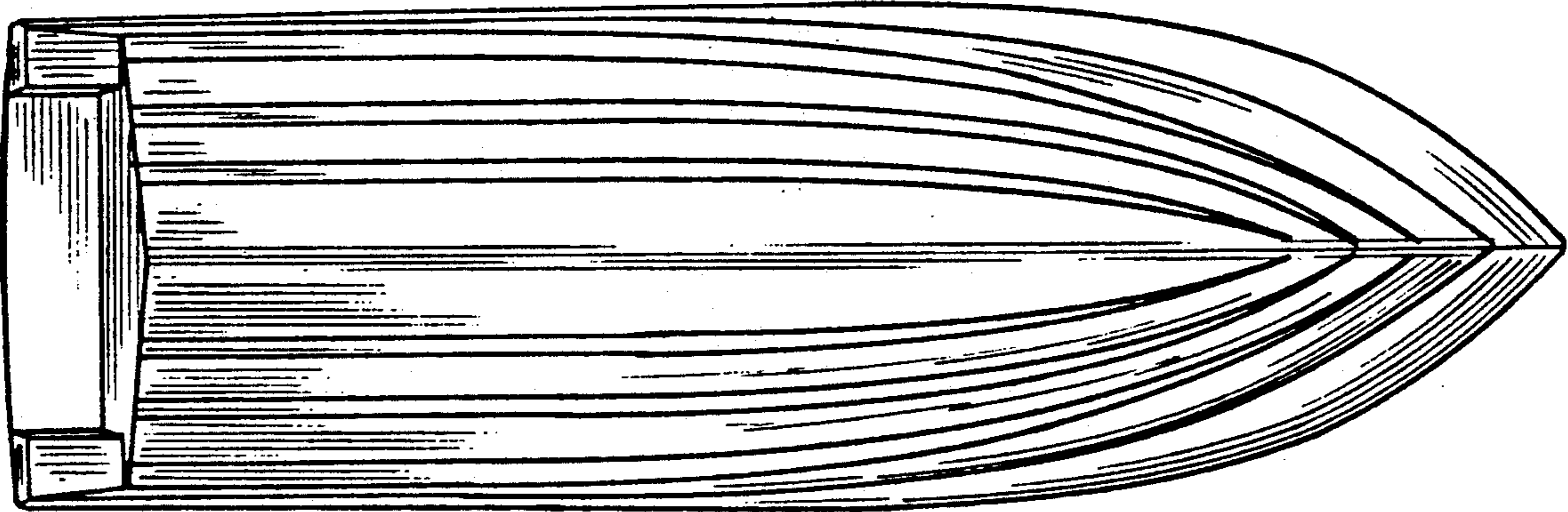
*Fig. 5*



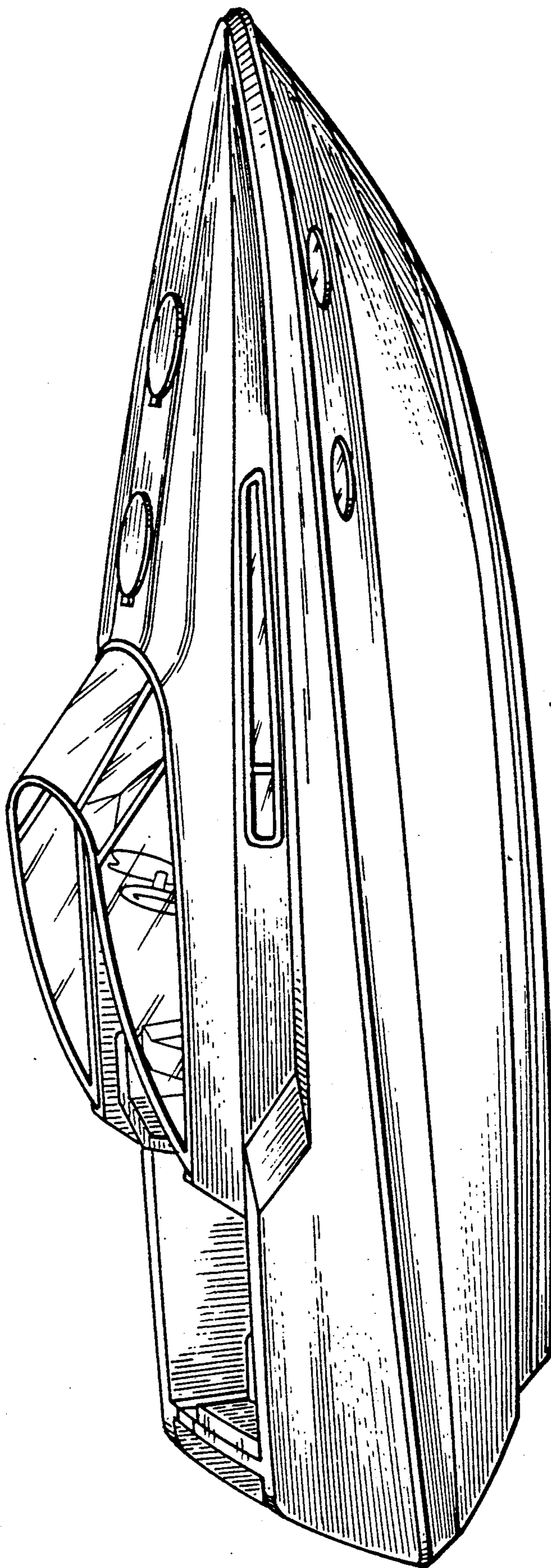
*fig. 3*



*fig. 2*



*fig. 1*



*Fig. 6*