

[54] WHEEL ASSEMBLY AND ATTACHMENT FOR A BOAT

[76] Inventor: John L. Salvesen, 8310 - 19th Ave. NW., Seattle, Wash. 98117

[\*\*] Term: 14 Years

[21] Appl. No.: 81,899

[22] Filed: Aug. 5, 1987

[52] U.S. Cl. .... D34/12; D12/135; D34/28

[58] Field of Search ..... D34/28, 12, 23, 24, D34/26; 280/47.131, 414.2, 414.5; D12/135, 148, 150; 114/344

[56] References Cited

U.S. PATENT DOCUMENTS

D. 294,418	2/1988	Salvesen .	
3,659,868	5/1972	Tucker .....	114/344
3,841,662	10/1974	Howell .....	114/344
4,036,507	7/1977	Henderson .....	114/344
4,480,578	11/1984	Fisher et al. ....	114/344
4,706,983	11/1987	Griswold .....	114/344

FOREIGN PATENT DOCUMENTS

1546817	11/1968	France .....	114/344
---------	---------	--------------	---------

Primary Examiner—Kay H. Chin

[57] CLAIM

The ornamental design for a wheel assembly and attachment for a boat, as shown and described.

DESCRIPTION

FIG. 1 is a front perspective view of a wheel assembly and attachment for a boat showing my new design; FIG. 2 is a left side elevational view thereof, the handle being removed for convenience of illustration; FIG. 3 is a left side elevational view of FIG. 2 showing the wheel in a raised condition; FIG. 4 is a front elevational view of FIG. 2; FIG. 5 is a rear elevational view of FIG. 2; FIG. 6 is a top plan view of FIG. 2; FIG. 7 is a bottom plan view of FIG. 2; FIG. 8 is a right side elevational view of FIG. 2; FIG. 9 is a front perspective view of a second embodiment of the wheel assembly and attachment for a boat, the sole difference from the first embodiment being in the different configuration of attachment of the wheel assembly; FIG. 10 is a left side elevational view of FIG. 9; the handle being removed for convenience of illustration; FIG. 11 is a left side elevational view of FIG. 10 showing the wheel in a raised condition; FIG. 12 is a bottom plan view of the attachment, the wheel assembly being removed for clarity of illustration; FIG. 13 is a front elevational view of FIG. 12; and FIG. 14 is a rear elevational view of FIG. 12. The broken lines shown in FIGS. 1, 3, 9, 10, and 11 are for illustrative purposes only and form no part of the claimed design.

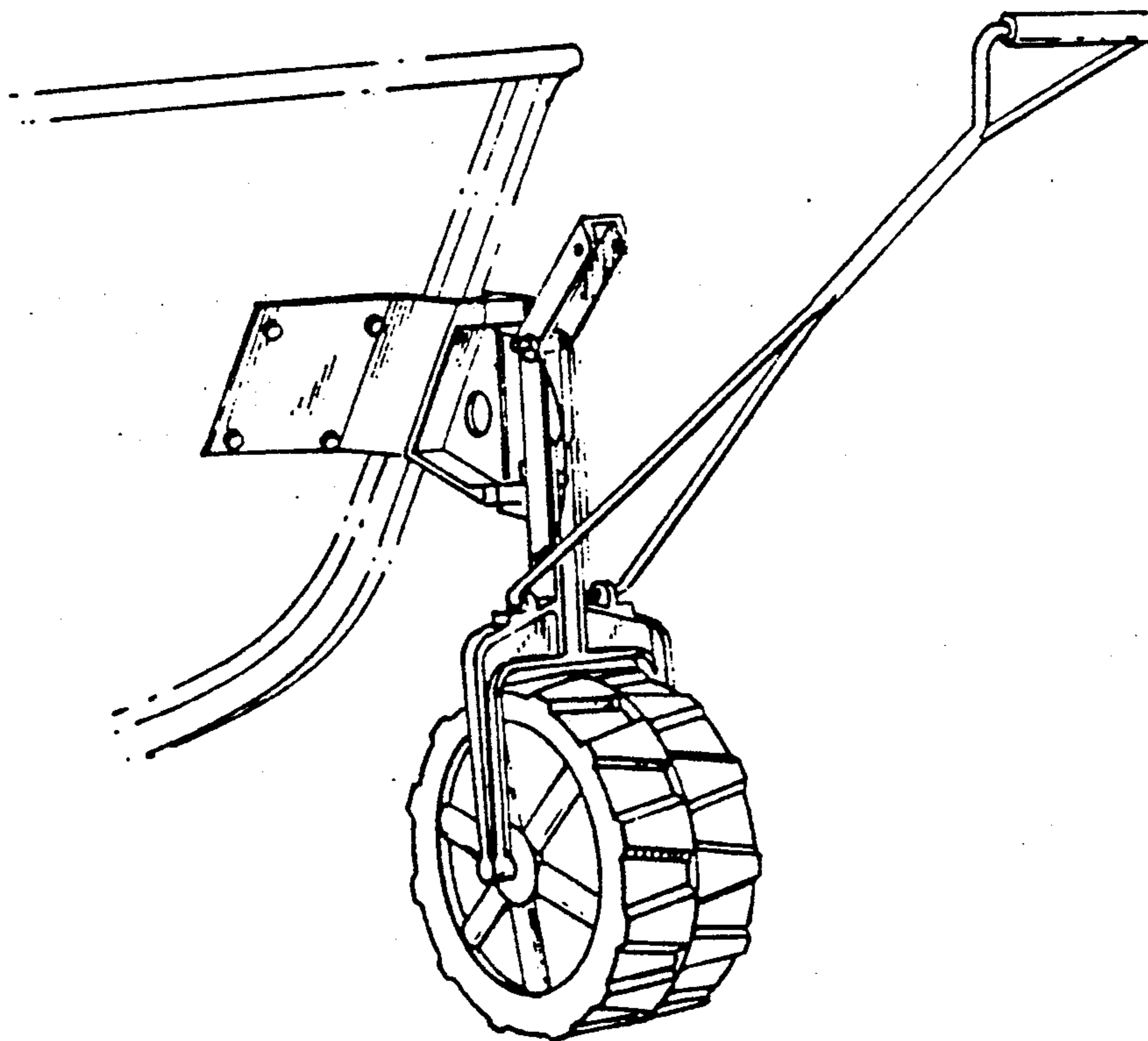

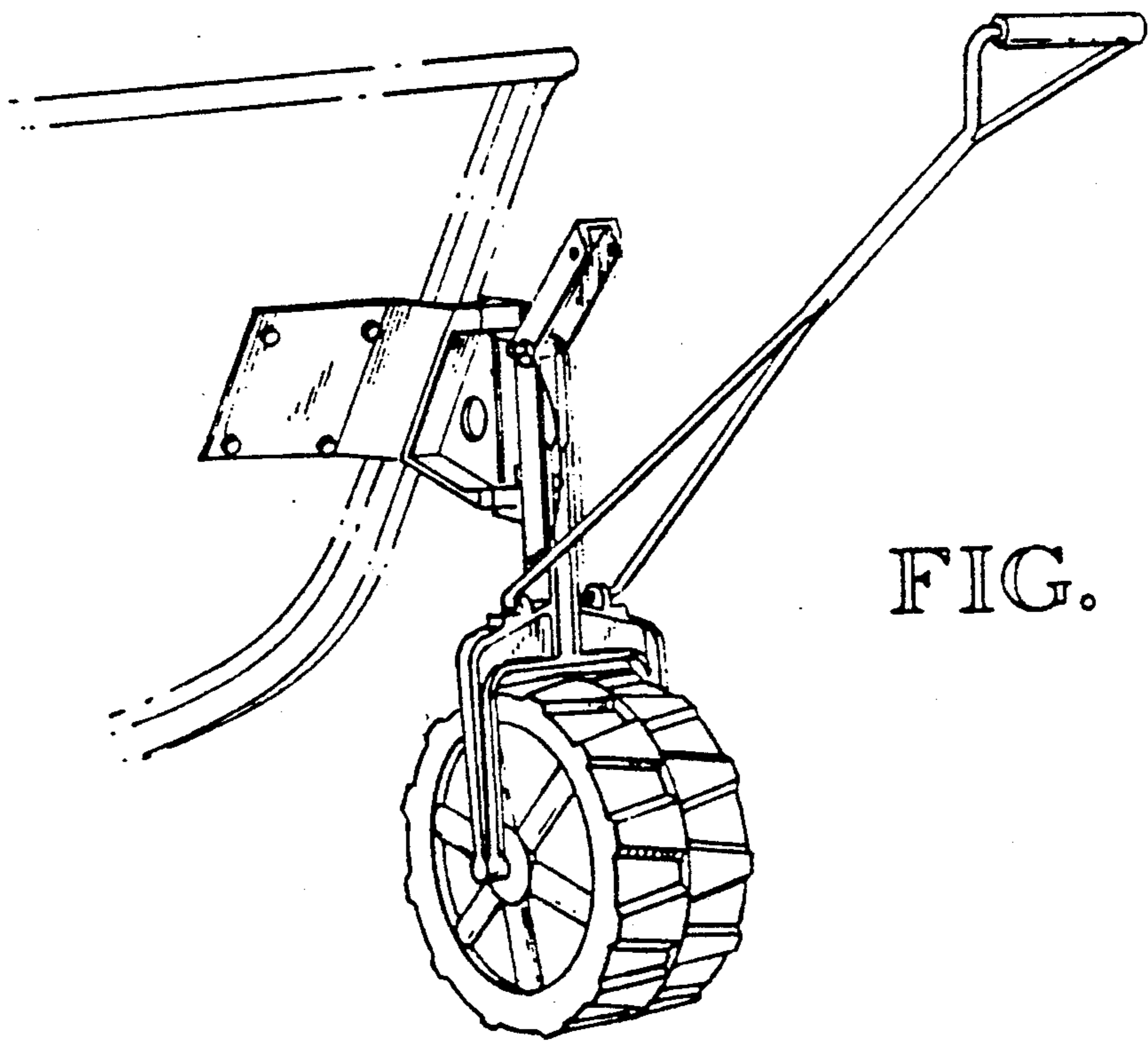

FIG. 1

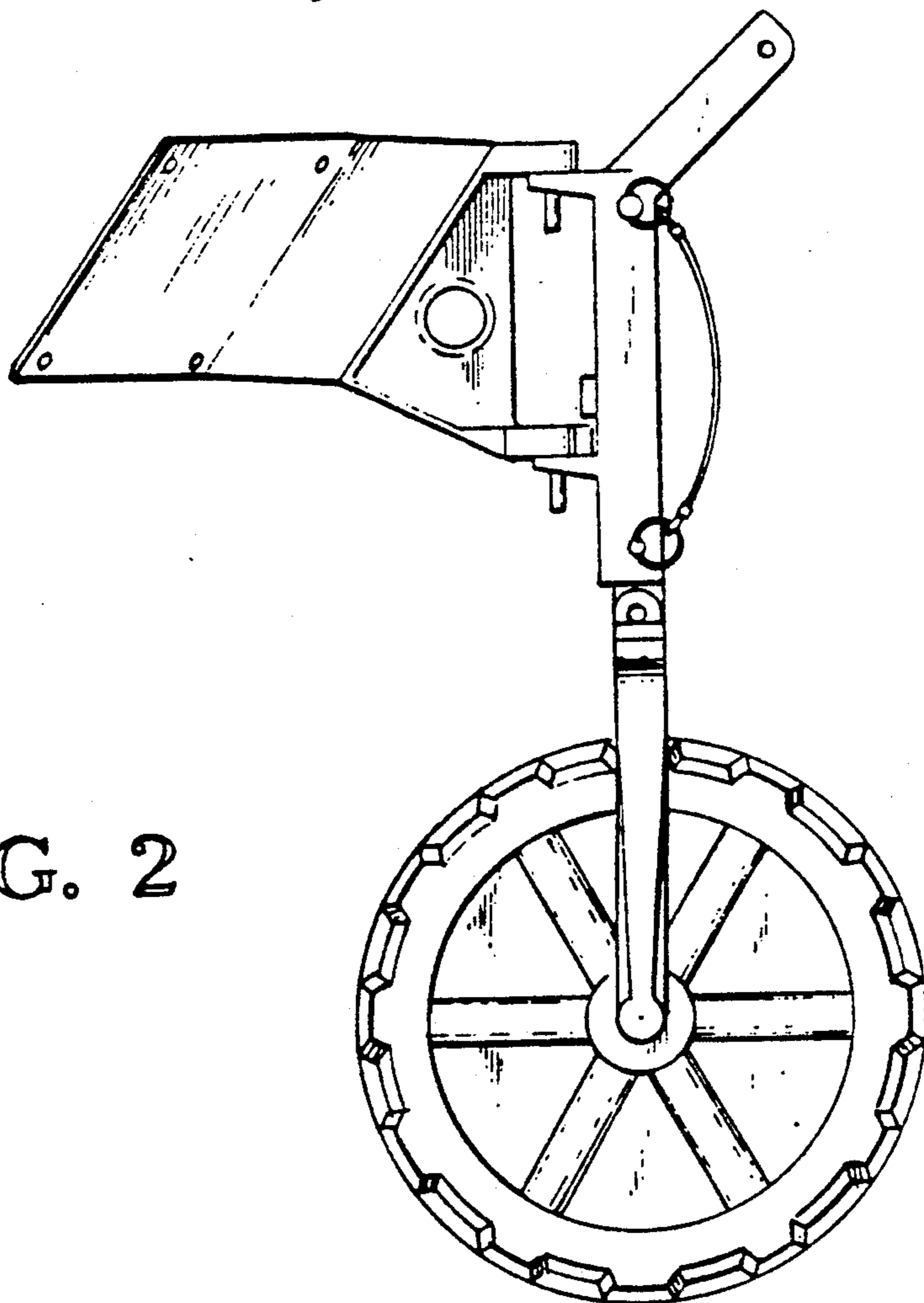

FIG. 2

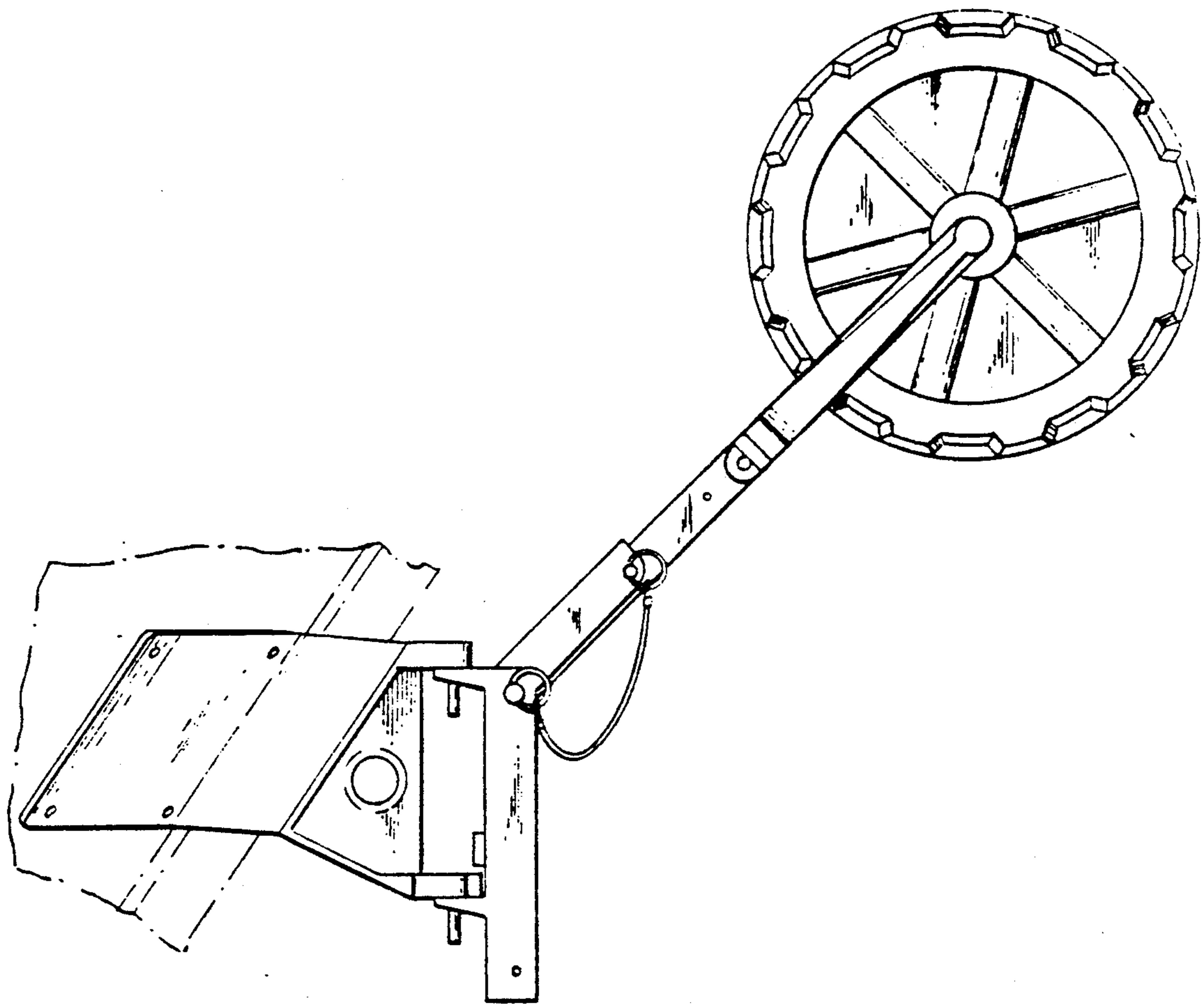

FIG. 3

FIG. 4

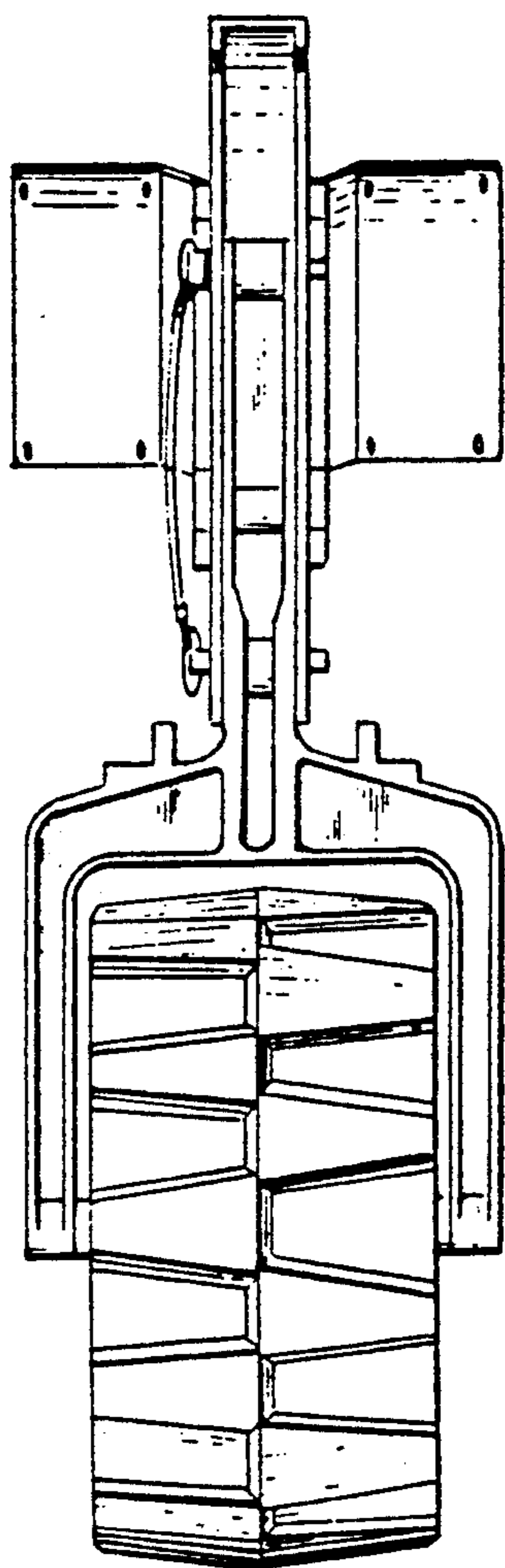

FIG. 5

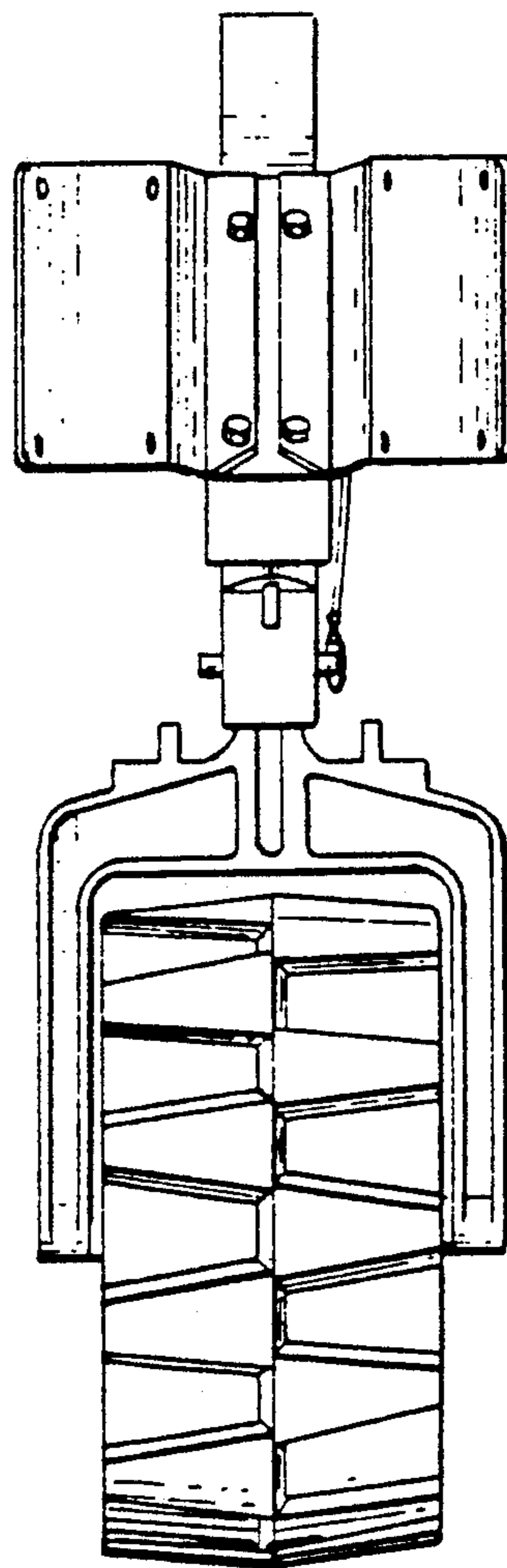

FIG. 6

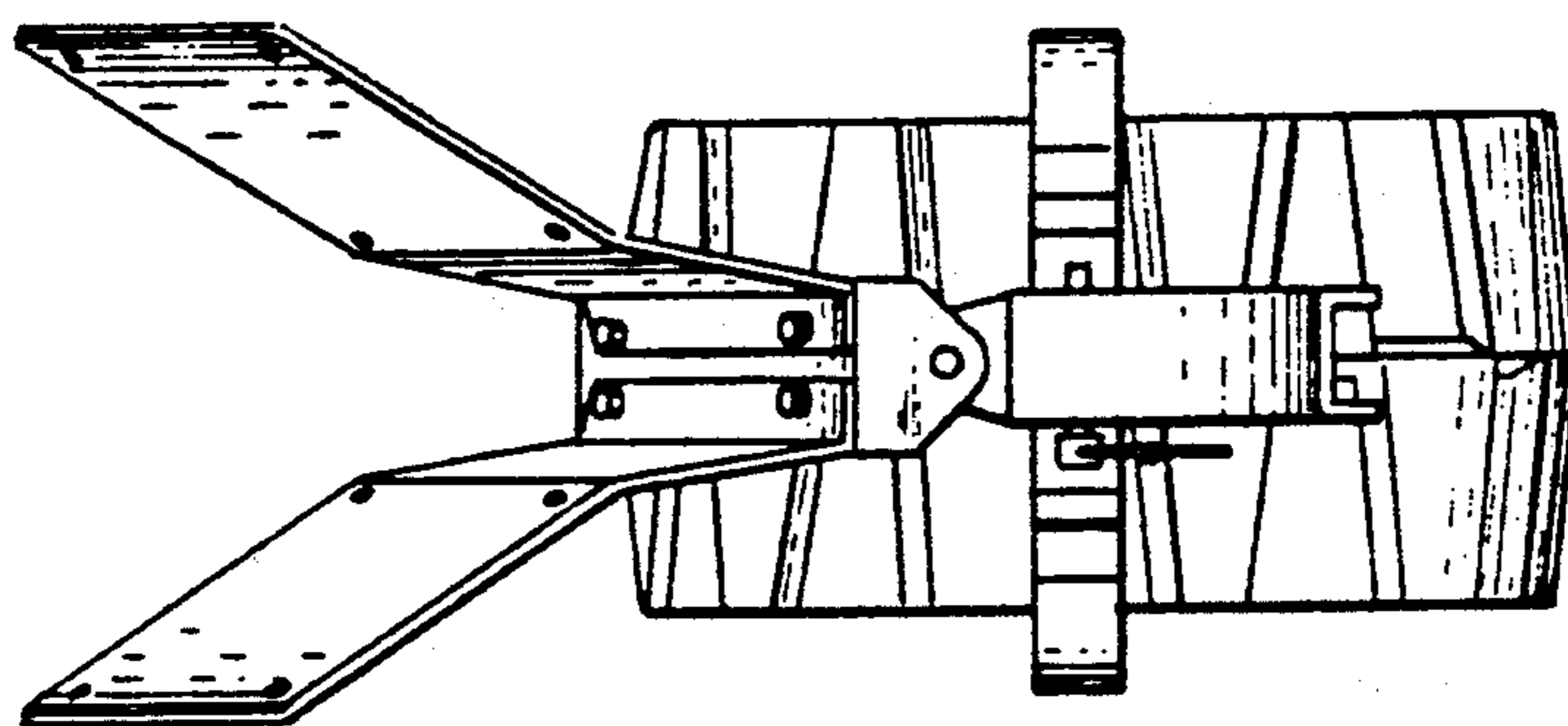

FIG. 7

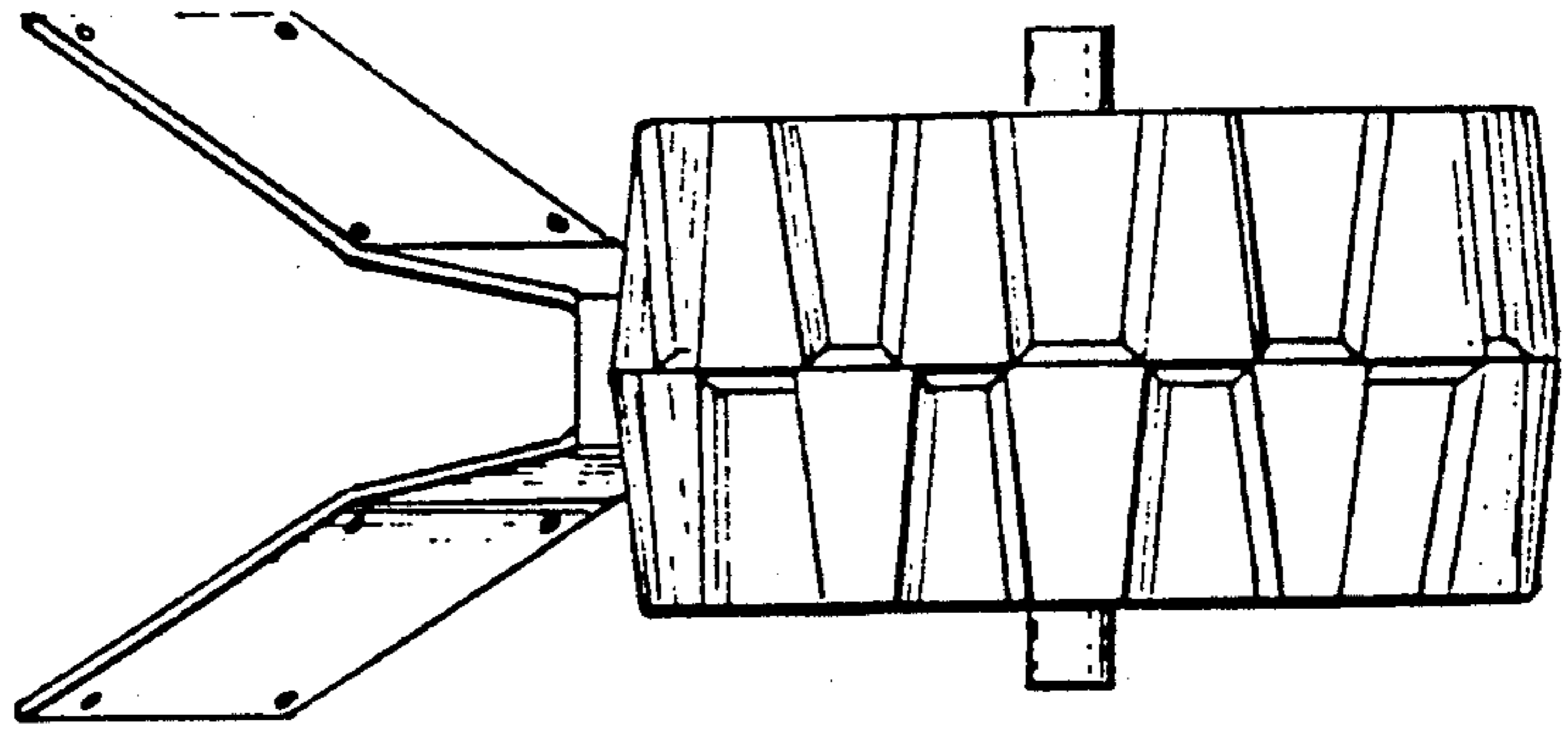
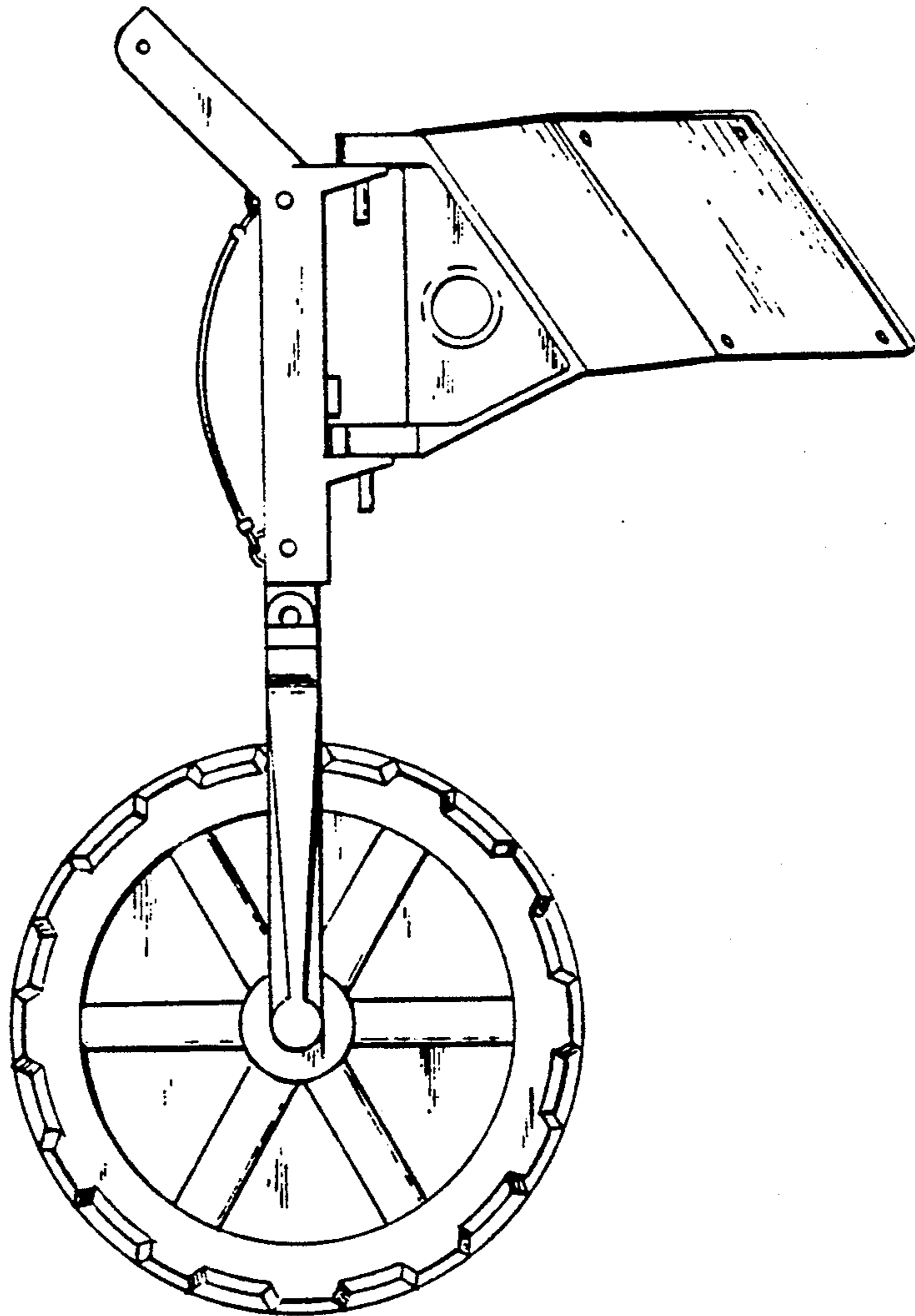

FIG. 8



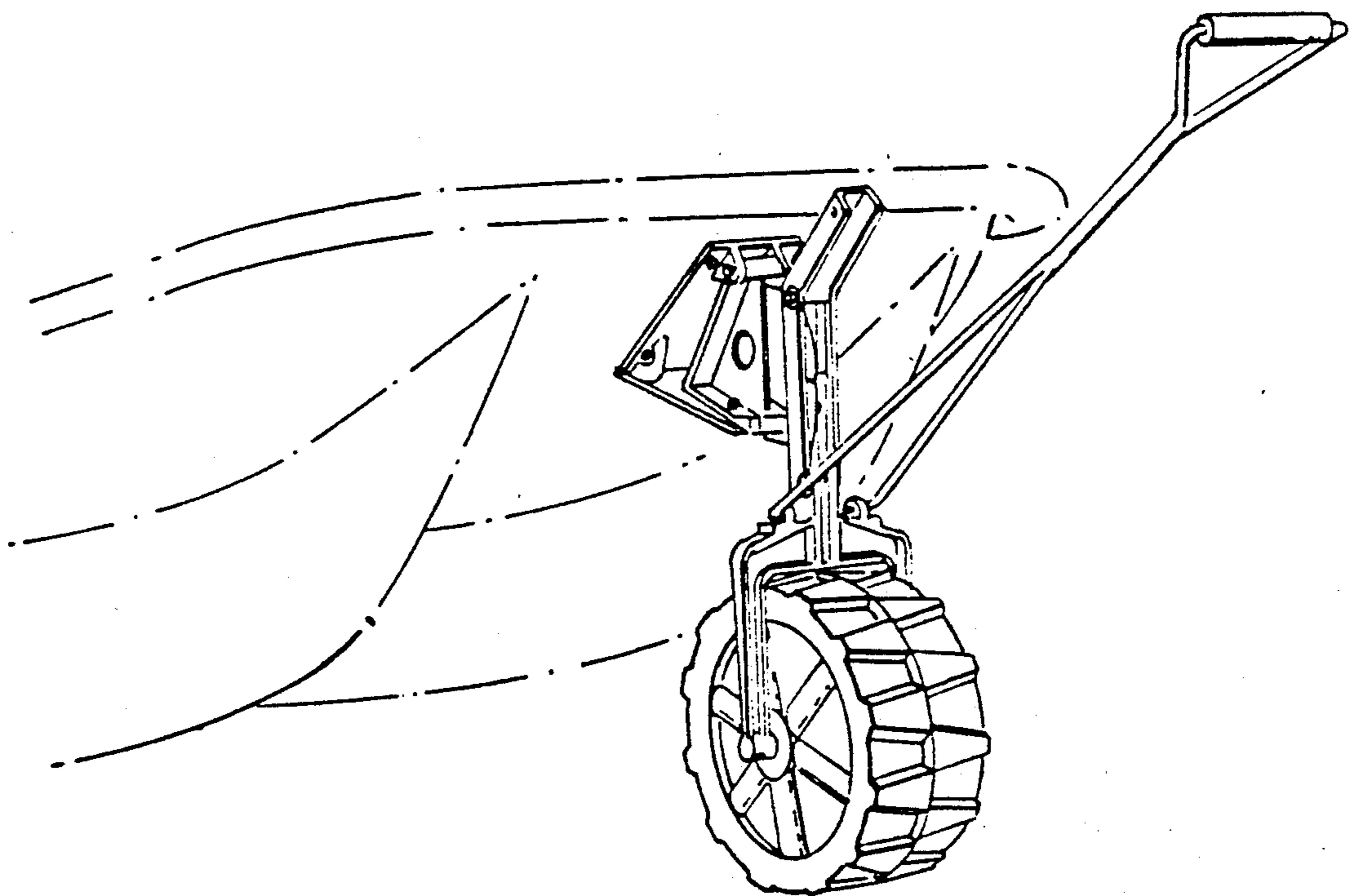

FIG. 9

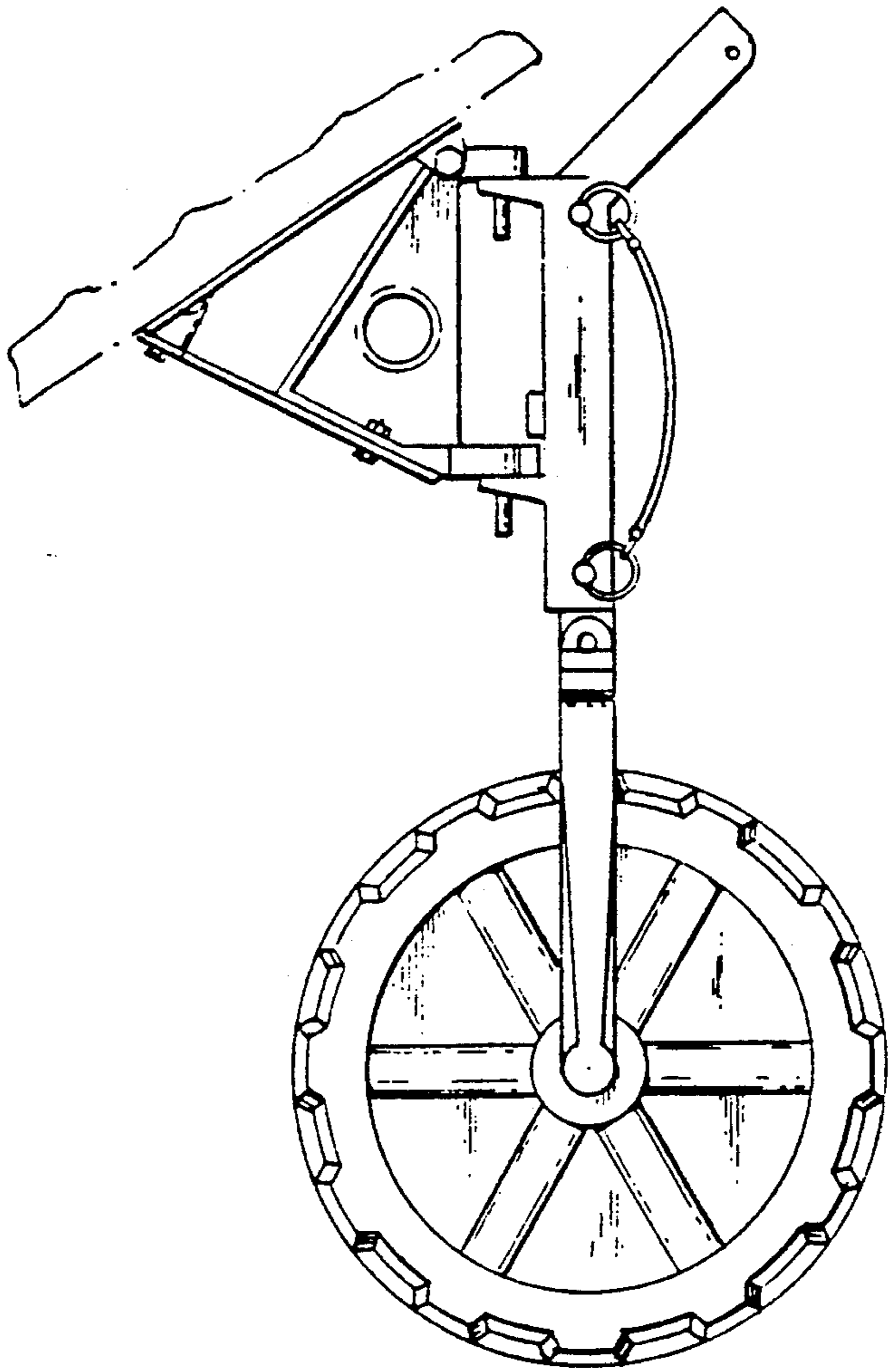
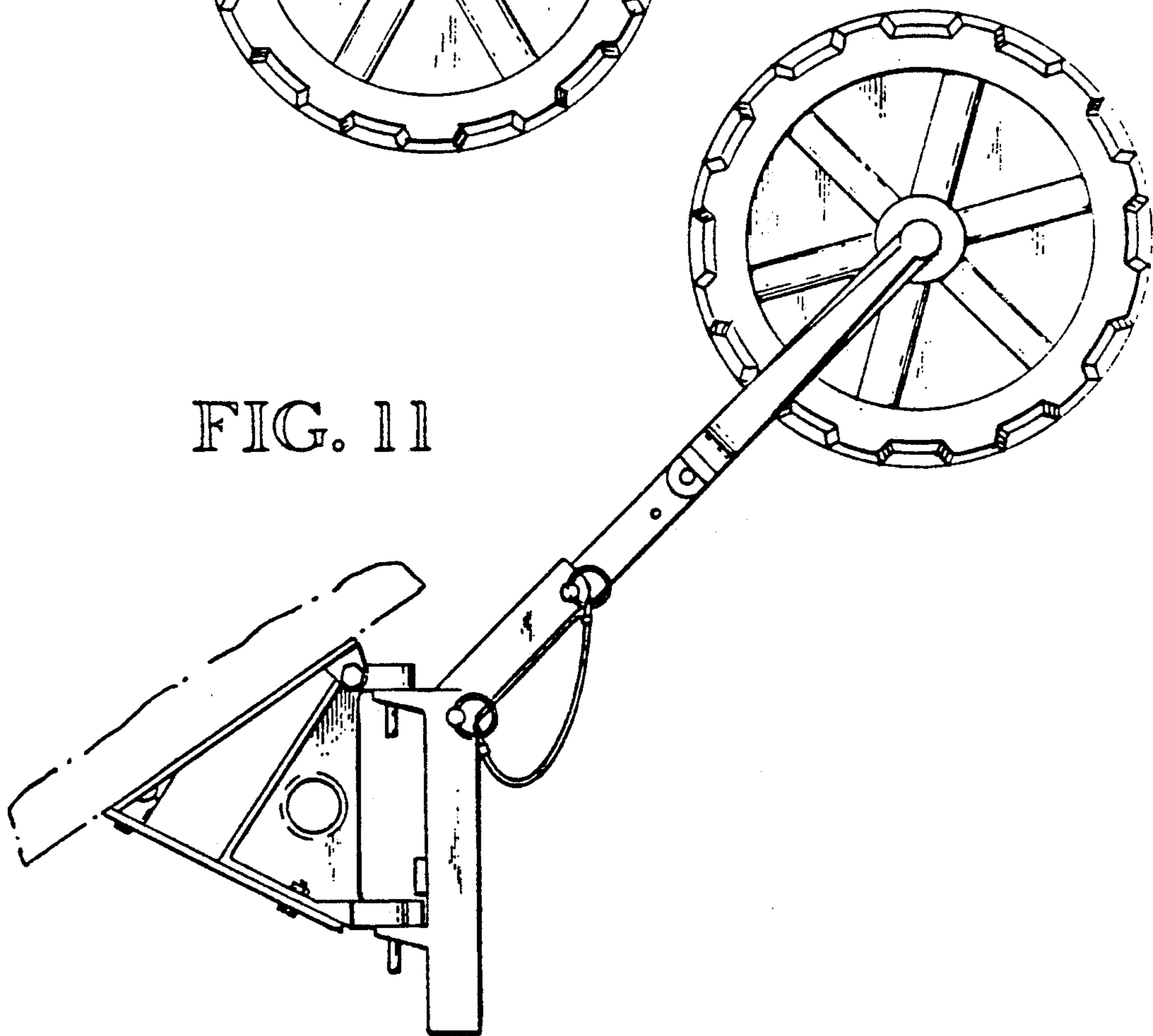

FIG. 10

FIG. 11



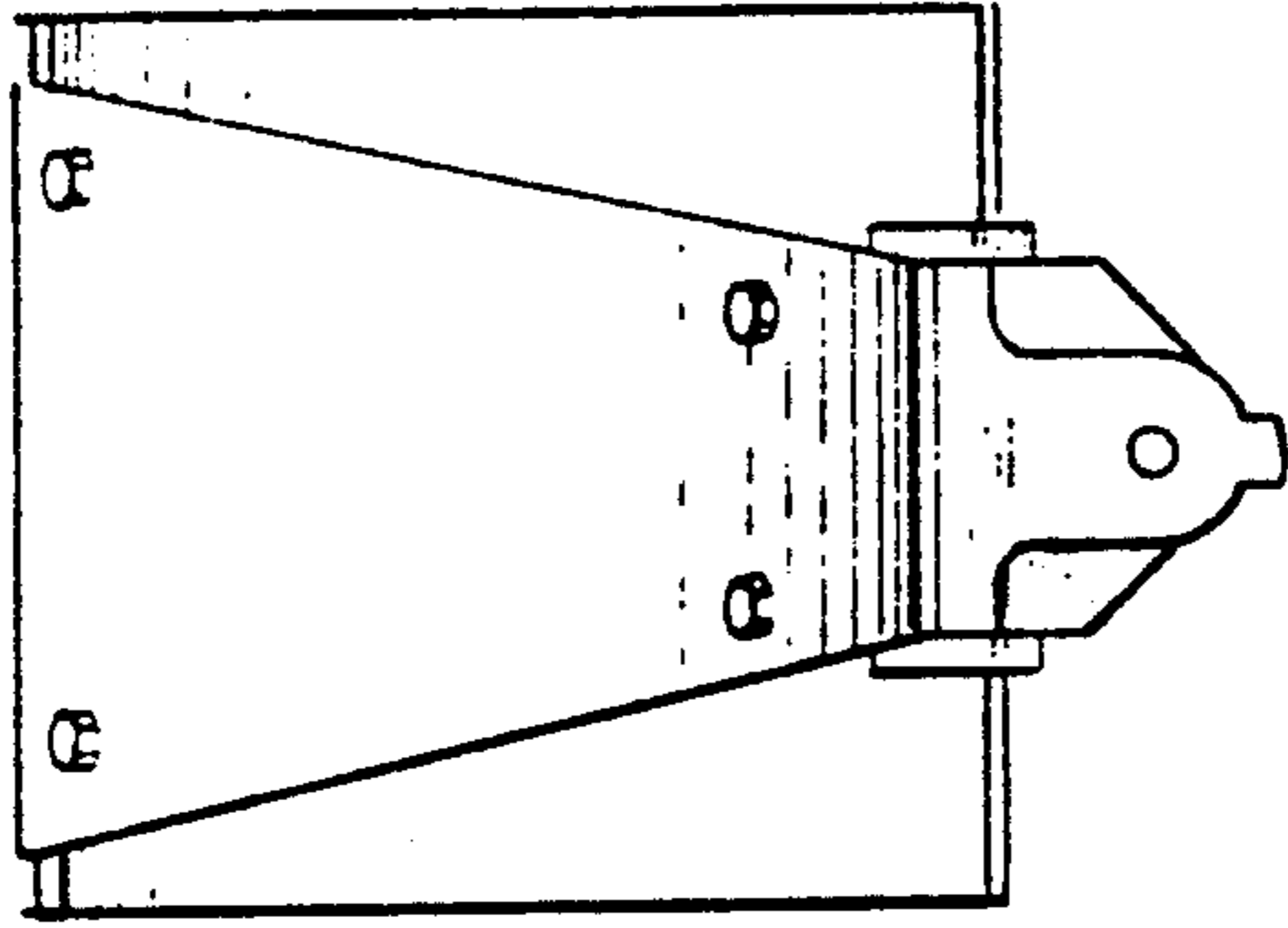

FIG. 12

FIG. 13

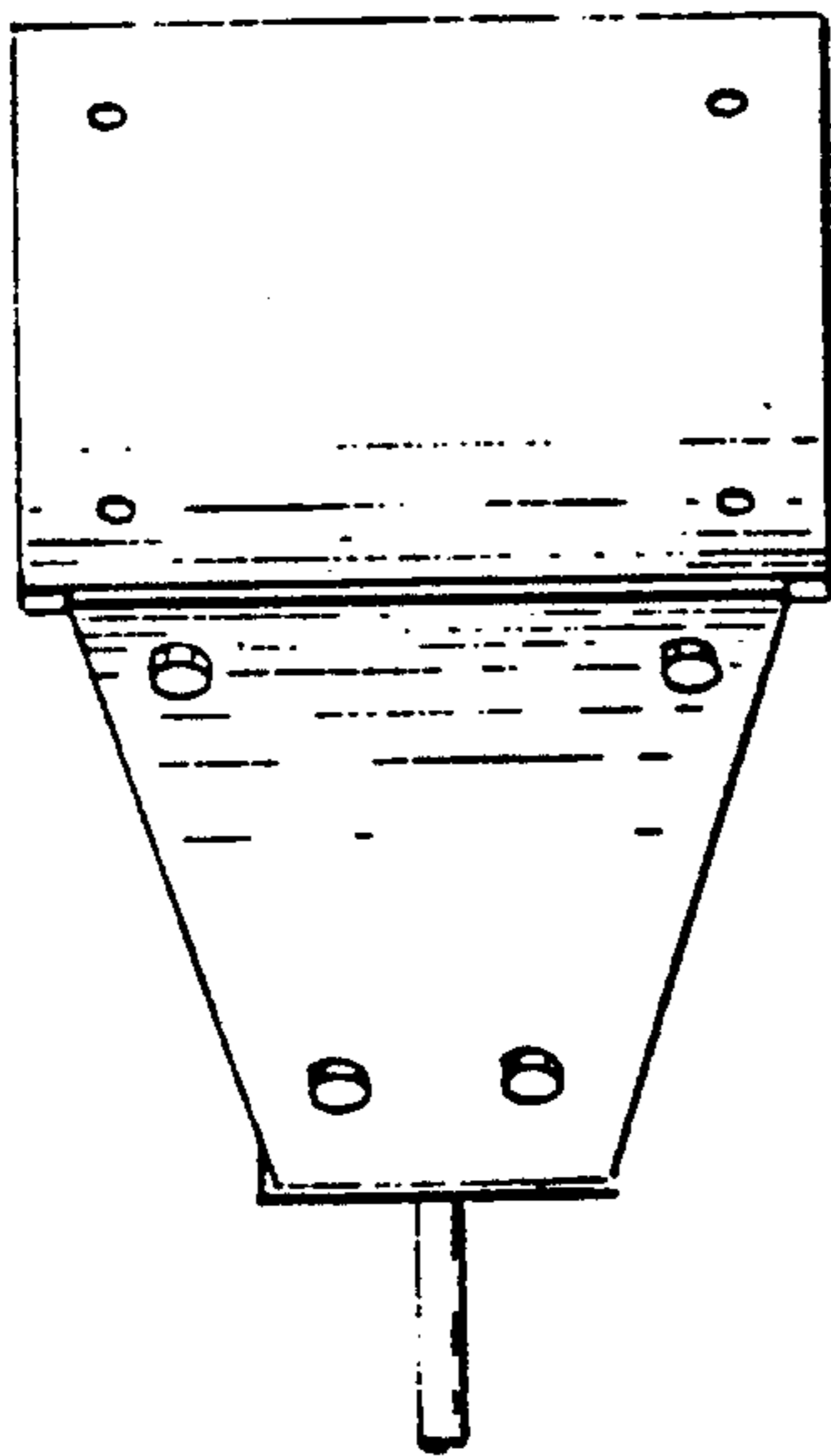
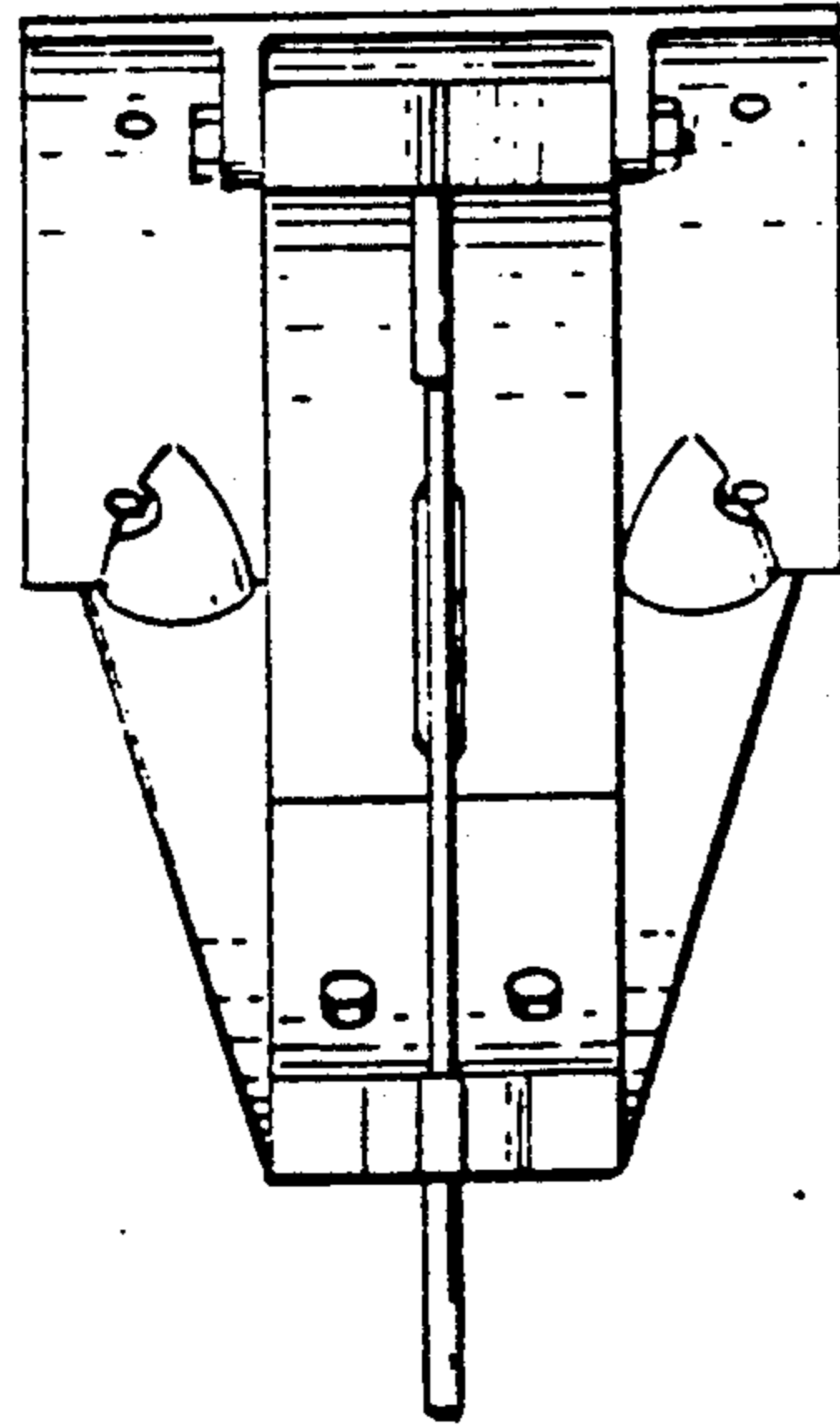

FIG. 14