

[54] DUAL MODE AIRCRAFT

[75] Inventor: Cecil W. Haga, Arlington, Tex.

[73] Assignee: Ishida Foundation, Nagoya, Japan

[**] Term: 14 Years

[21] Appl. No.: 282,346

[22] Filed: Dec. 9, 1988

[52] U.S. Cl. D12/344; D21/87

[58] Field of Search D21/82-91;
D12/319, 325, 344; 446/36, 37, 56, 57, 59

[56] References Cited

U.S. PATENT DOCUMENTS

D. 286,871	11/1986	Bunyard	D12/344
D. 292,393	10/1987	Rutan	D12/344
D. 293,430	12/1987	Koutsoupidis	D12/344
1,731,757	10/1929	Tubbe	D21/90
2,354,392	7/1944	McCoy	D21/90

Primary Examiner—Charles A. Rademaker

Attorney, Agent, or Firm—Sughrue, Mion, Zinn,
Macpeak & Seas

[57] CLAIM

The ornamental design for a dual mode aircraft, as shown and described.

DESCRIPTION

FIG. 1 is a front, top and right side perspective view of a dual mode aircraft showing my new design;
 FIG. 2 is a front elevational view thereof;
 FIG. 3 is a rear elevational view thereof;
 FIG. 4 is a top plan view thereof;
 FIG. 5 is a bottom plan view thereof;
 FIG. 6 is a right side elevational view thereof;
 FIG. 7 is a left side elevational view thereof;
 FIG. 8 is a front, top and right side perspective view thereof with the wing thereof rotated to a vertical position; and
 FIG. 9 is a front, top and right side perspective view of a modified embodiment of the design shown in FIGS. 1 through 8.

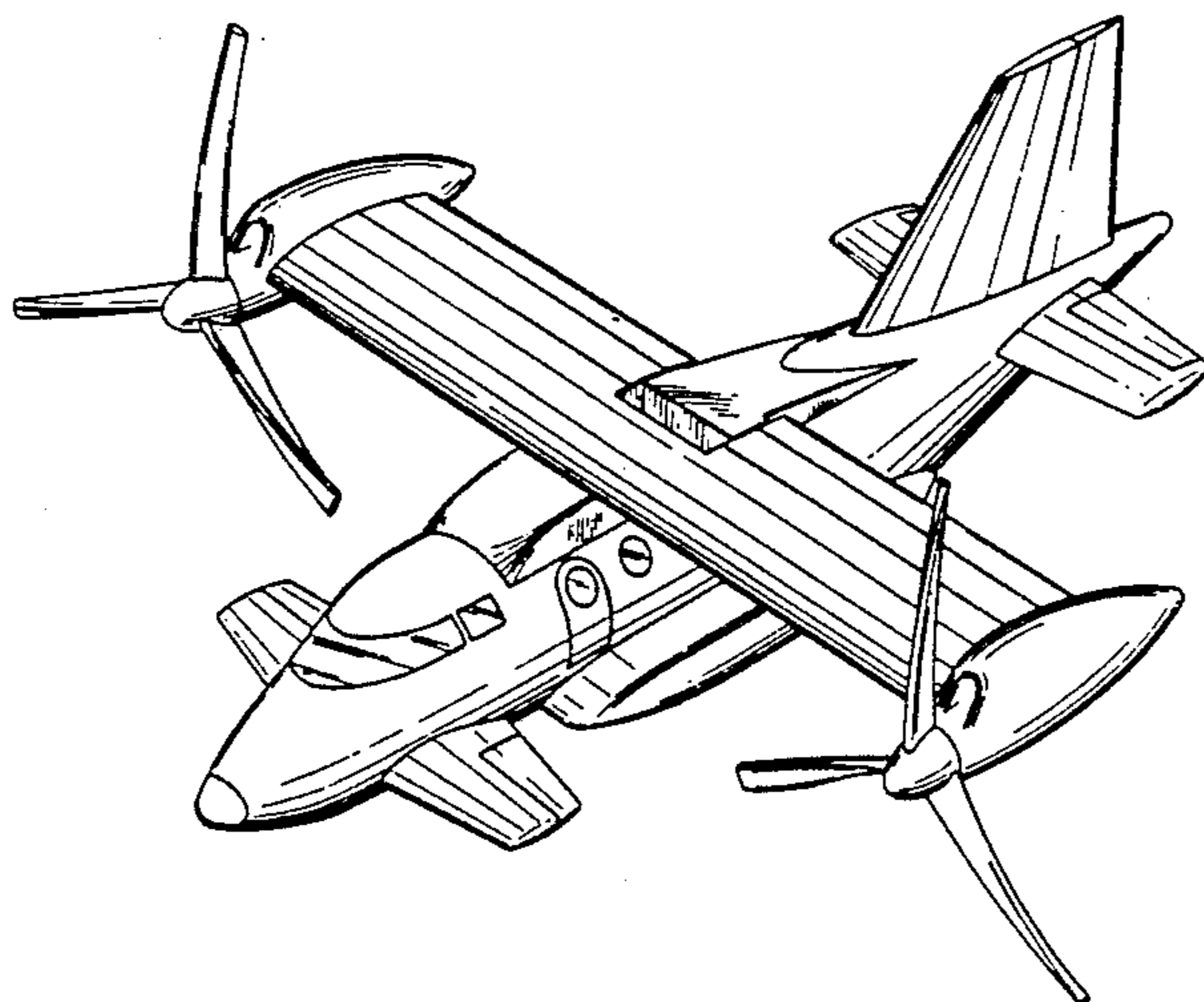
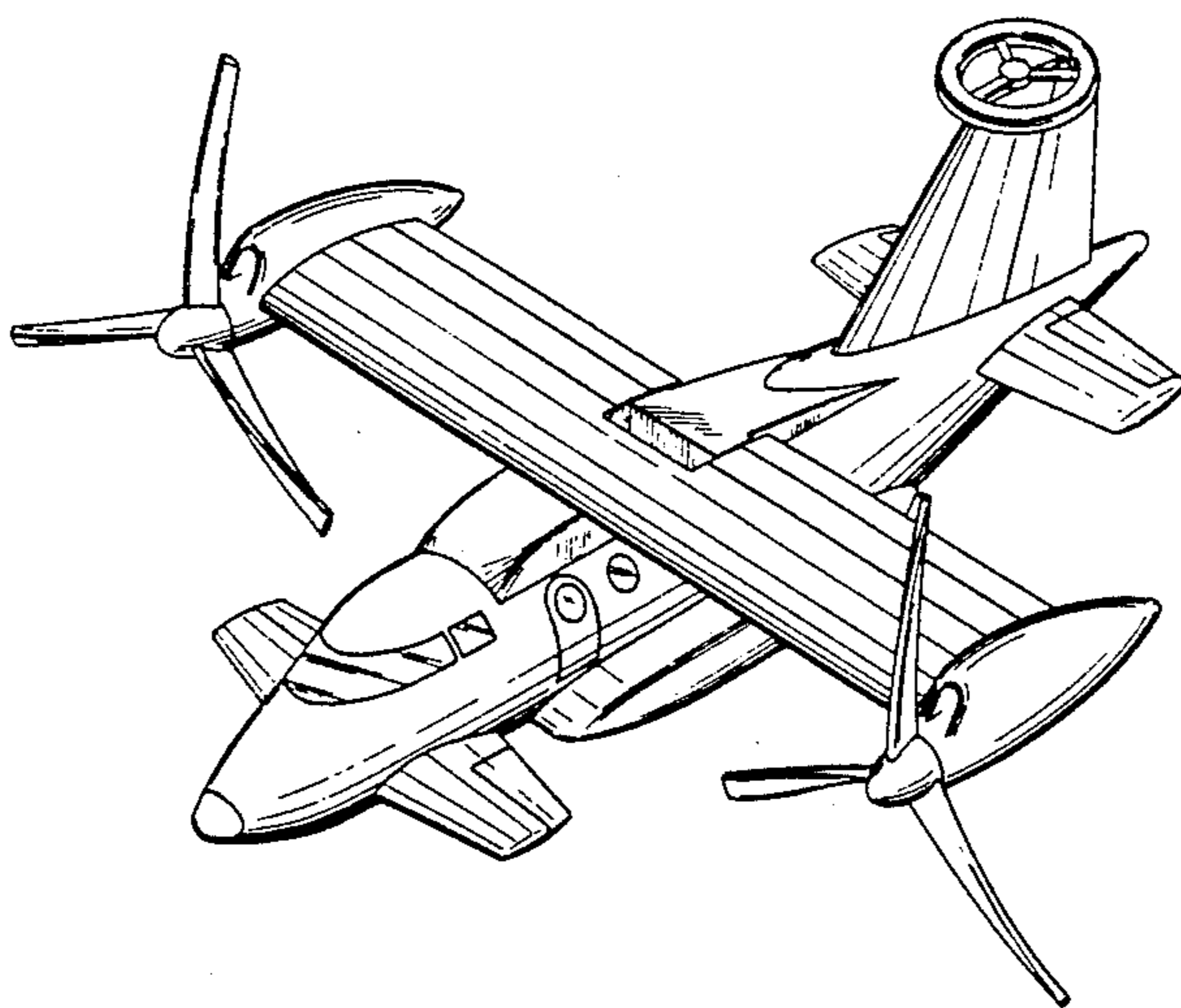

FIG. 1

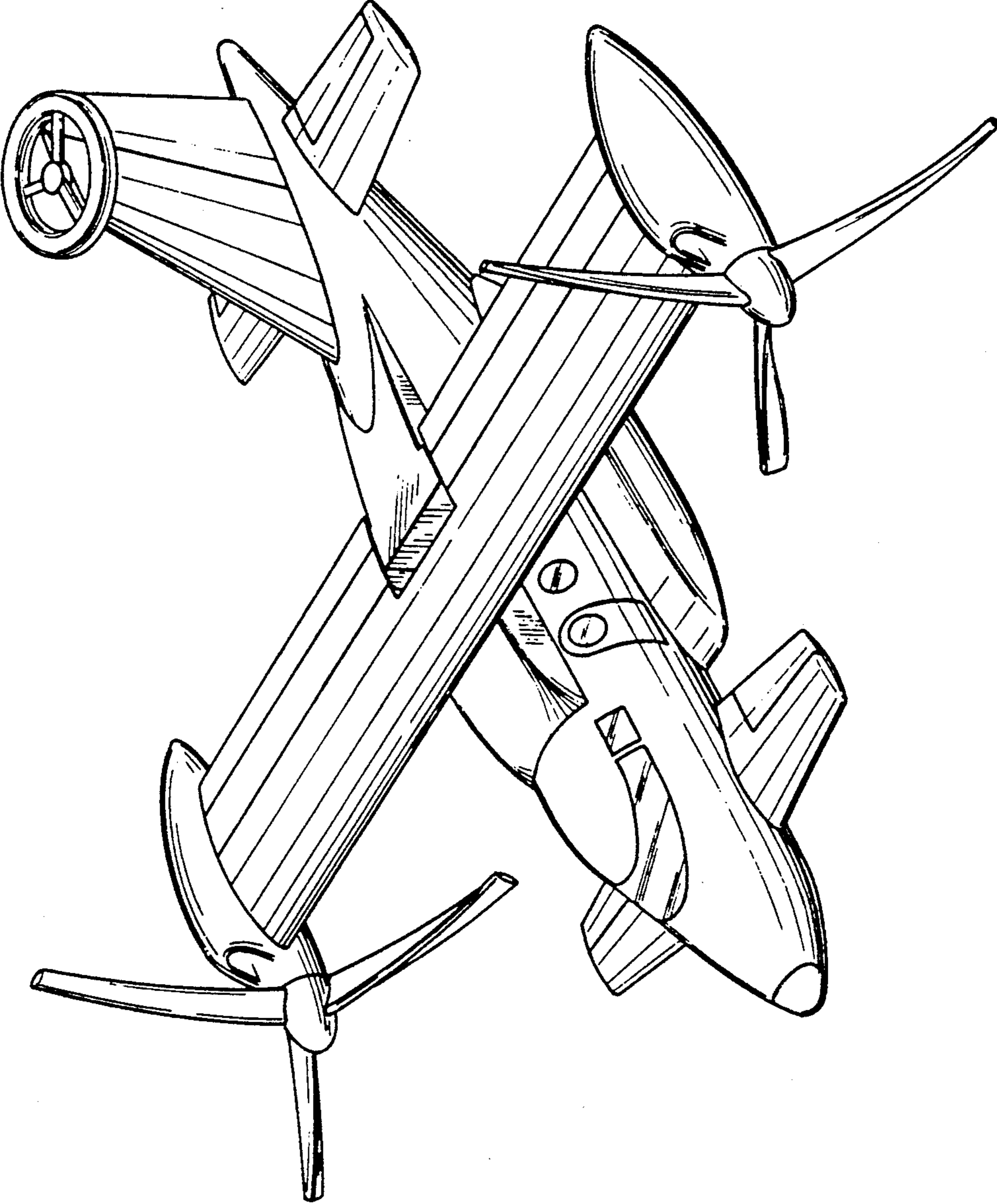

FIG. 2

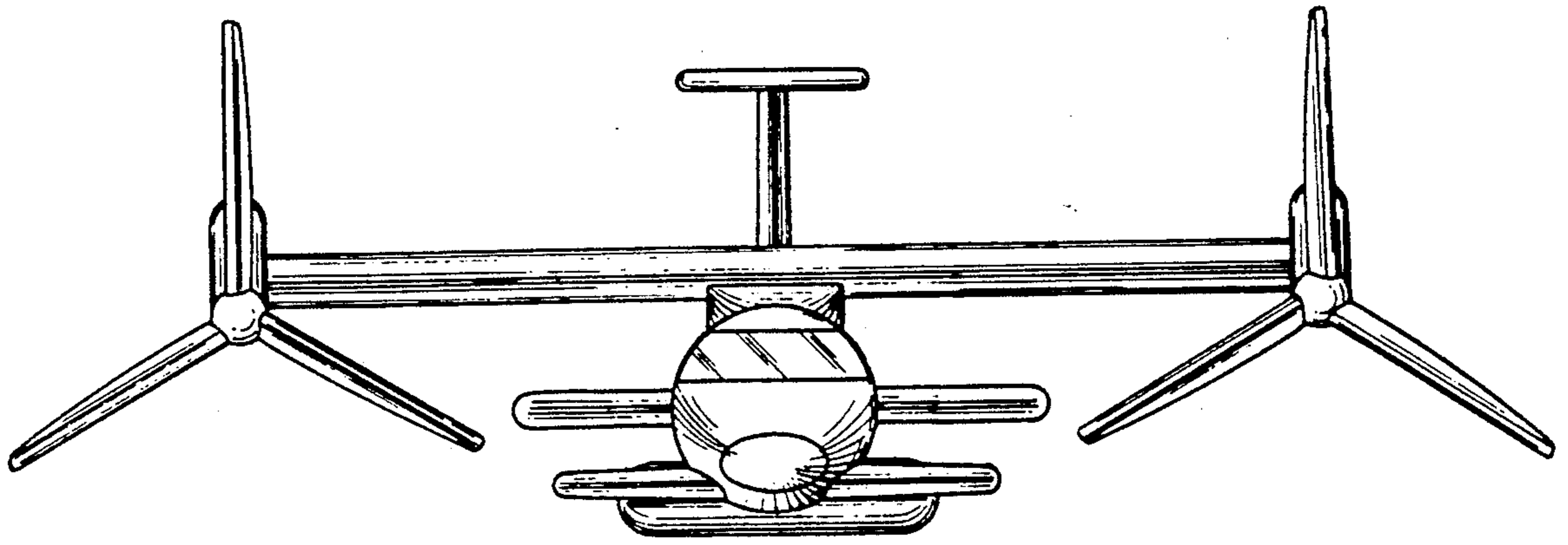

FIG. 3

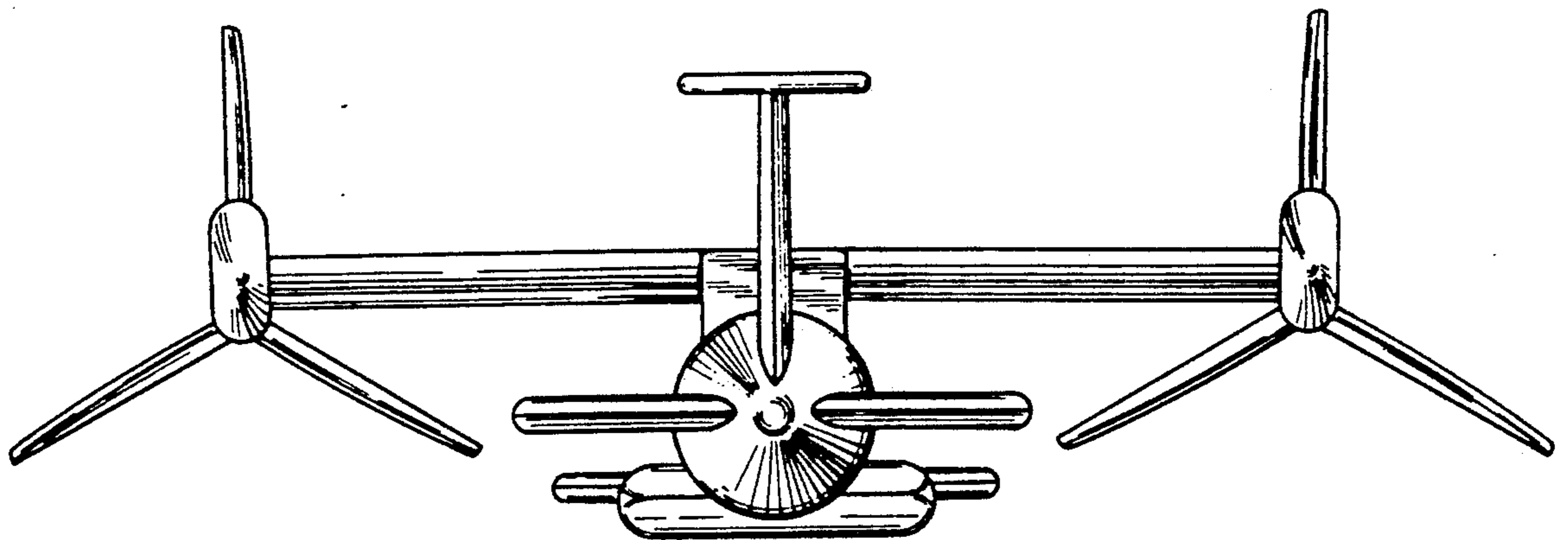

FIG. 4

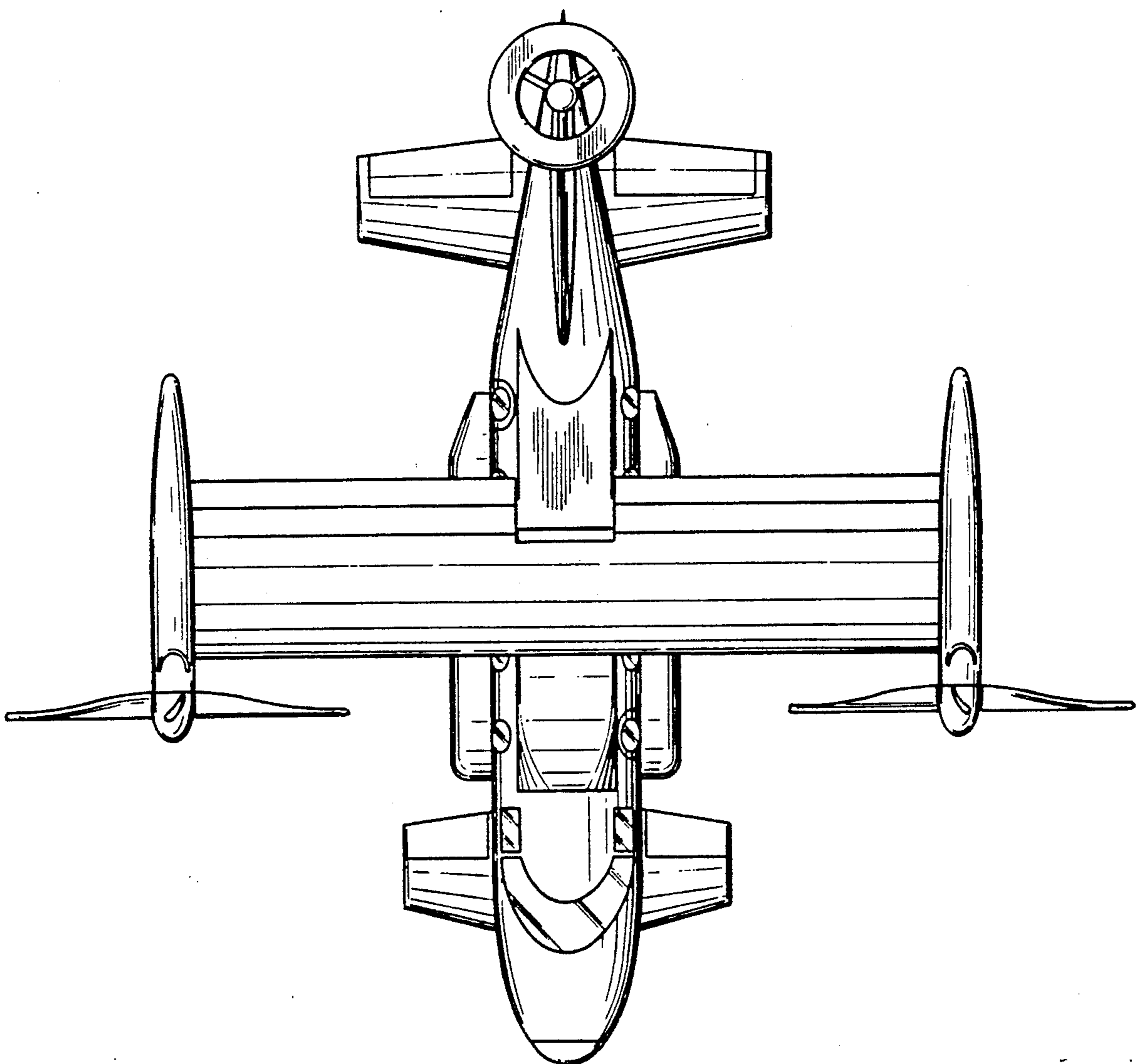
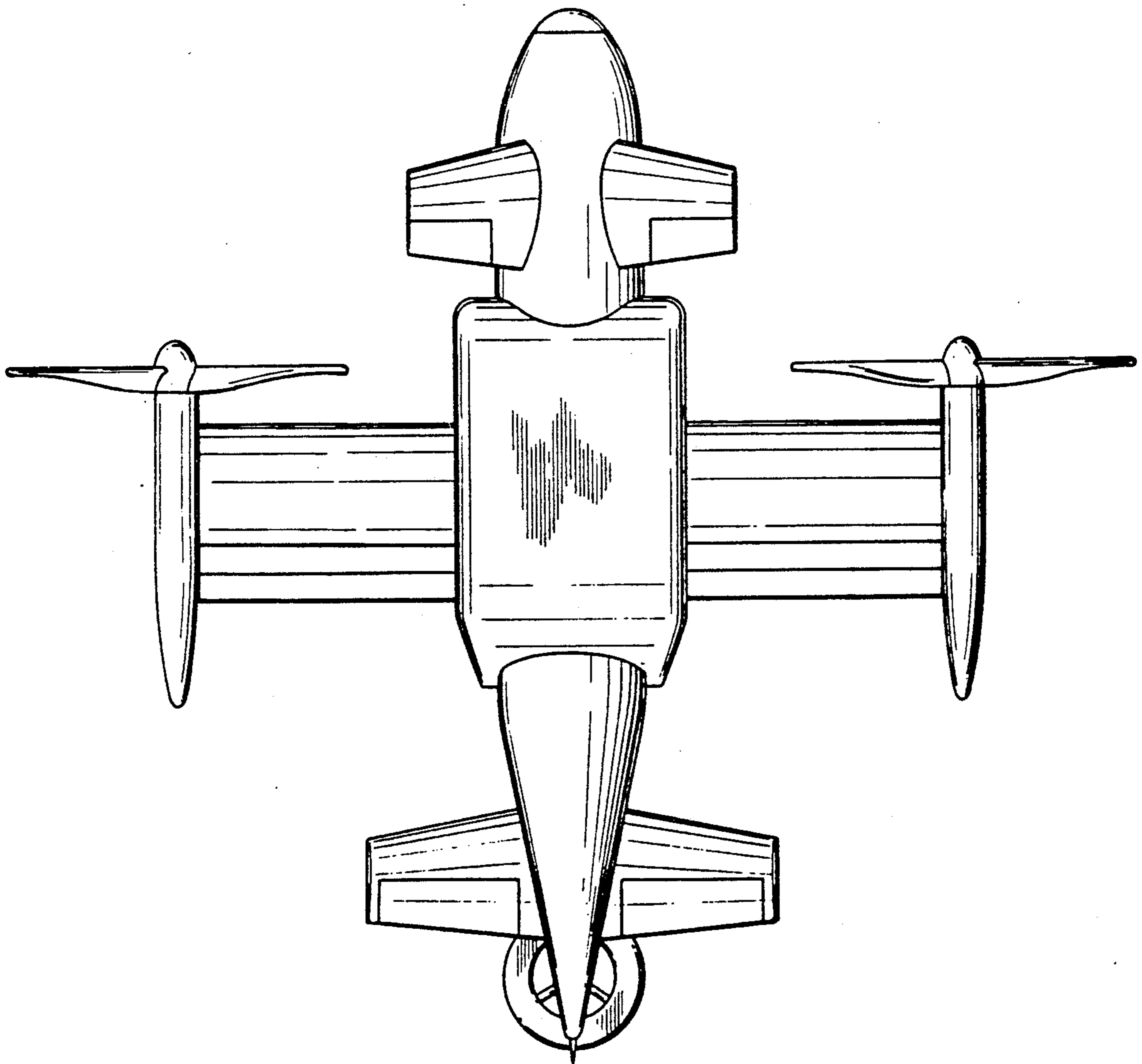

FIG. 5



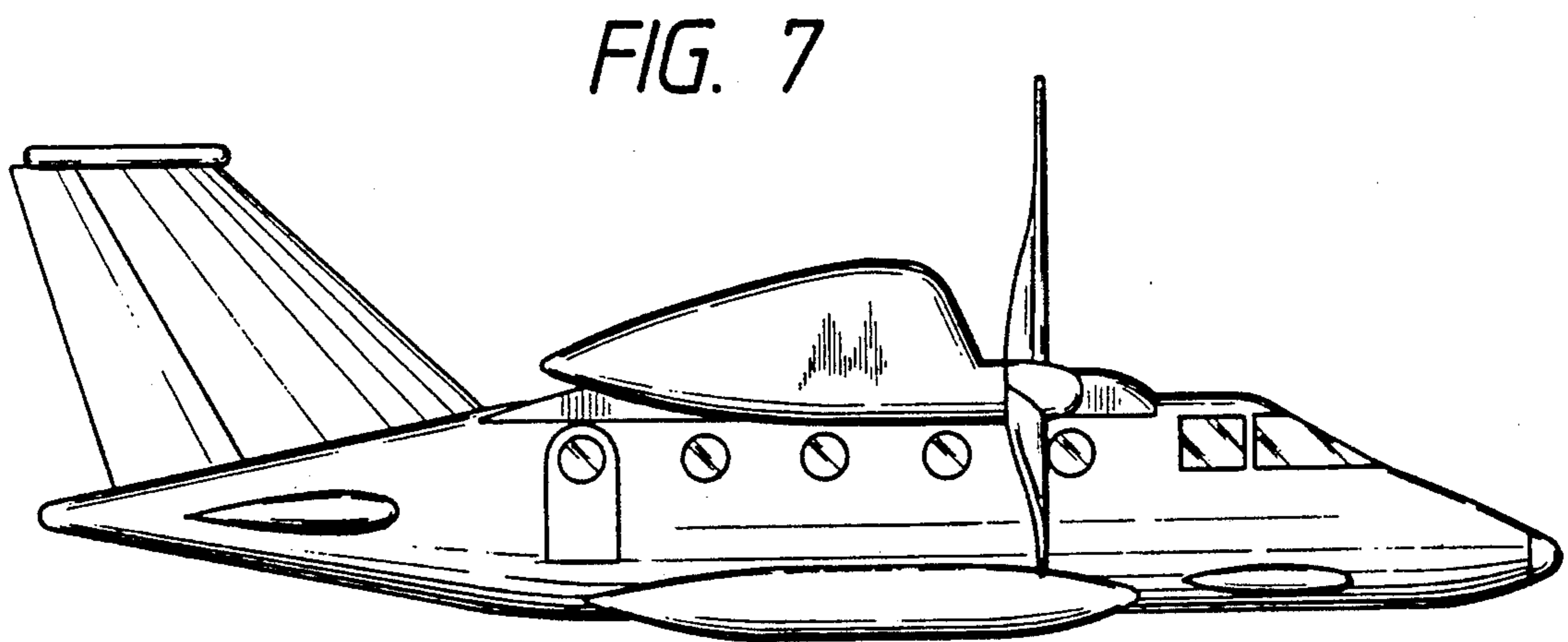
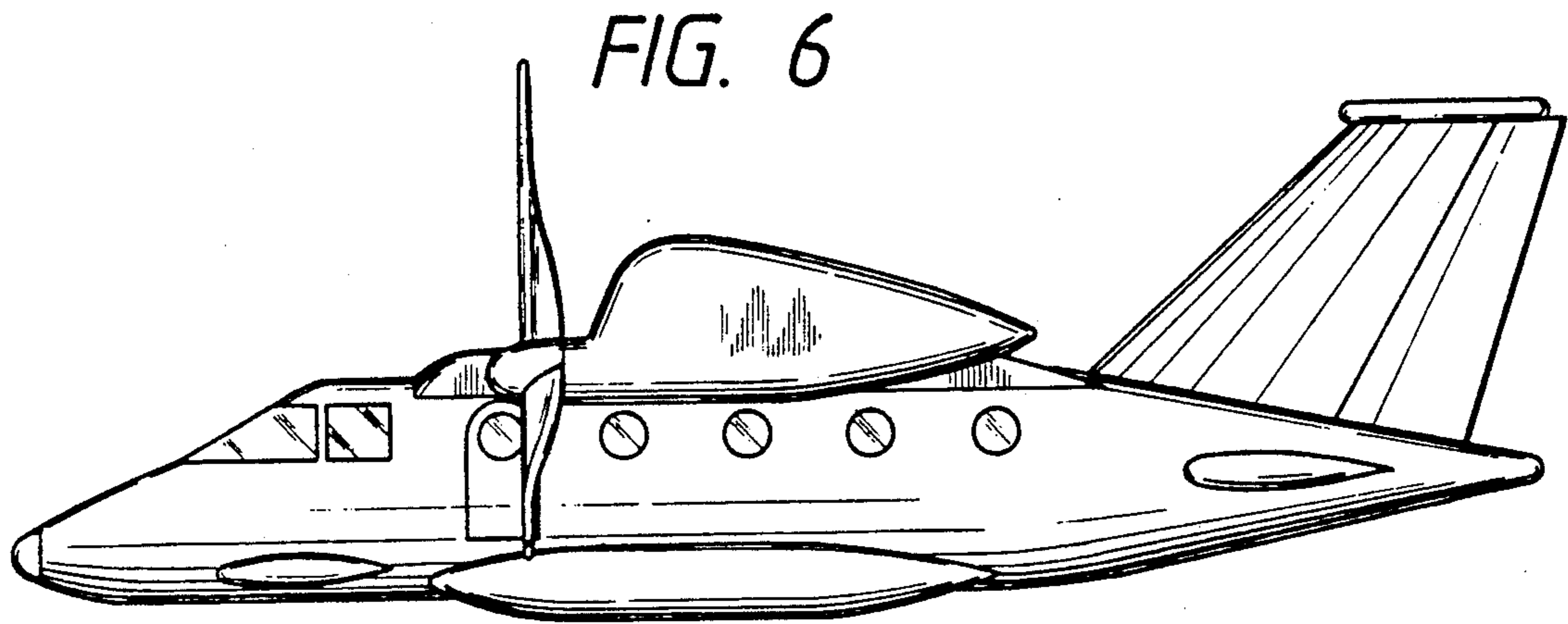

FIG. 8

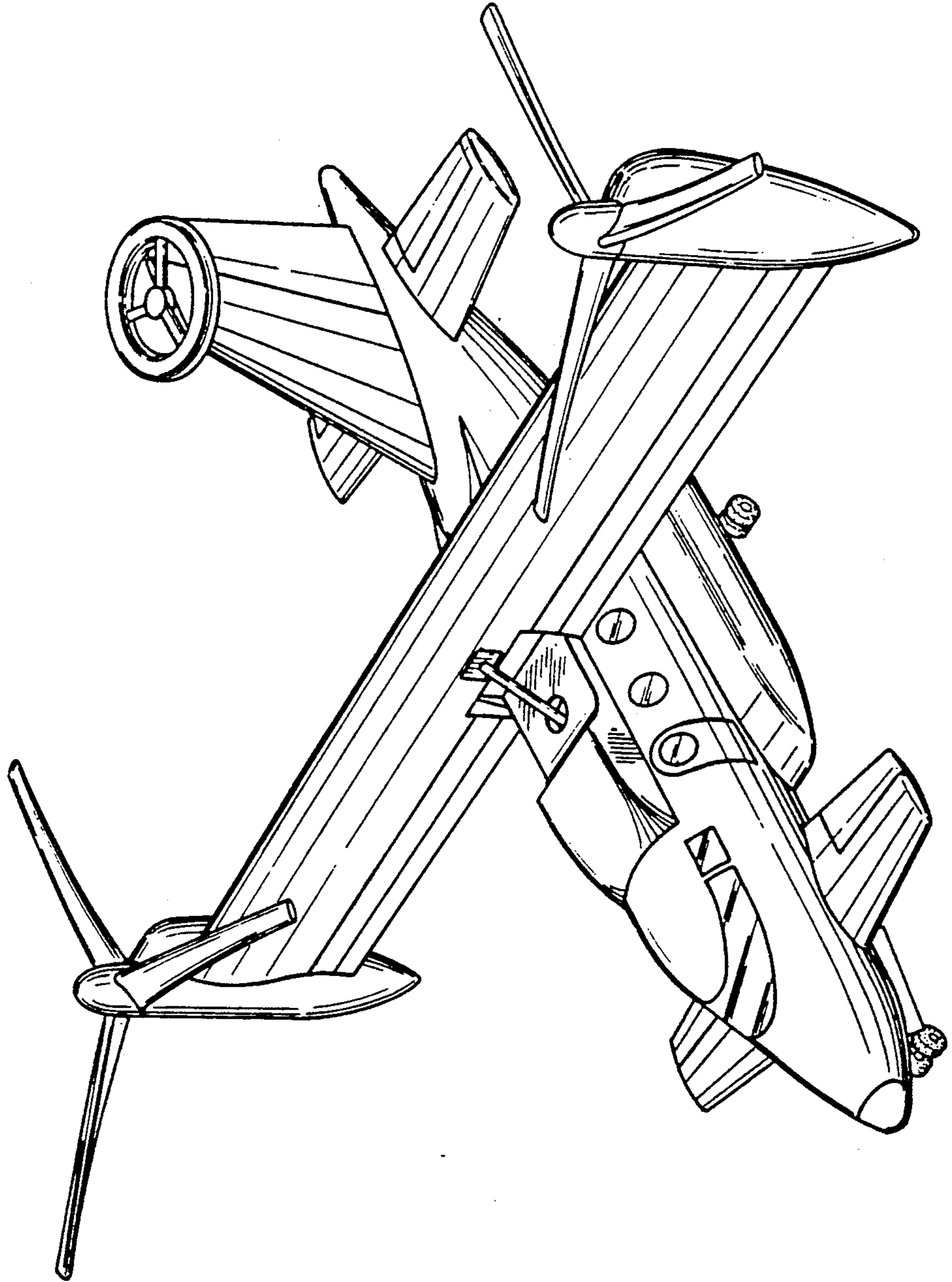

FIG. 9

