

[54] RECESS SIZE DETERMINING GAUGE

[76] Inventor: Robert F. Jackson, Sr., 2242 Foxwood Dr., Orange Park, Fla. 32073

[**] Term: 14 Years

[21] Appl. No.: 259,624

[22] Filed: Oct. 19, 1988

[52] U.S. Cl. D10/64

[58] Field of Search D10/61, 64; 33/501.08, 33/501.09, 501.1, 501.2, 501.3, 501.4, 501.45, 501.5, 199, 201, 548, 545, 550, 551, 552, 562, 563, 564, 565, 566, 567, 568, 569, 570; 71/103, 106, 118, 119, 120, 138, 164, 165, 167, 168, 900; D8/805; 81/439, 440, 469

[56] References Cited

U.S. PATENT DOCUMENTS

D. 120,351	5/1940	Monahan	D10/64
D. 131,640	3/1942	Hollingshead	D10/64
466,044	12/1891	Jacobs	D10/64 X
524,589	8/1894	Gruebel	D10/64
804,067	11/1905	Stowe	D10/64
867,011	9/1907	Bromley	D10/64
992,873	5/1911	Higgins	D10/64 X
1,369,829	3/1921	Minges	D10/64 X
1,787,424	1/1931	Altenbach	D10/64 X
1,810,166	6/1931	Gallimore	33/501.45

Primary Examiner—Nelson C. Holtje
 Assistant Examiner—Antoine D. Davis
 Attorney, Agent, or Firm—Arthur G. Yeager

[57] CLAIM

The ornamental design for recess size determining gauge, as shown and described.

DESCRIPTION

FIG. 1 is a top plan view of a recess size determining gauge showing my new design;
 FIG. 2 is a left side elevational view;
 FIG. 3 is a front elevational view;
 FIG. 4 is a right side elevational view;
 FIG. 5 is a bottom plan view;
 FIG. 6 is a front elevational view in an open position;

FIG. 7 is a top plan view showing of the second embodiment of my new design of FIGS. 1-6;
 FIG. 8 is a left side elevational view;
 FIG. 9 is a front elevational view;
 FIG. 10 is a right side elevational view;
 FIG. 11 is a bottom plan view;
 FIG. 12 is a front elevational view in an open position;
 FIG. 13 is a top plan view of a third embodiment of my new design of FIGS. 1-6;
 FIG. 14 is a left side elevational view;
 FIG. 15 is a front elevational view;
 FIG. 16 is a right side elevational view;
 FIG. 17 is a bottom plan view;
 FIG. 18 is a front elevational view in an open position;
 FIG. 19 is a top plan view of a fourth embodiment of my new design of FIGS. 1-6;
 FIG. 20 is a left side elevational view;
 FIG. 21 is a front elevational view;
 FIG. 22 is a right side elevational view;
 FIG. 23 is a bottom plan view;
 FIG. 24 is a front elevational view in an open position;
 FIG. 25 is a top plan view of a fifth embodiment of my new design of FIGS. 1-6;
 FIG. 26 is a left side elevational view;
 FIG. 27 is a front elevational view;
 FIG. 28 is a right side elevational view;
 FIG. 29 is a bottom plan view;
 FIG. 30 is a front elevational view in an open position;
 FIG. 31 is a top plan view of a sixth embodiment of my new design of FIGS. 1-6;
 FIG. 32 is a left side elevational view;
 FIG. 33 is a front elevational view;
 FIG. 34 is a right side elevational view;
 FIG. 35 is a bottom plan view;
 FIG. 36 is a front elevational view in an open position;
 FIG. 37 is a top plan view of a seventh embodiment of my new design of FIGS. 1-6;
 FIG. 38 is a left side elevational view;
 FIG. 39 is a front elevational view;
 FIG. 40 is a right side elevational view;
 FIG. 41 is a bottom plan view;
 FIG. 42 is a front elevational view in an open position;
 FIG. 43 is a top plan view of an eighth embodiment of my new design of FIGS. 1-6;
 FIG. 44 is a left side elevational view;
 FIG. 45 is a front elevational view;

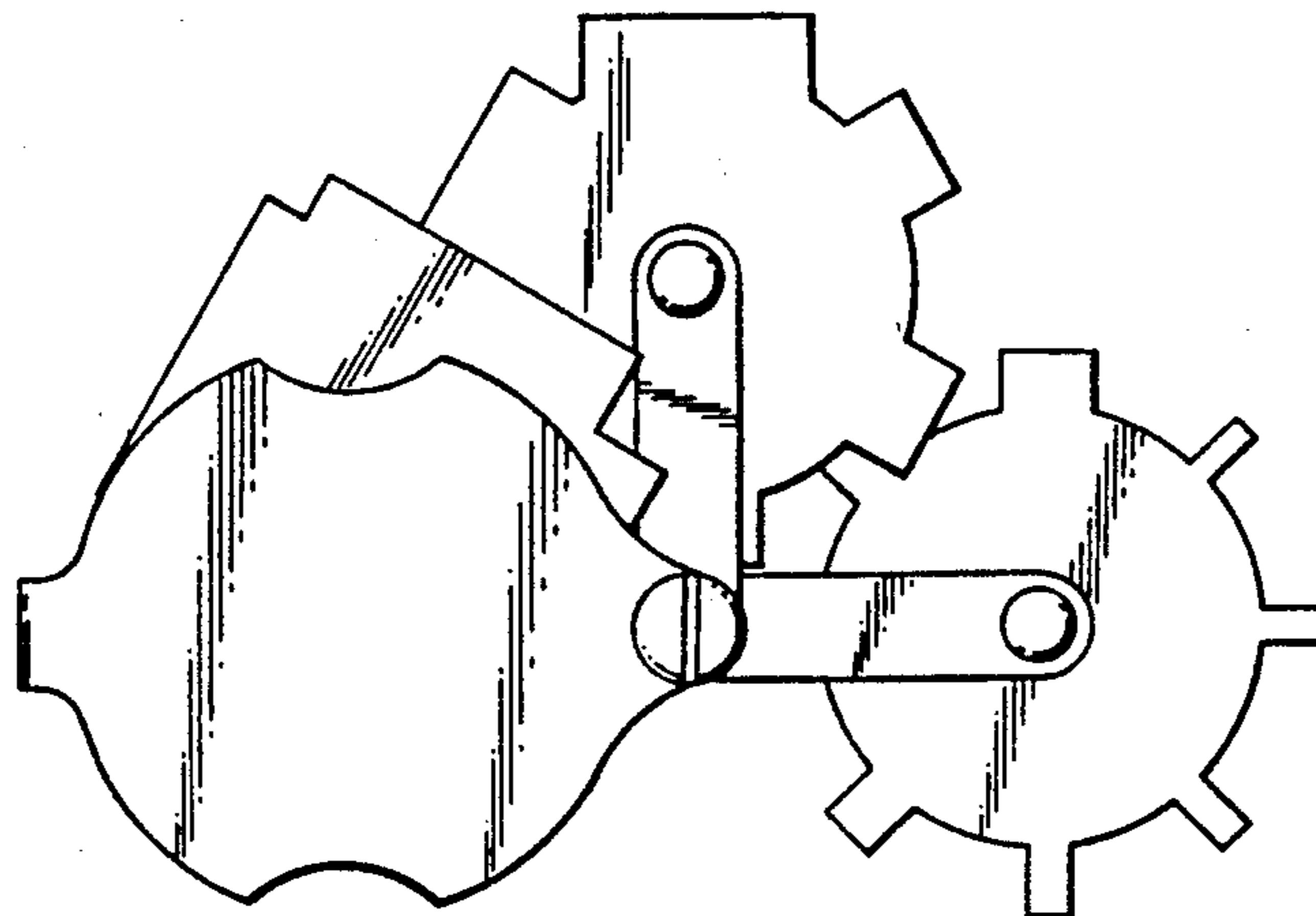

FIG. 46 is a right side elevational view;
FIG. 47 is a bottom plan view;
FIG. 48 is a front elevational view in an open position;
FIG. 49 is a top plan view of a ninth embodiment of my new design of FIGS. 1-6;

FIG. 50 is a left side elevational view;
FIG. 51 is a front elevational view;
FIG. 52 is a right side elevational view;
FIG. 53 is a bottom plan view; and
FIG. 54 is a front elevational view thereof, in an open position.

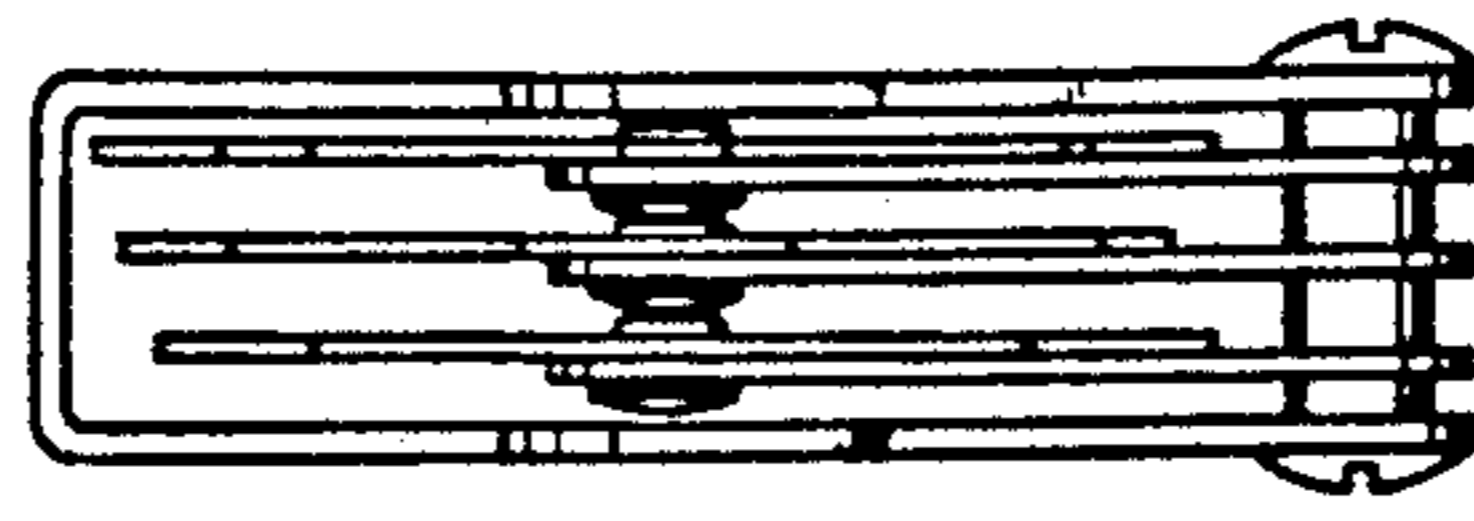

FIG 1

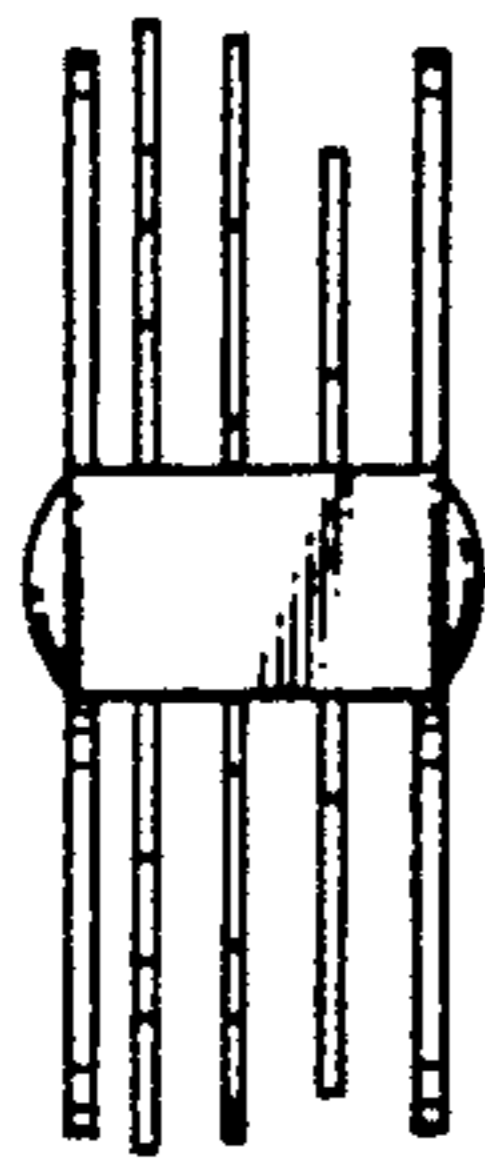

FIG 2

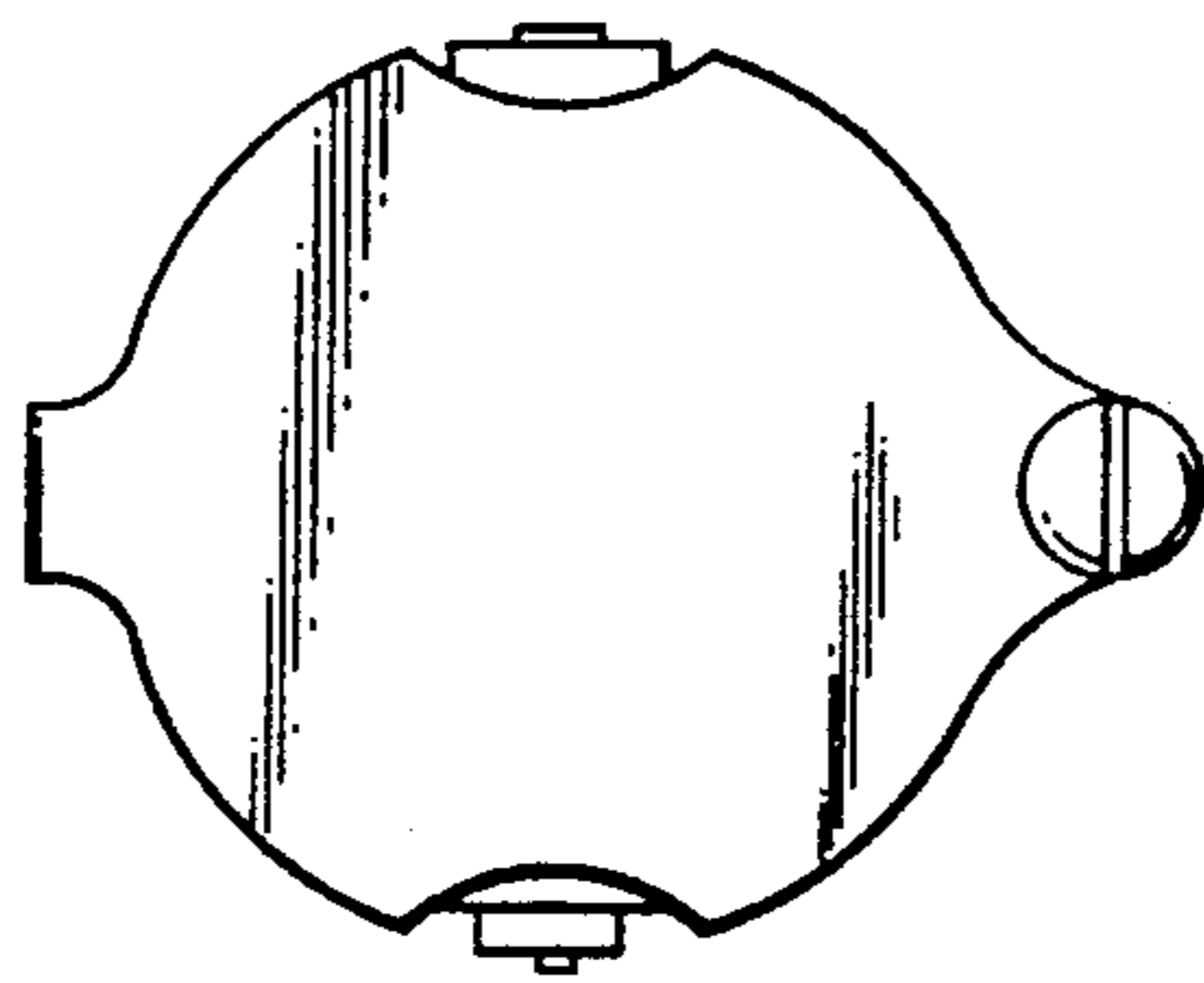

FIG 3

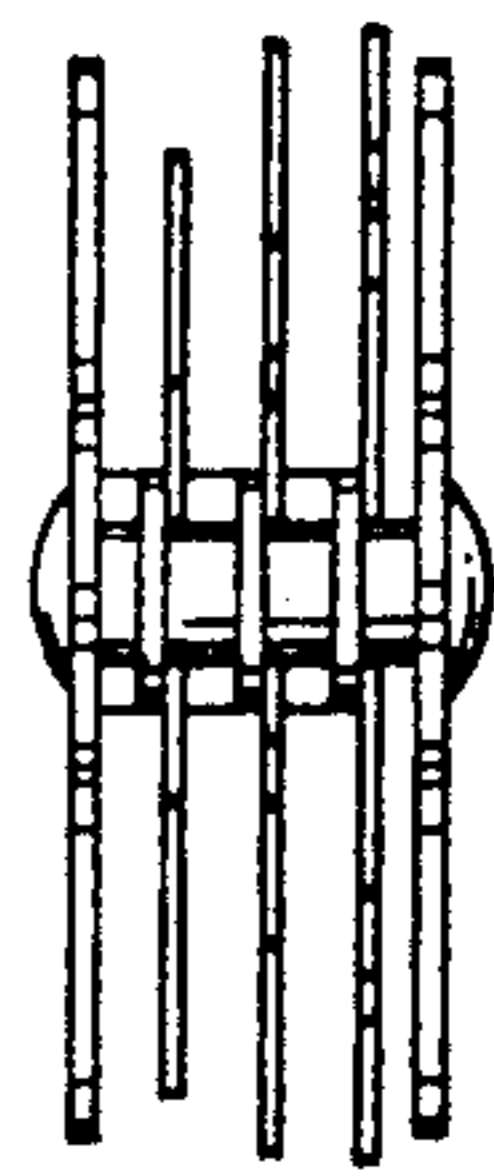

FIG 4

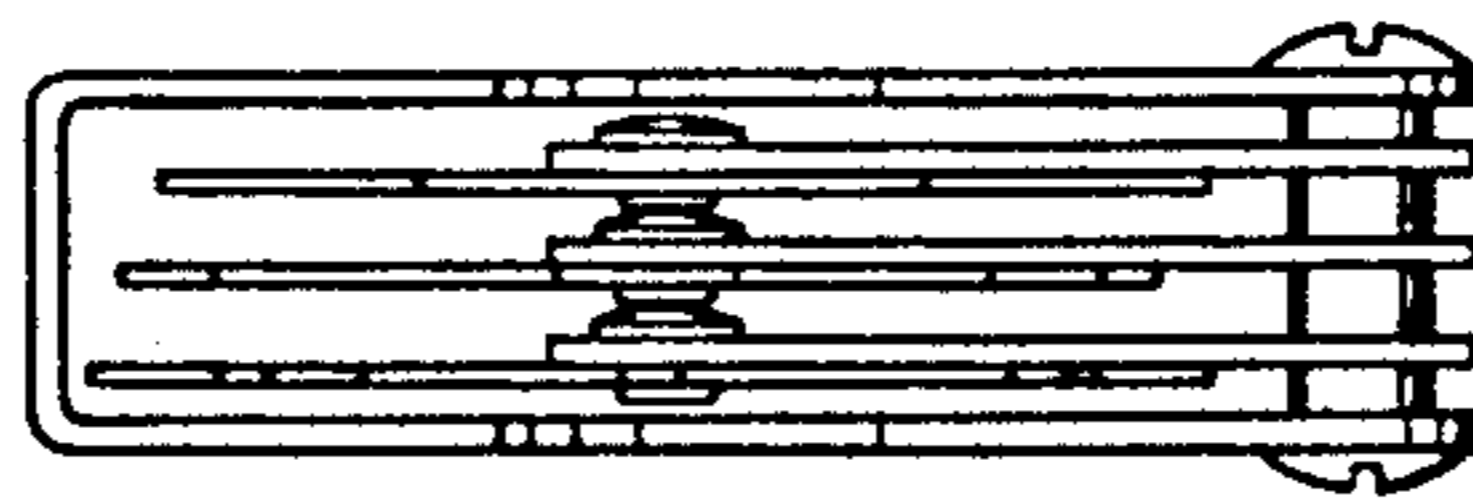

FIG 5

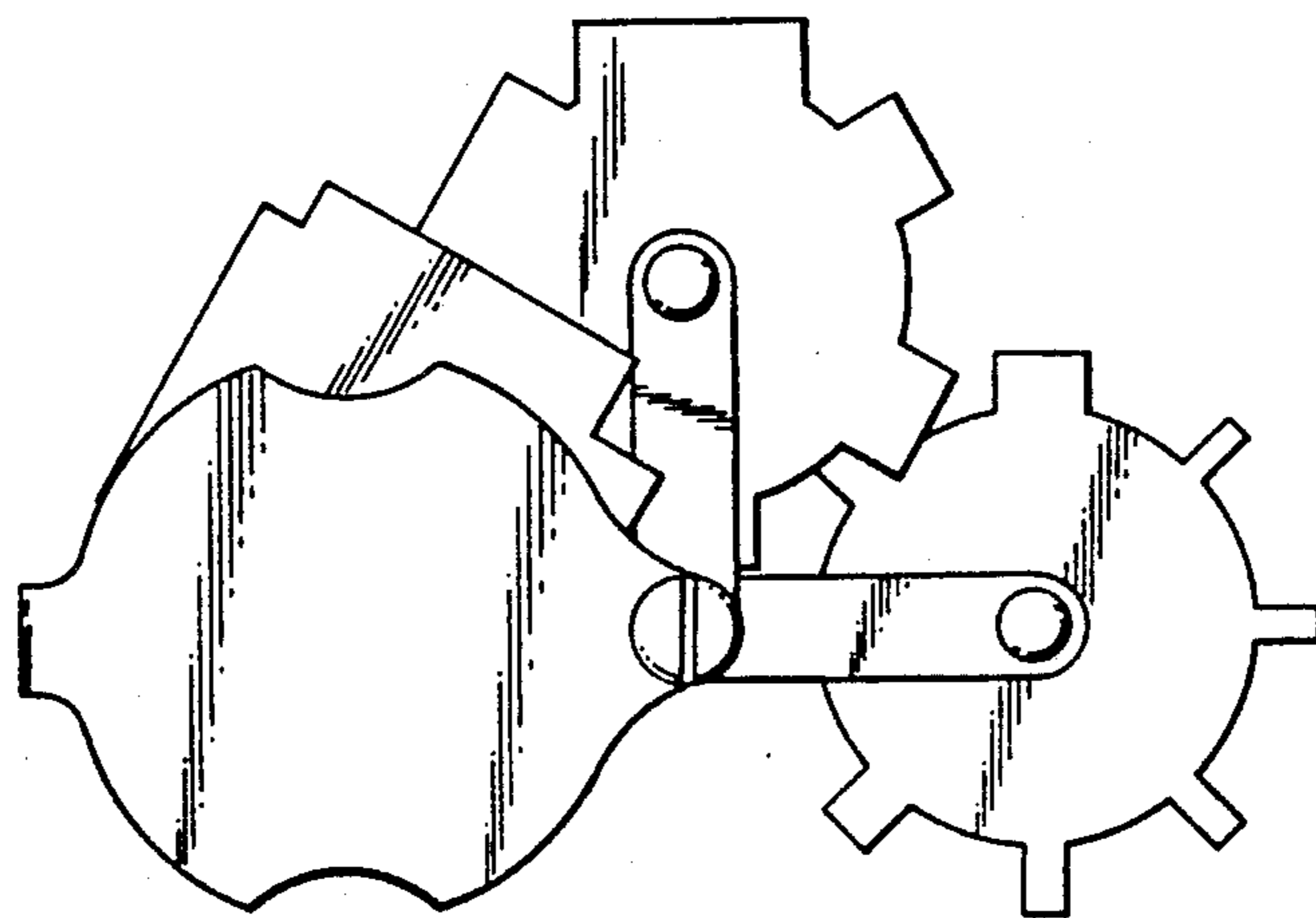

FIG 6

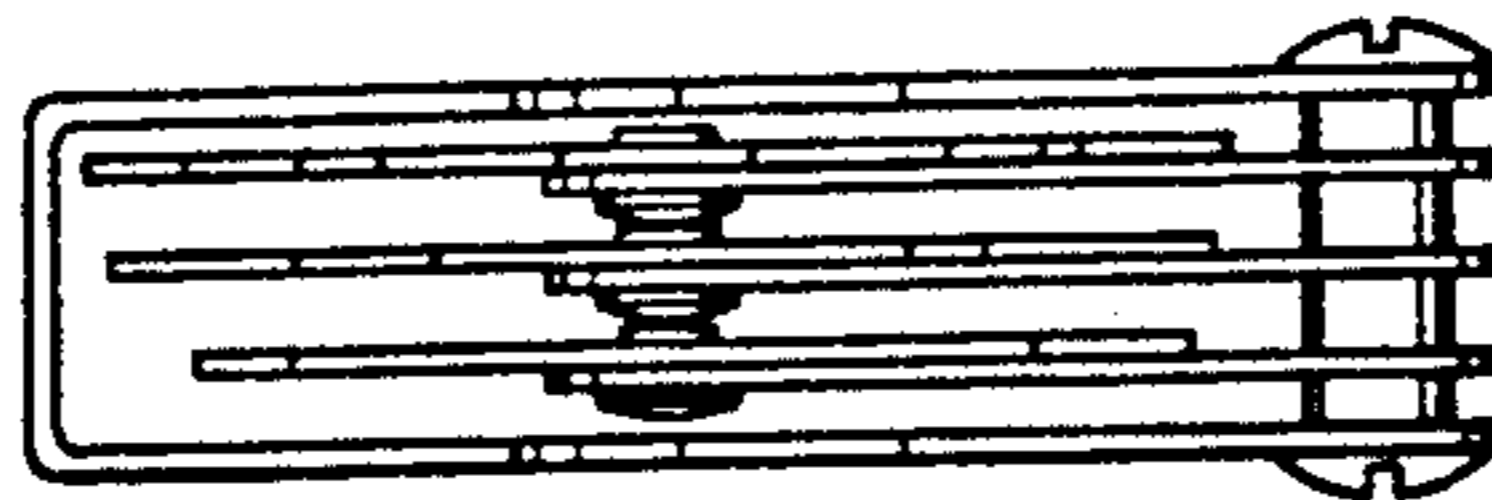

FIG 7

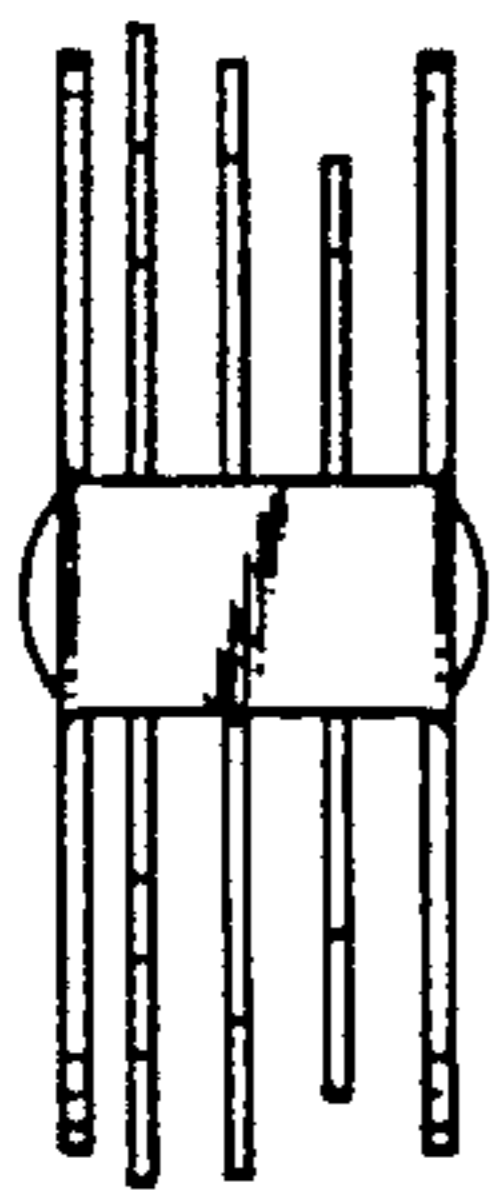

FIG 8

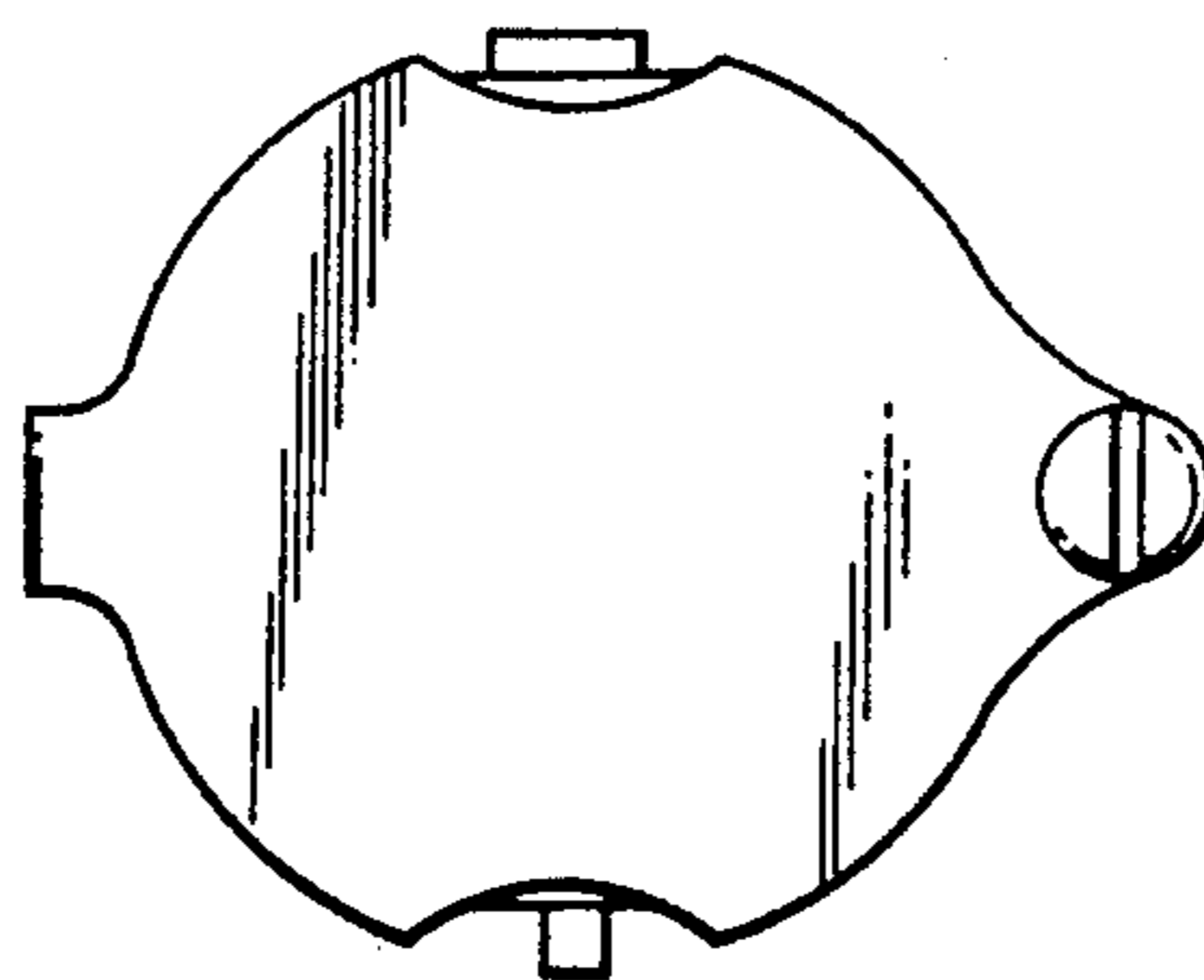

FIG 9

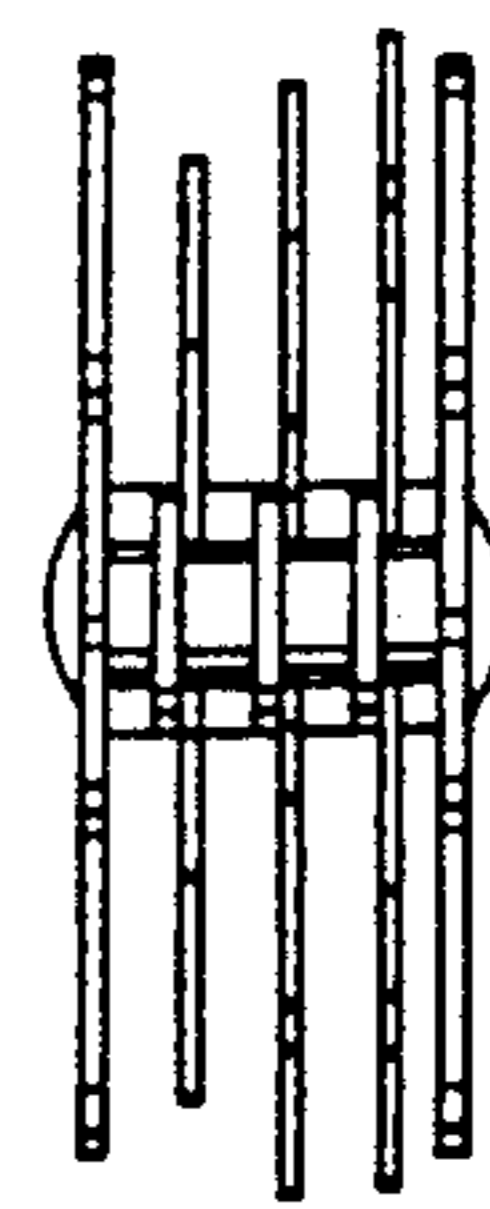

FIG 10

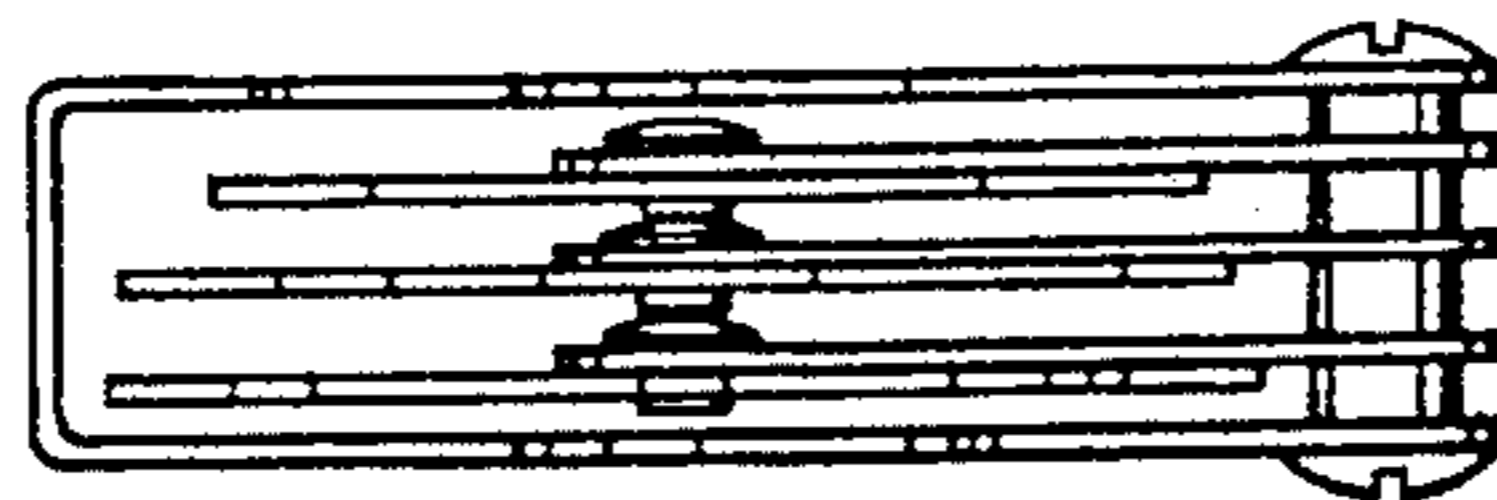

FIG 11

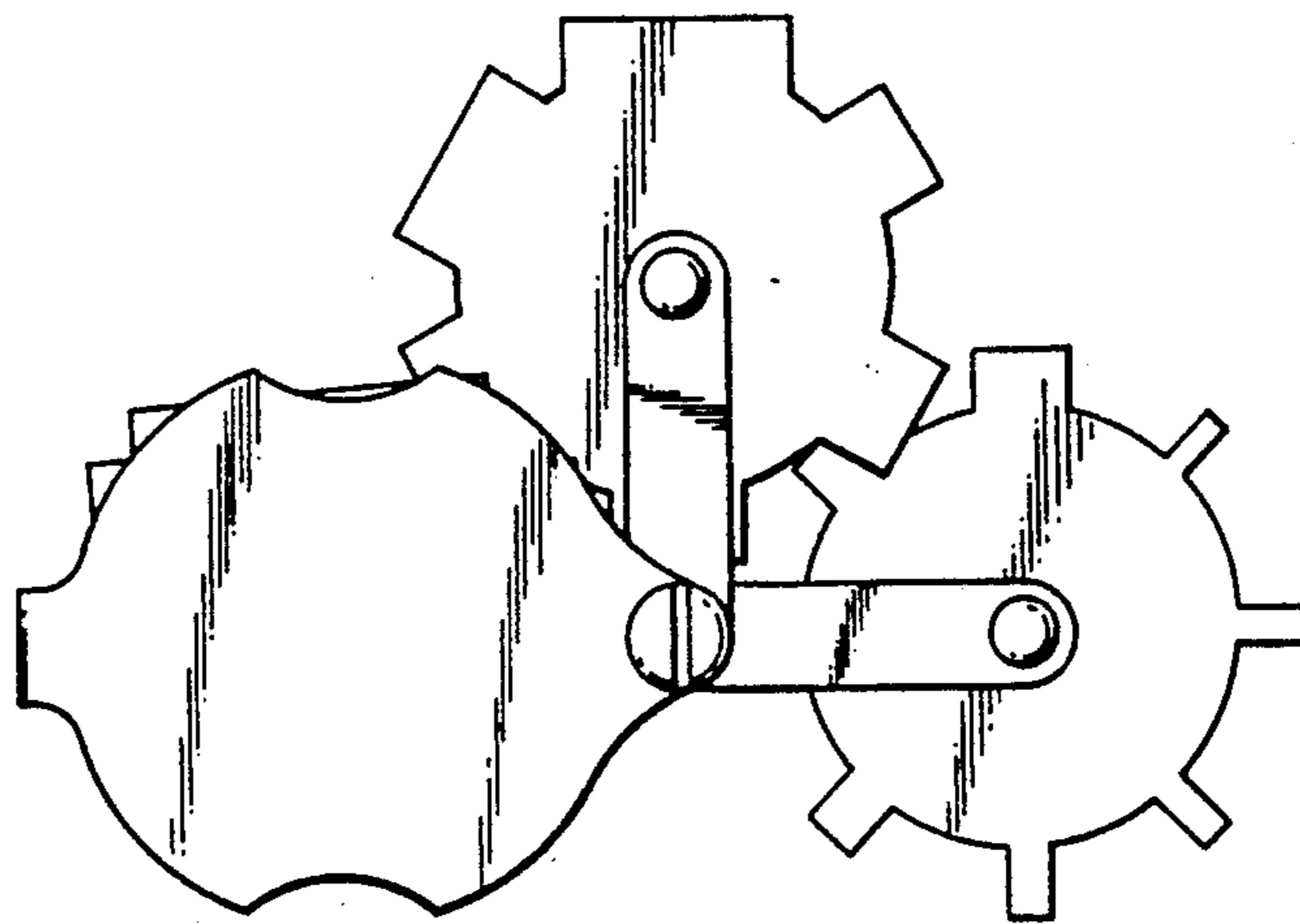

FIG 12

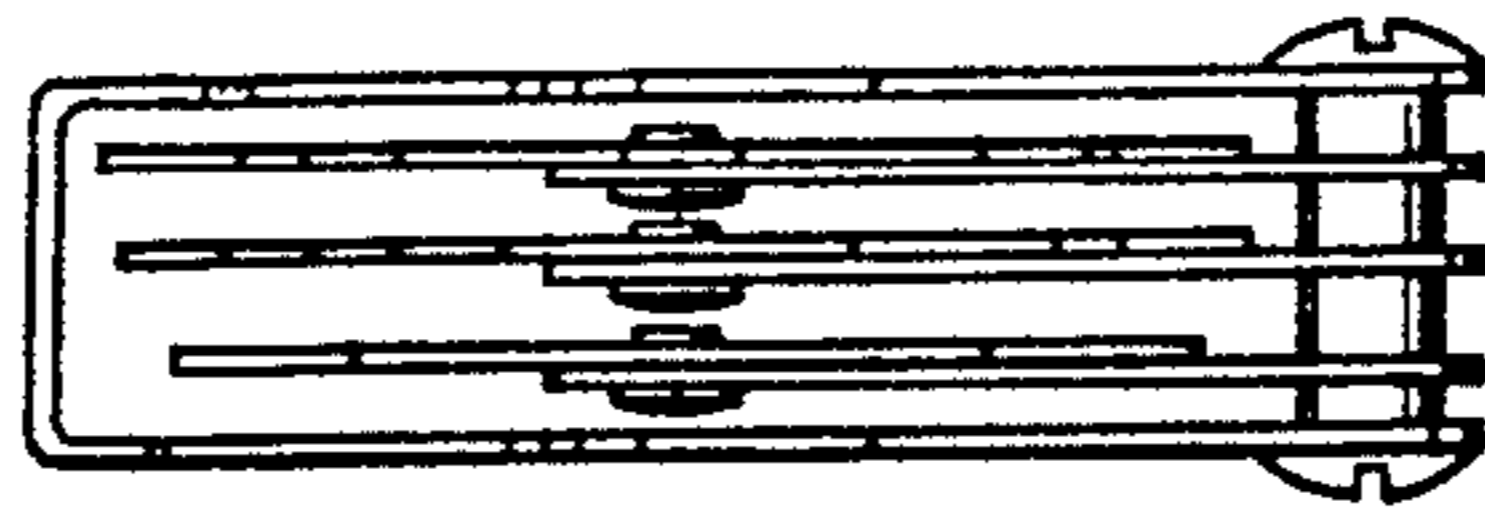

FIG 13

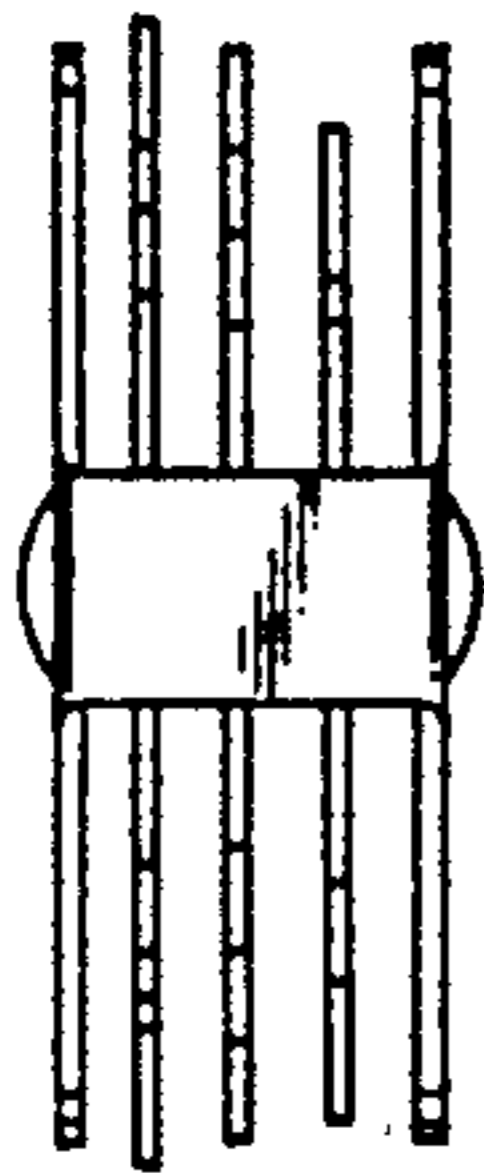

FIG 14

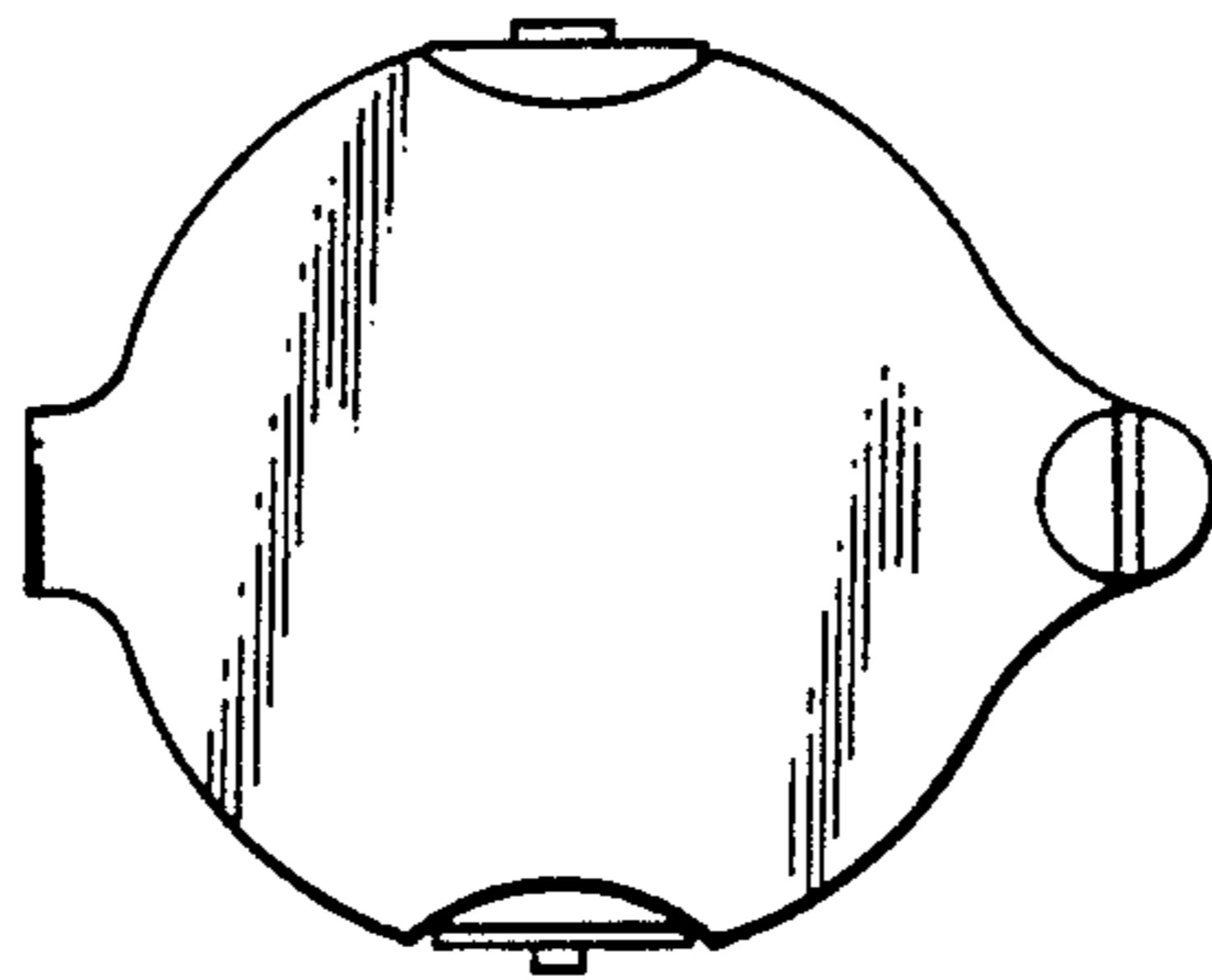

FIG 15

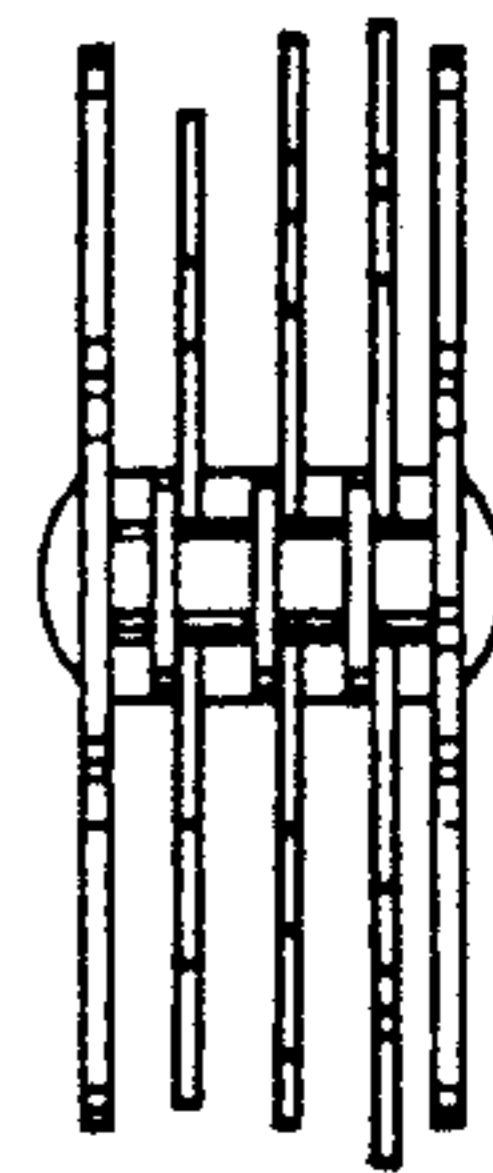

FIG 16

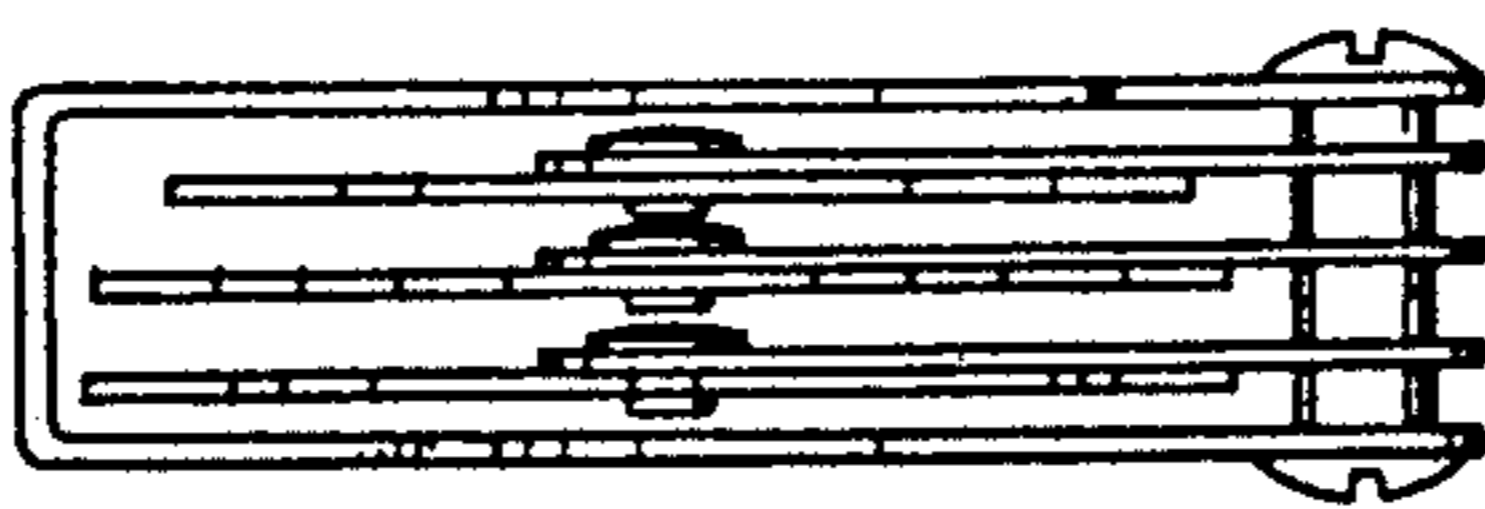

FIG 17

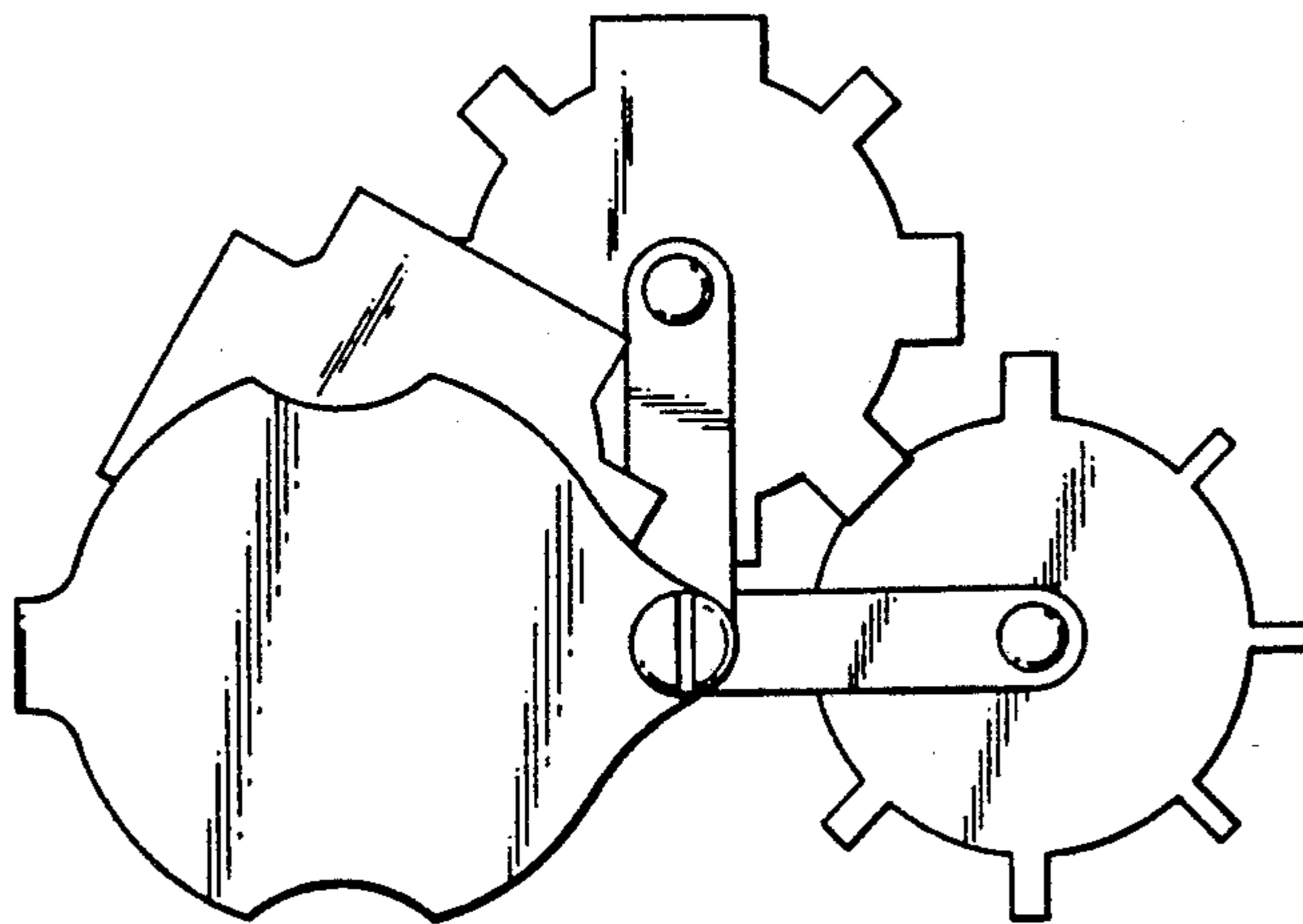

FIG 18

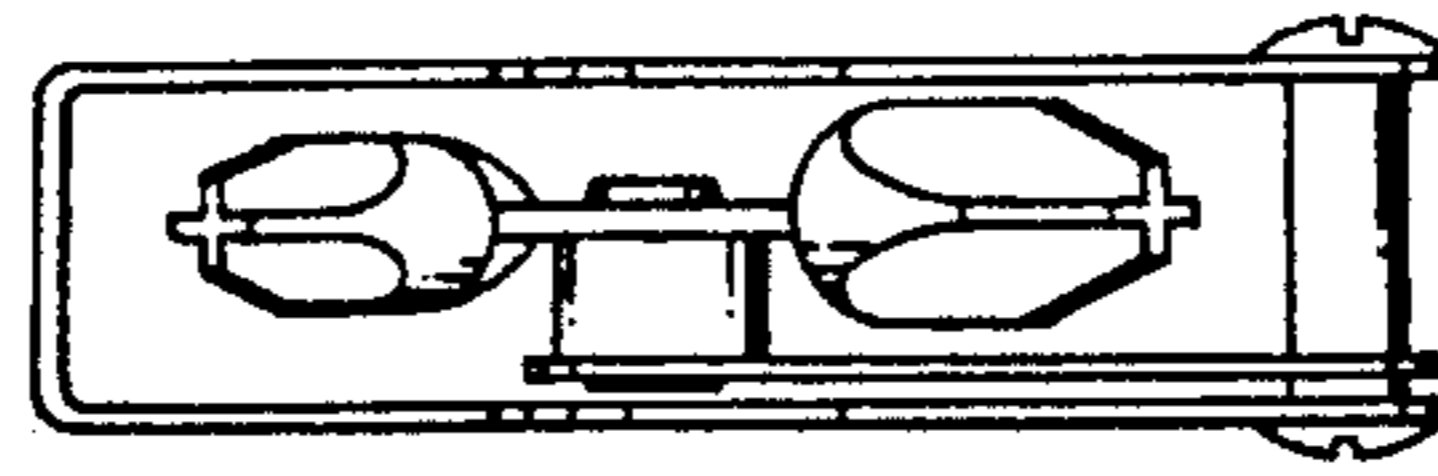

FIG 19

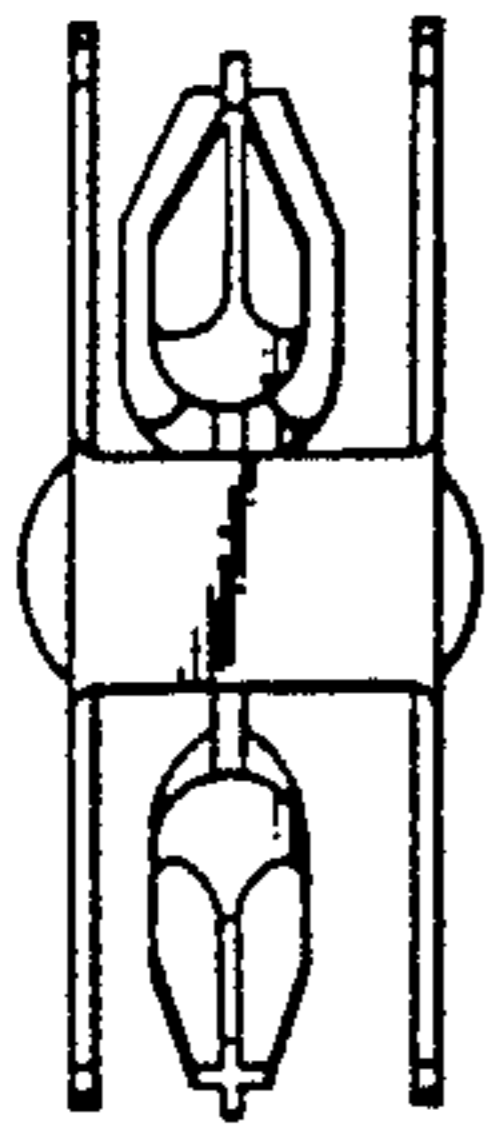

FIG 20

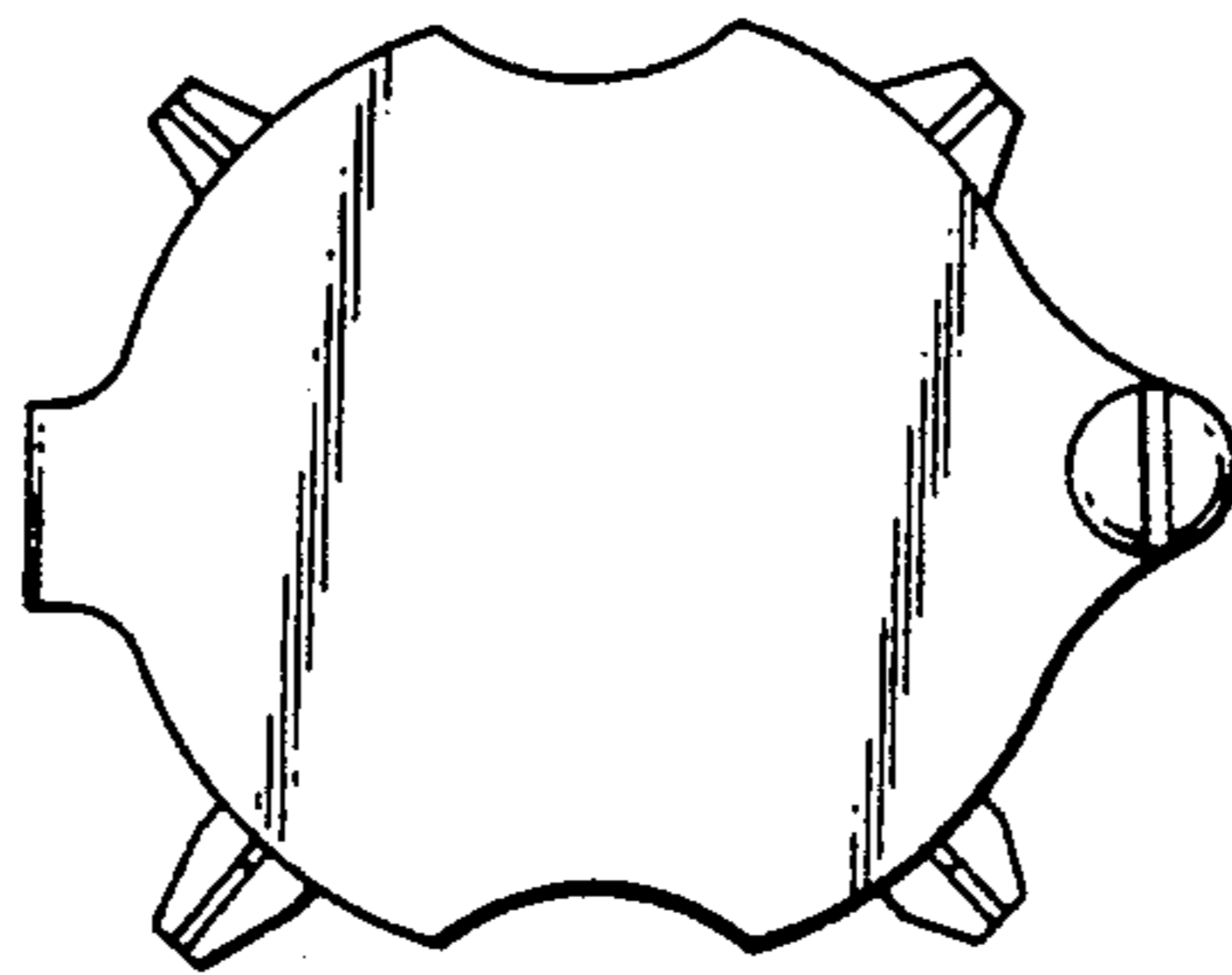

FIG 21

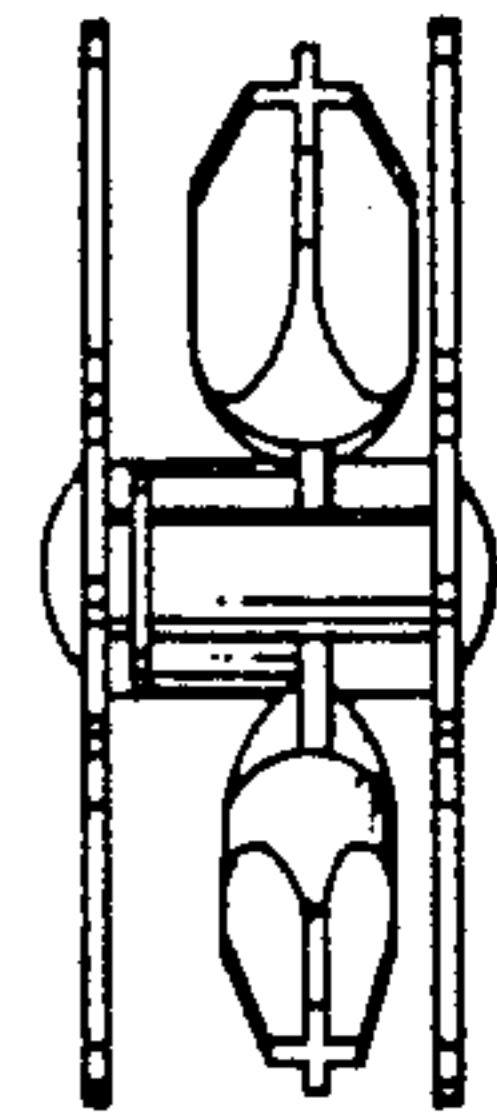

FIG 22

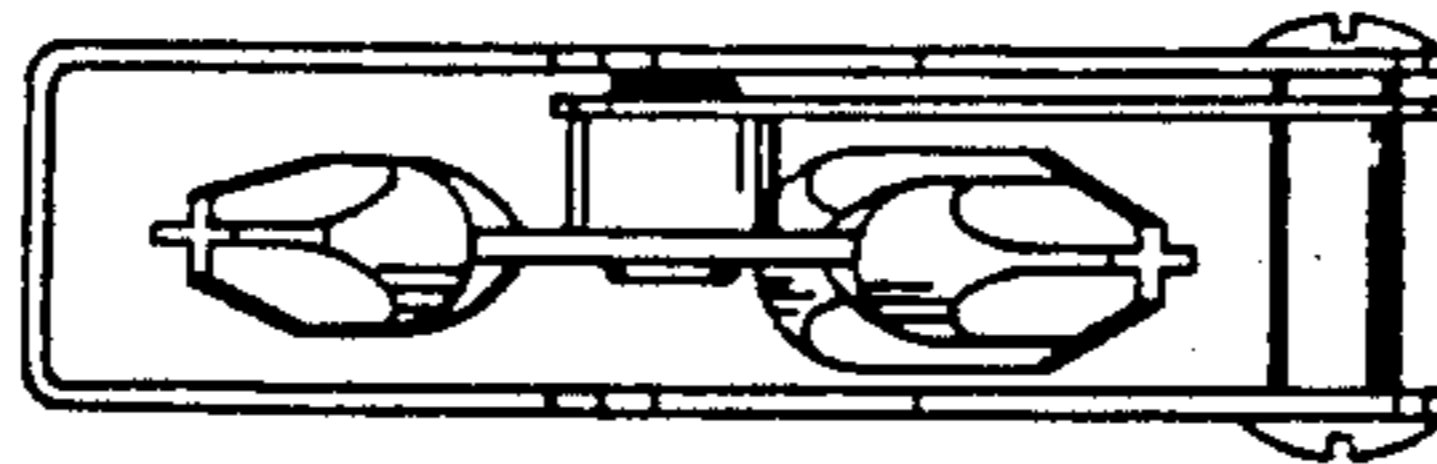

FIG 23

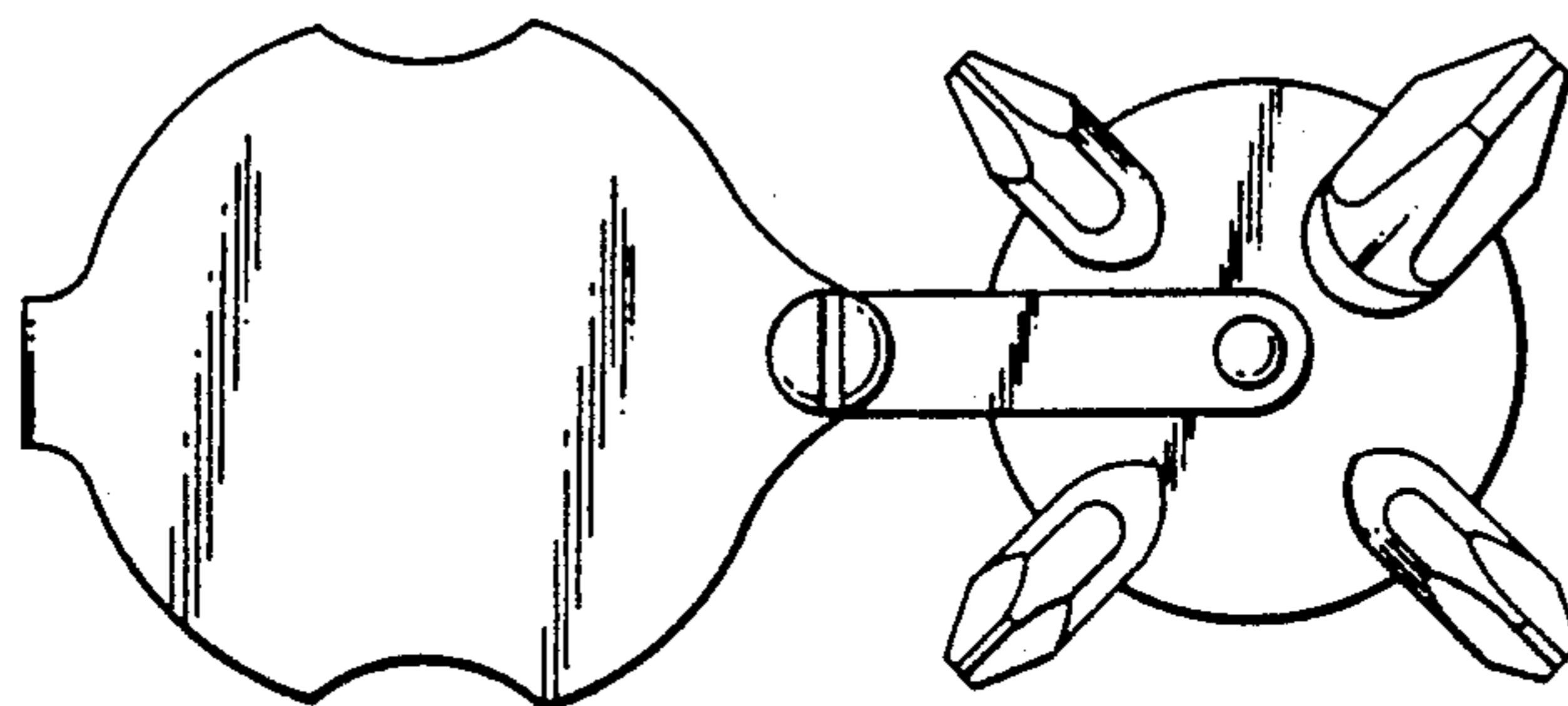

FIG 24

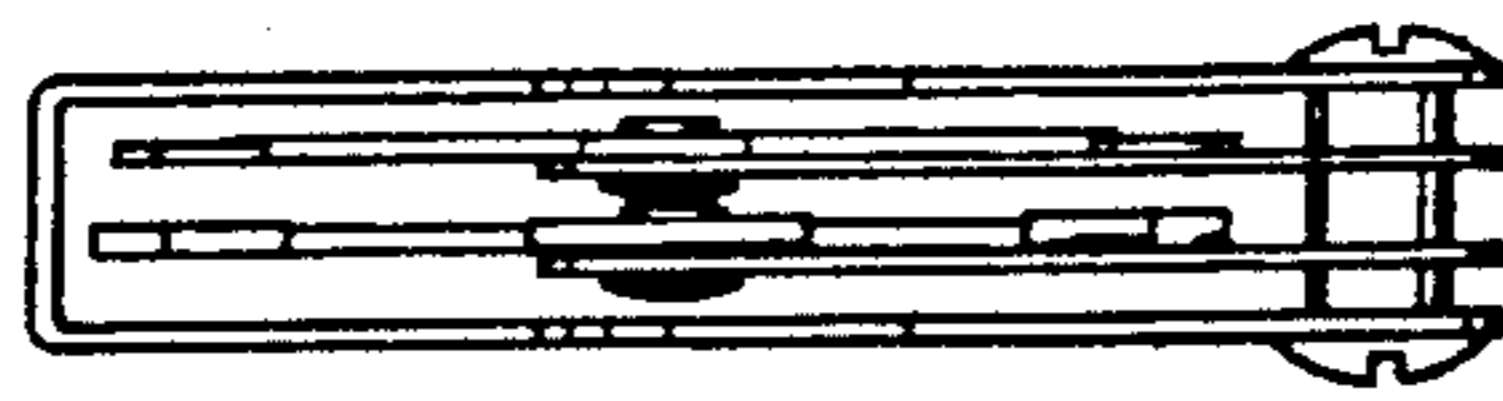

FIG 25

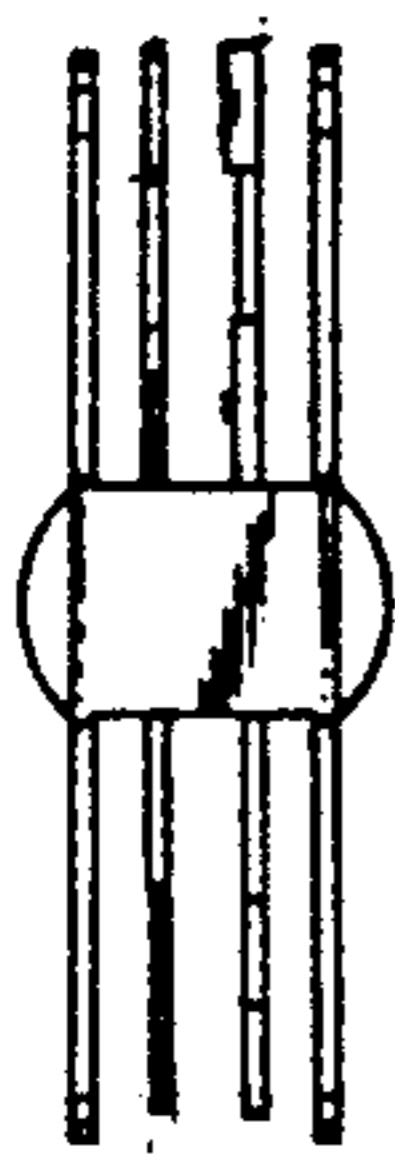

FIG 26

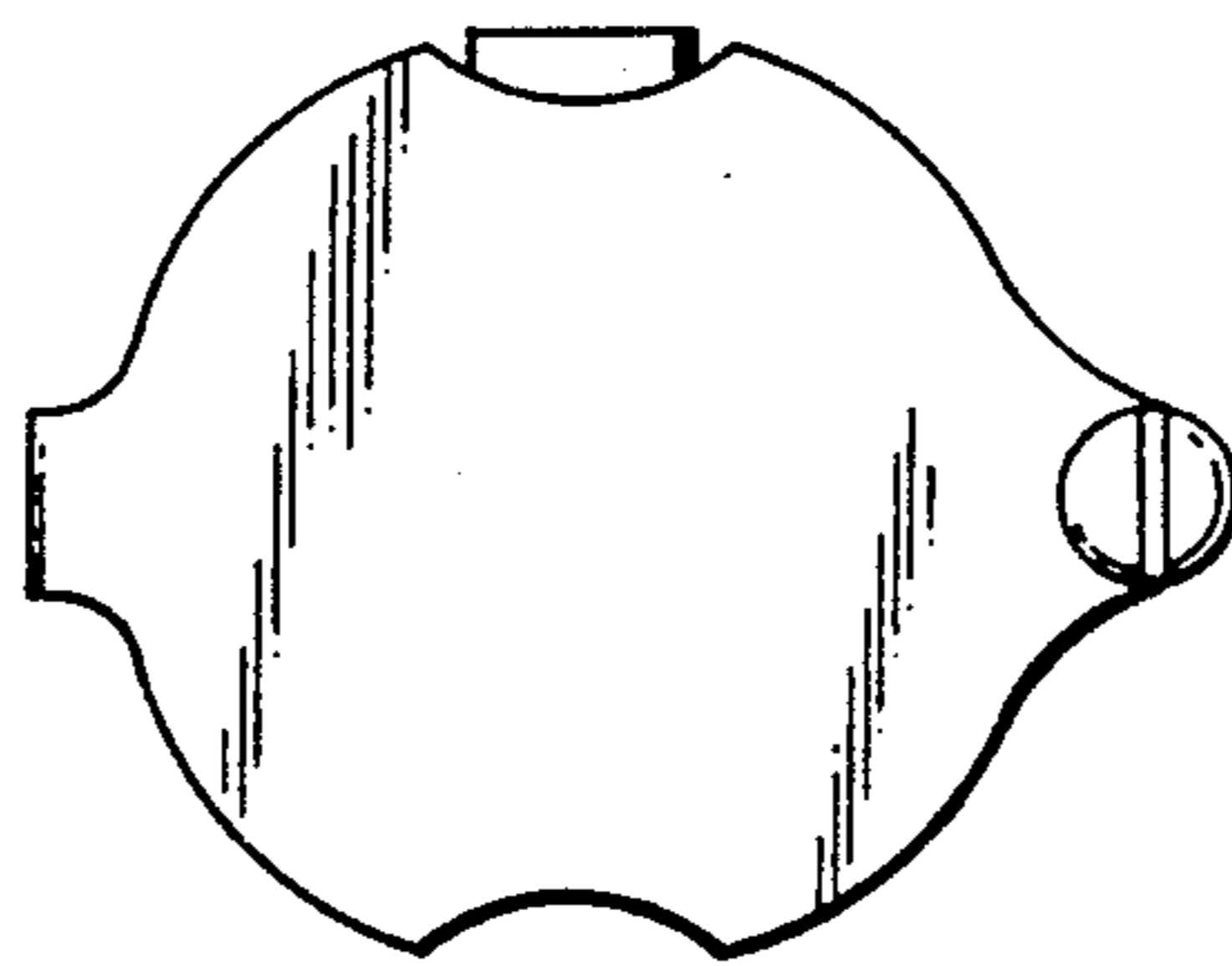

FIG 27

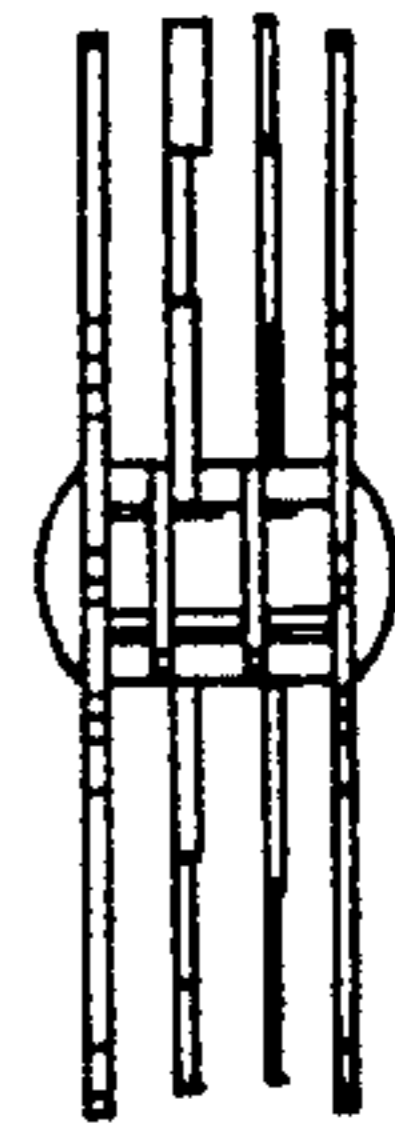

FIG 28

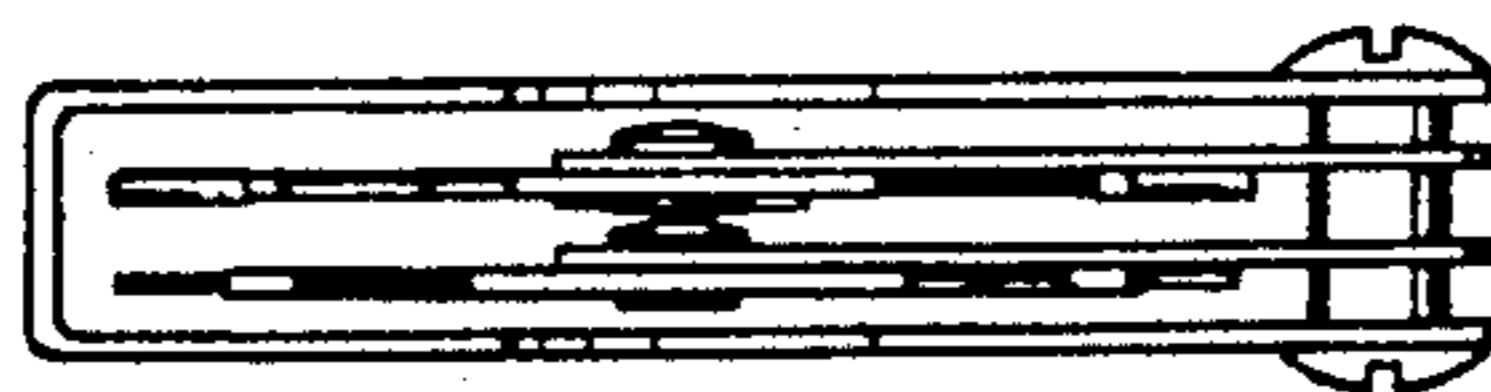

FIG 29

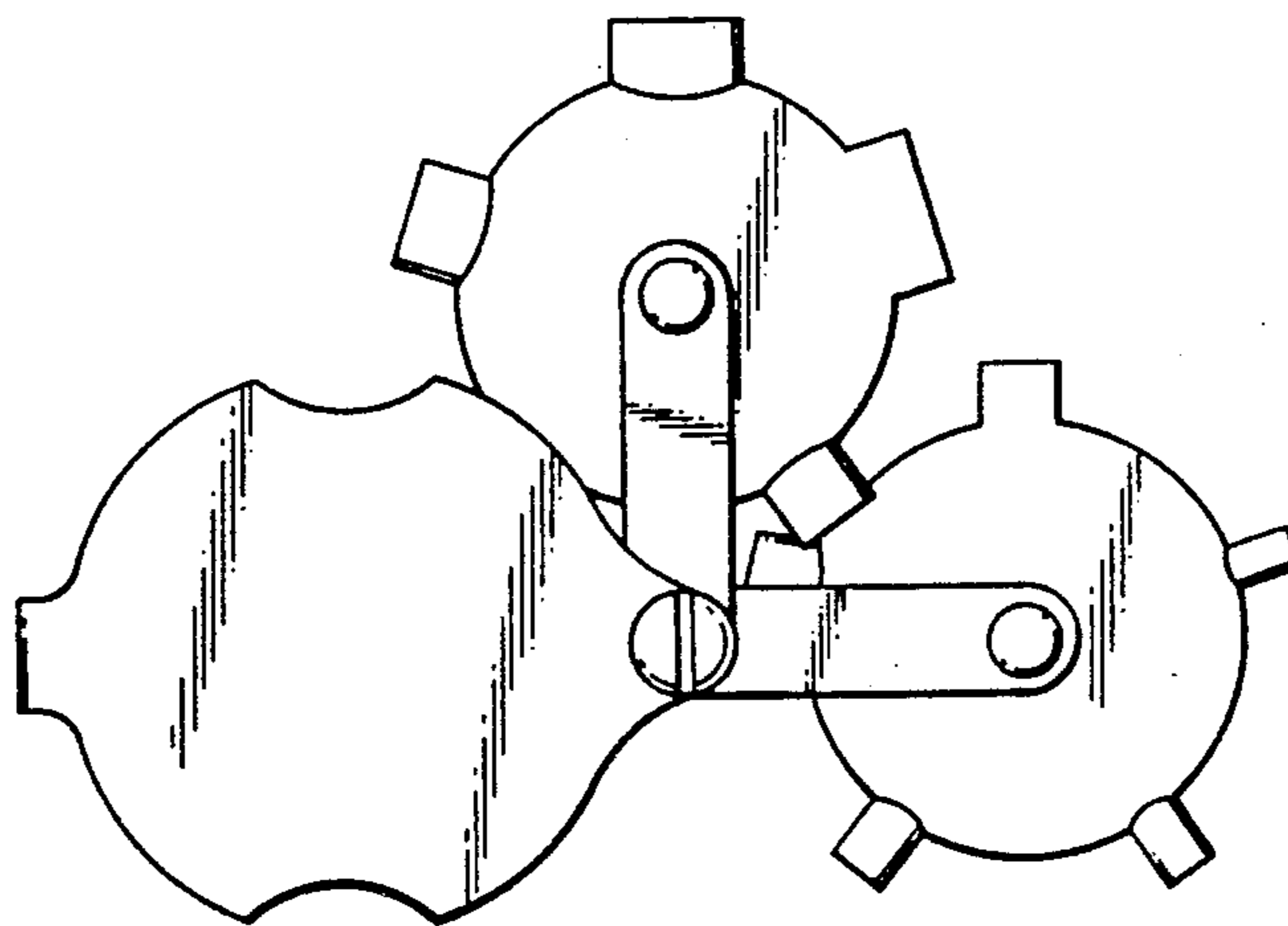

FIG 30

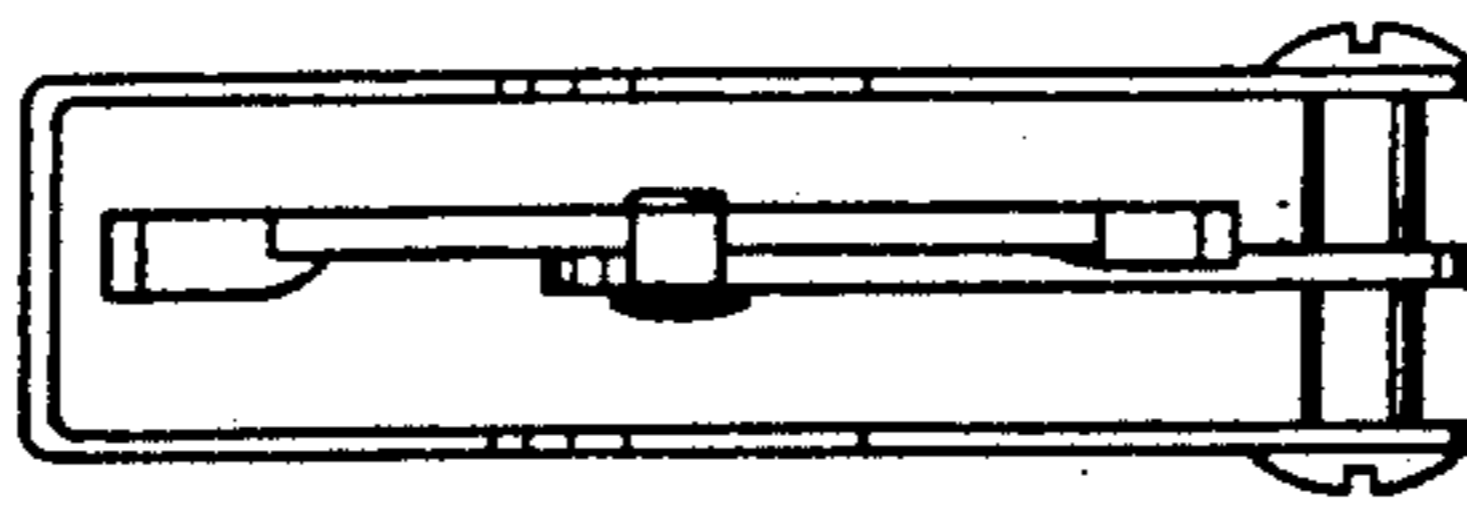

FIG 31

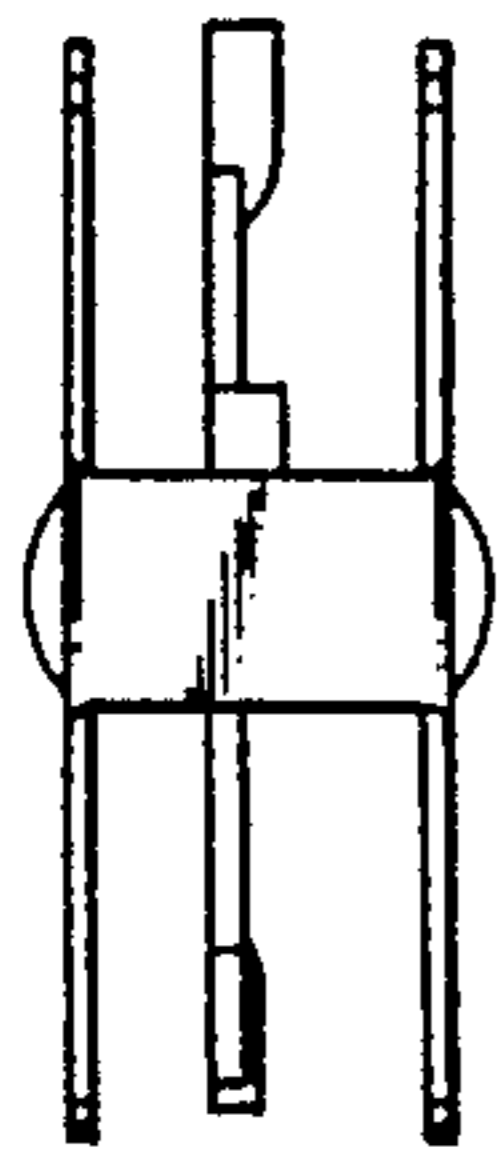

FIG 32

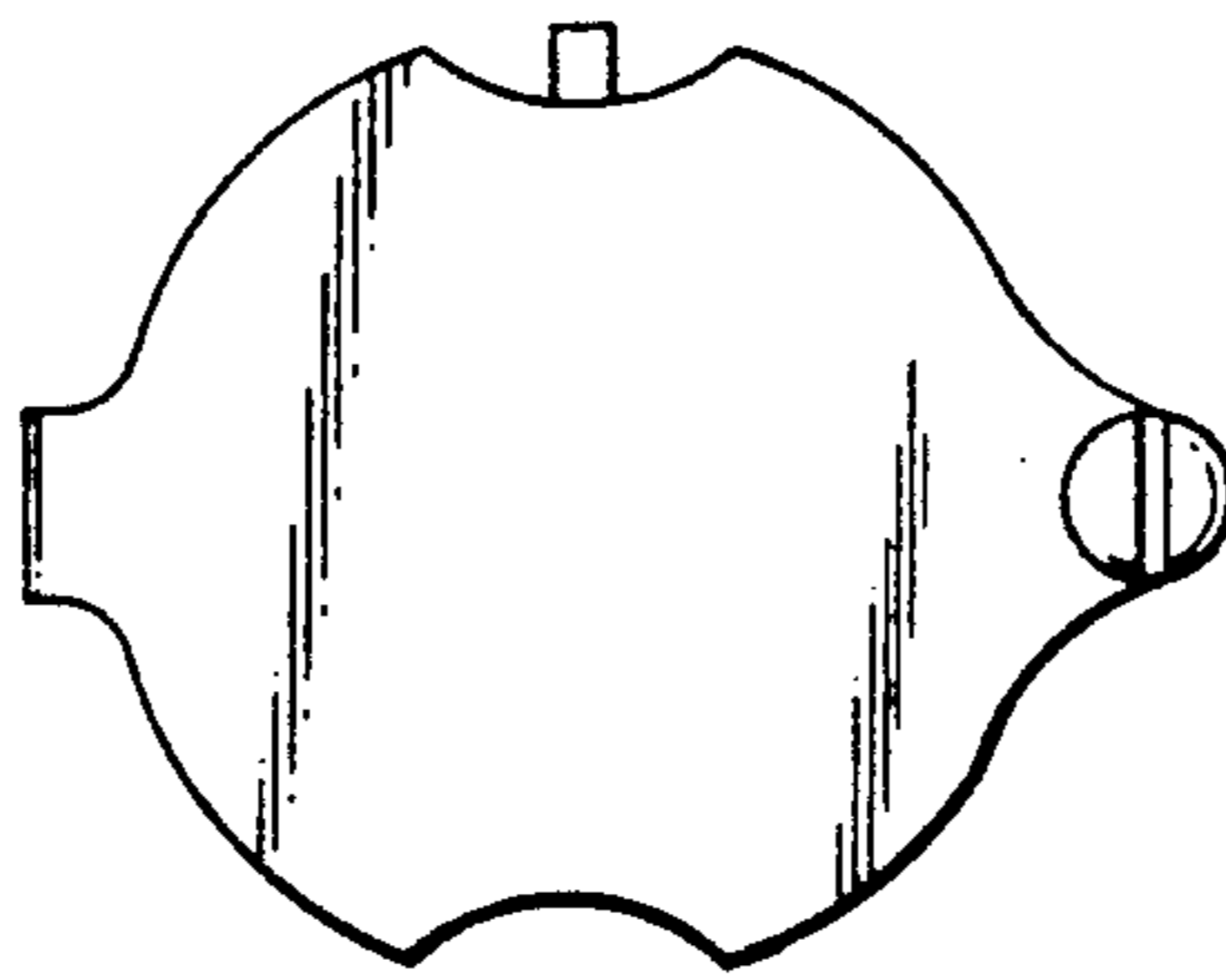

FIG 33

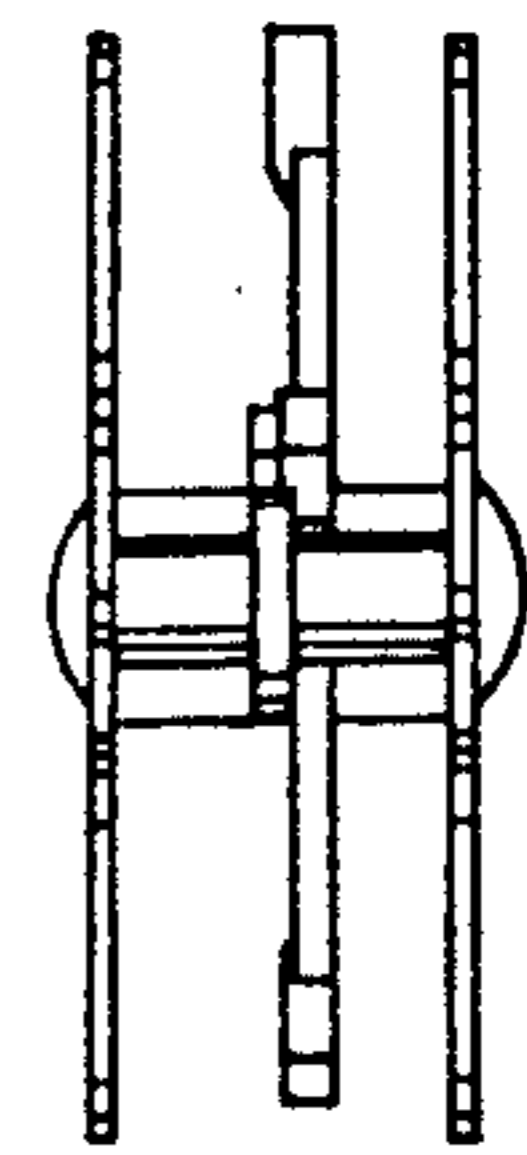

FIG 34

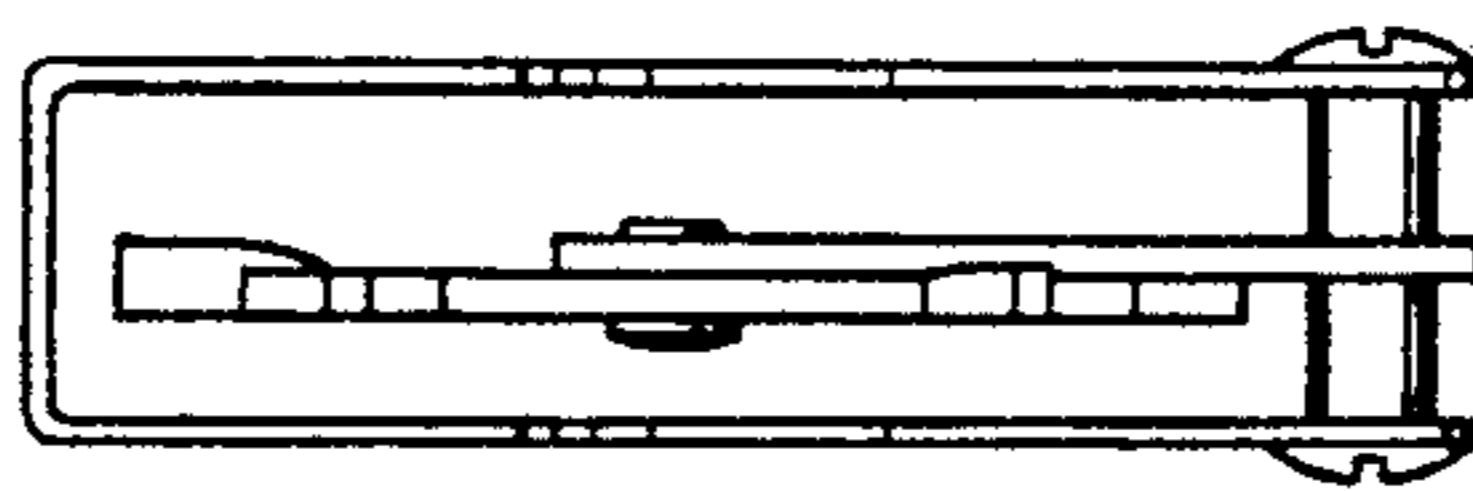

FIG 35

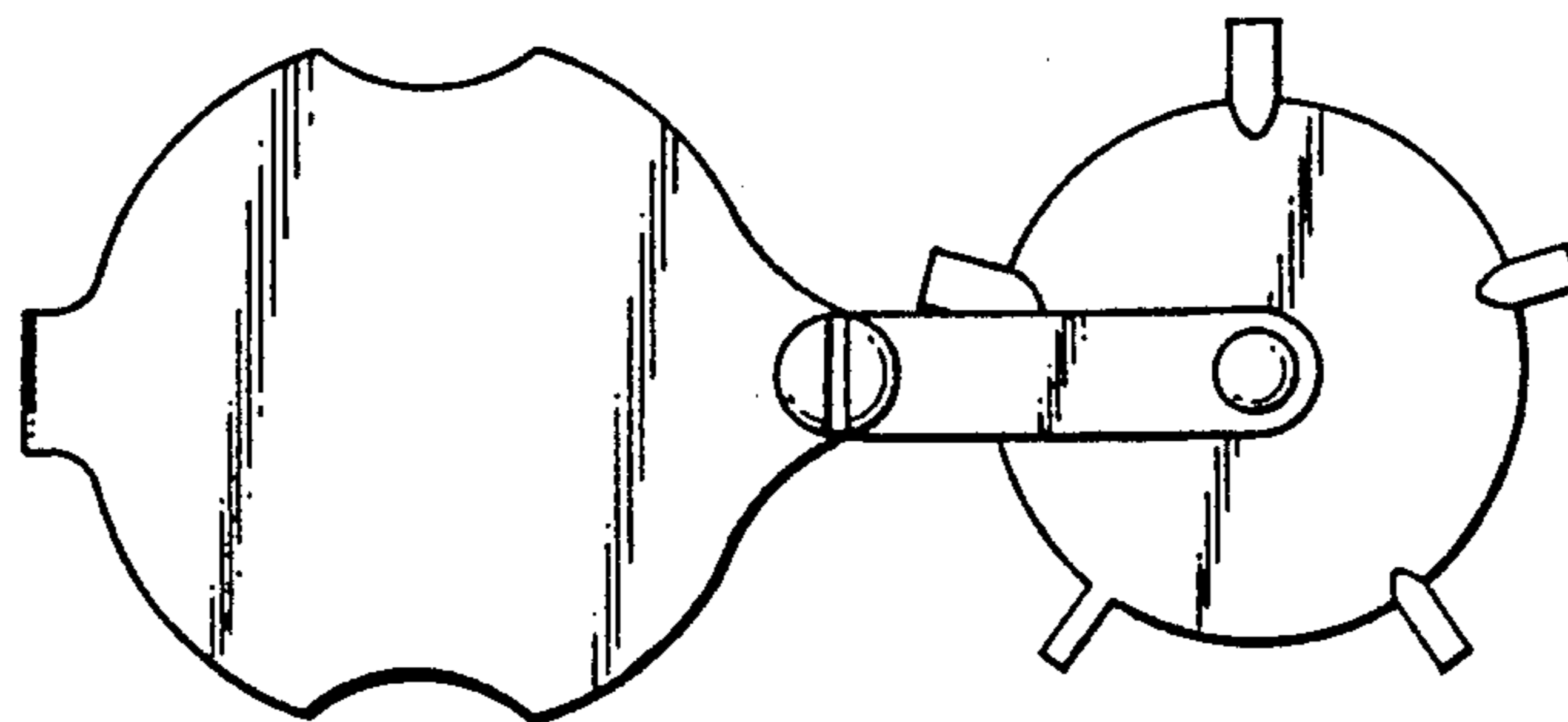

FIG 36

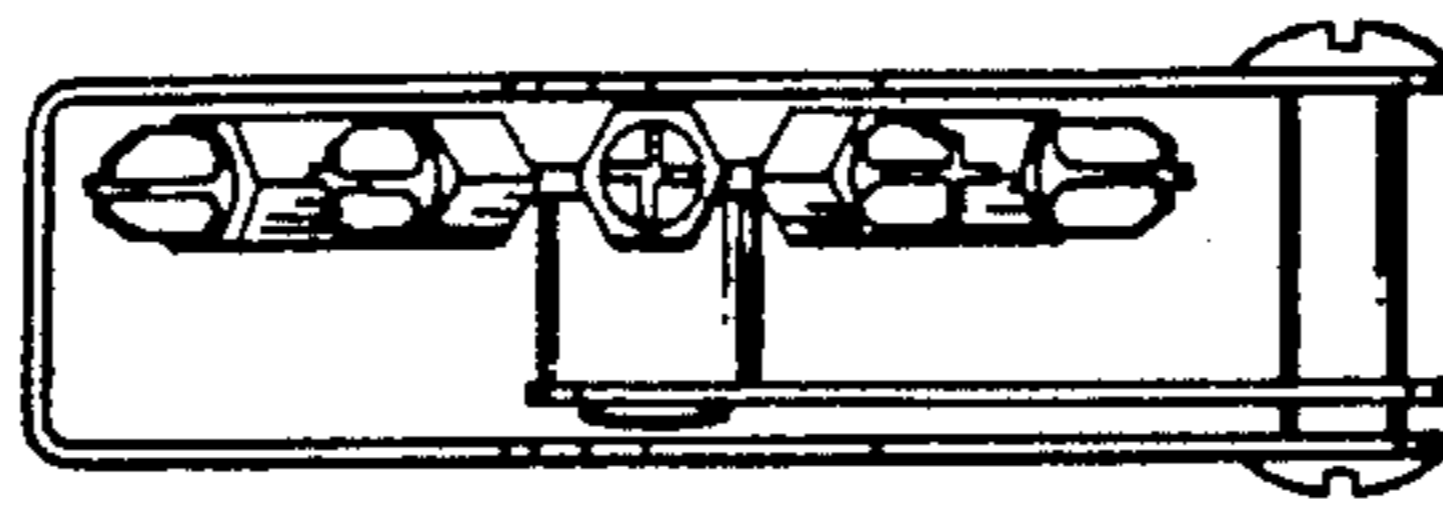

FIG 37

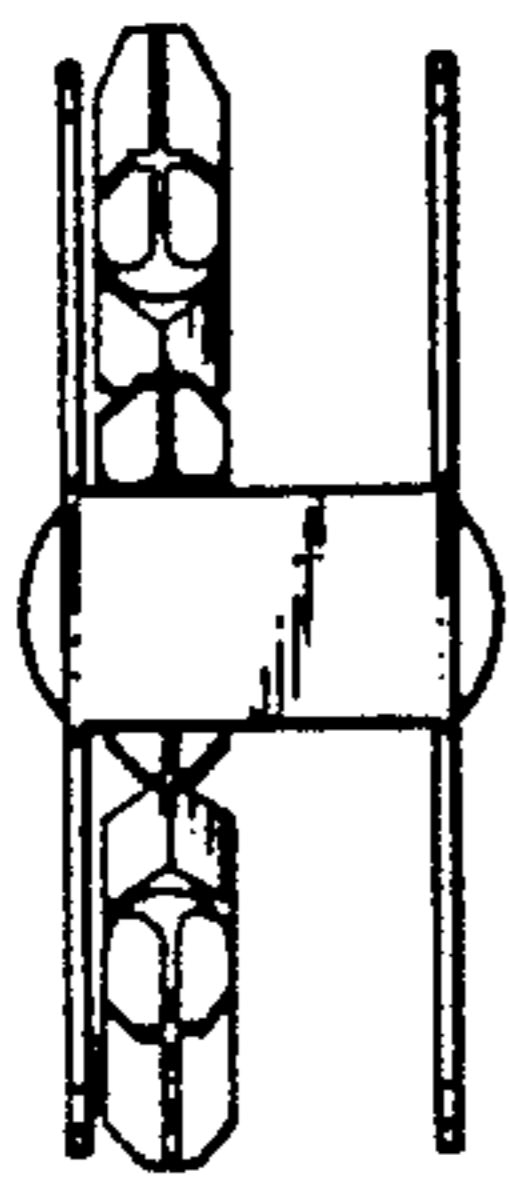

FIG 38

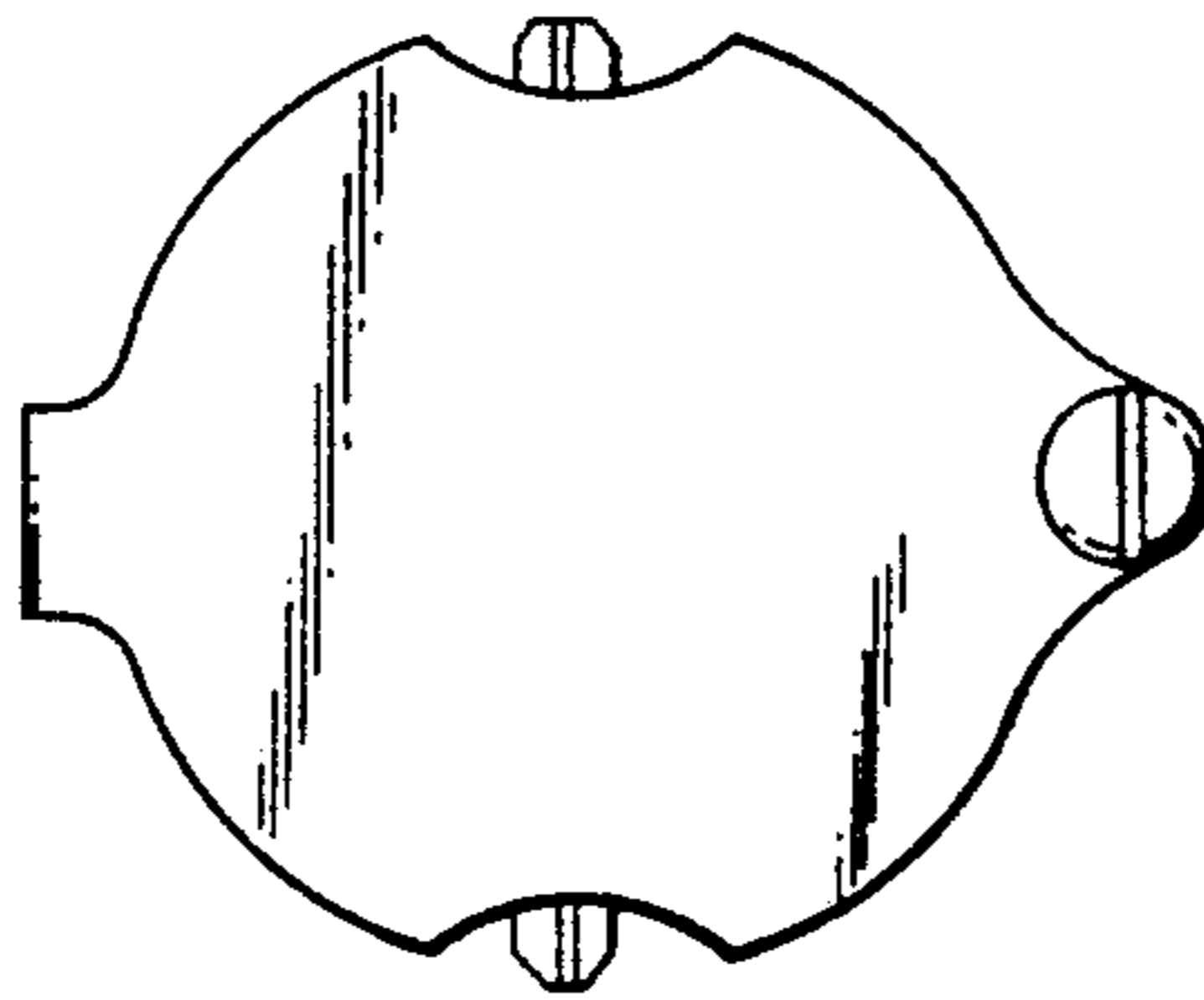

FIG 39

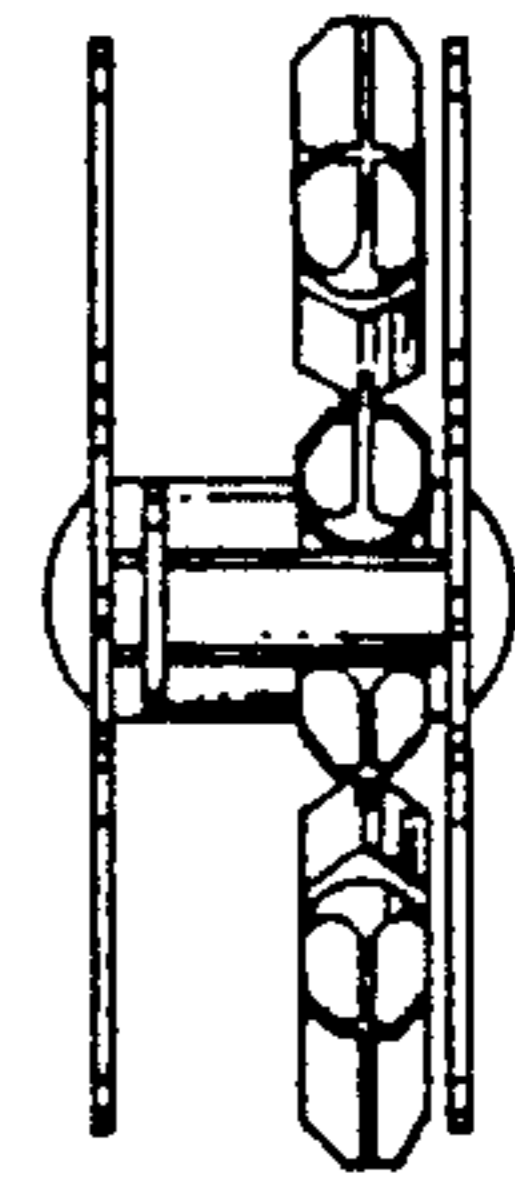

FIG 40

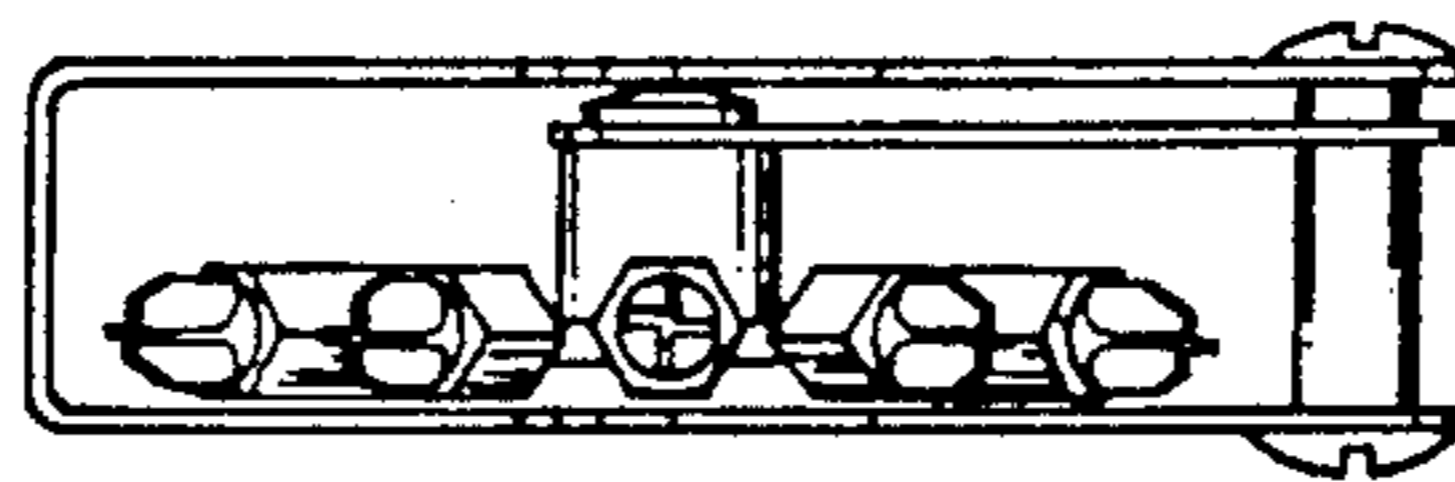

FIG 41

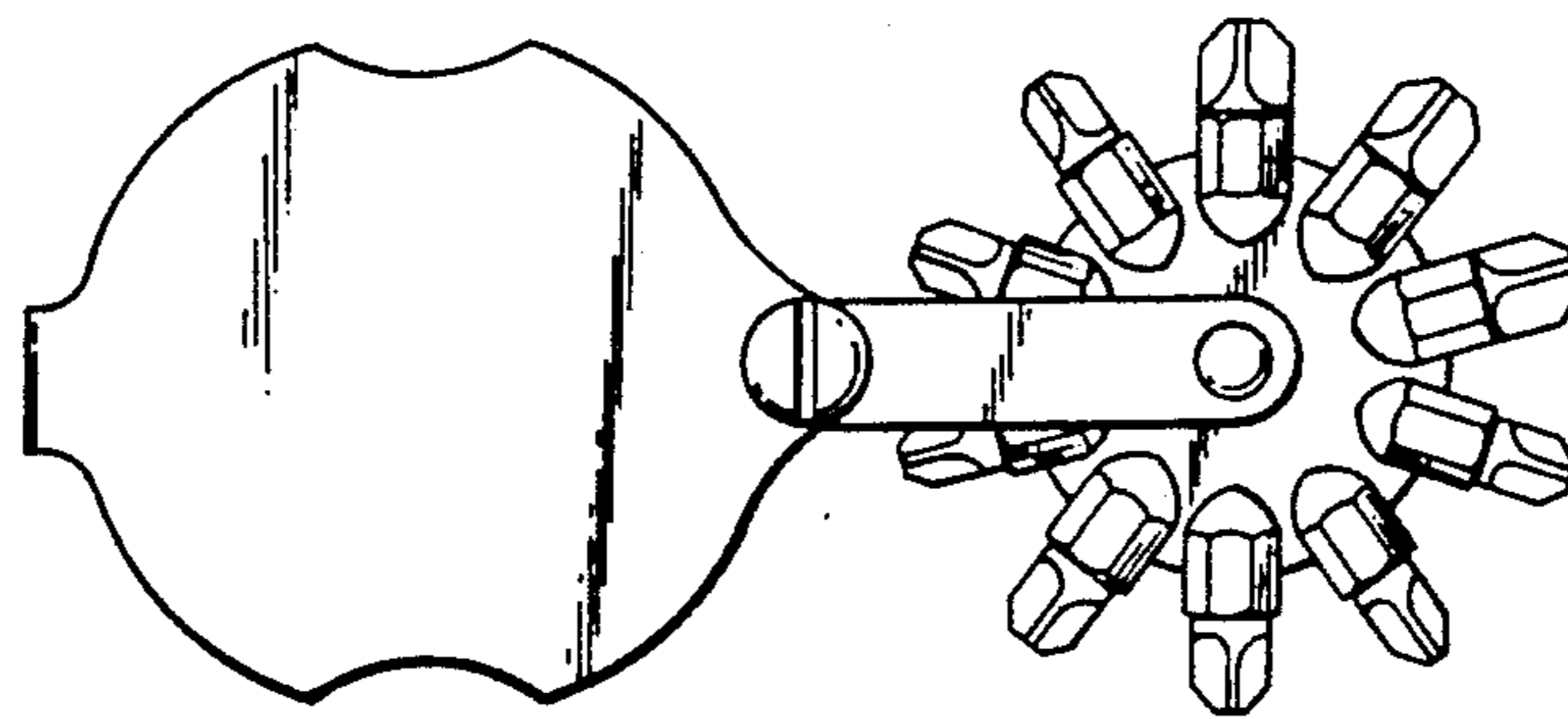

FIG 42

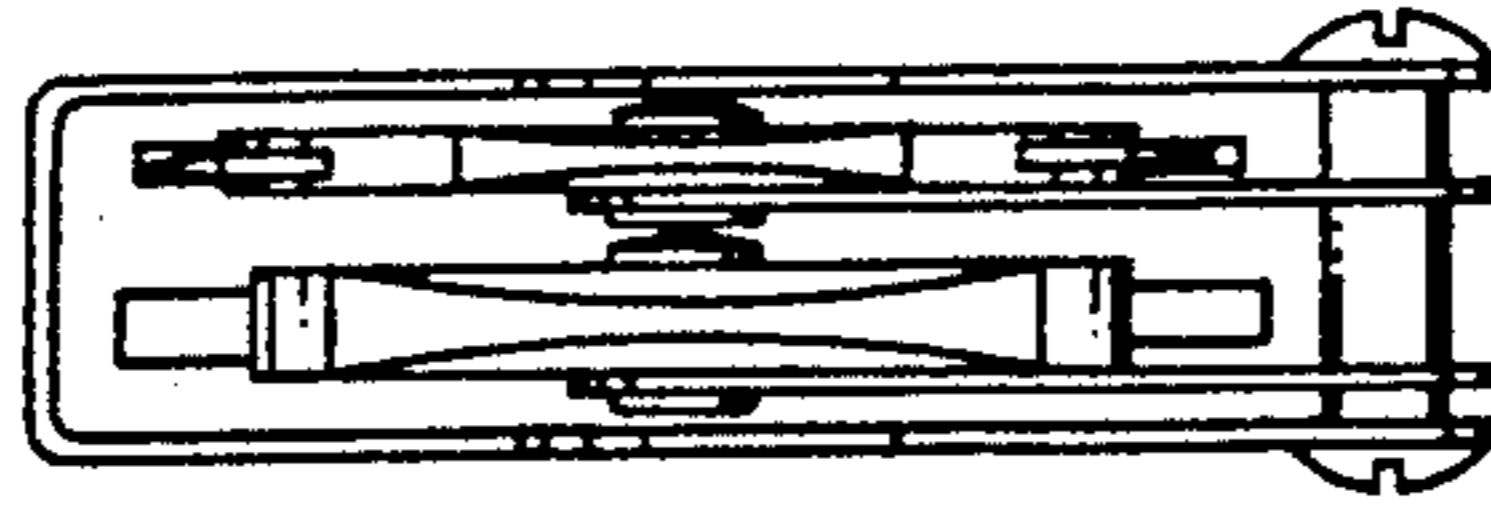

FIG 43

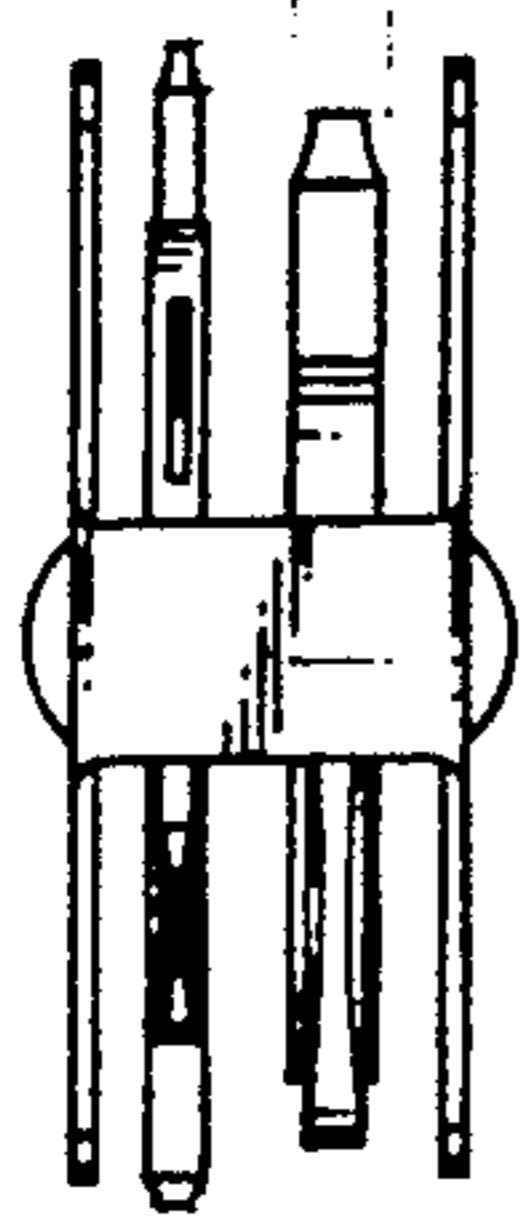

FIG 44

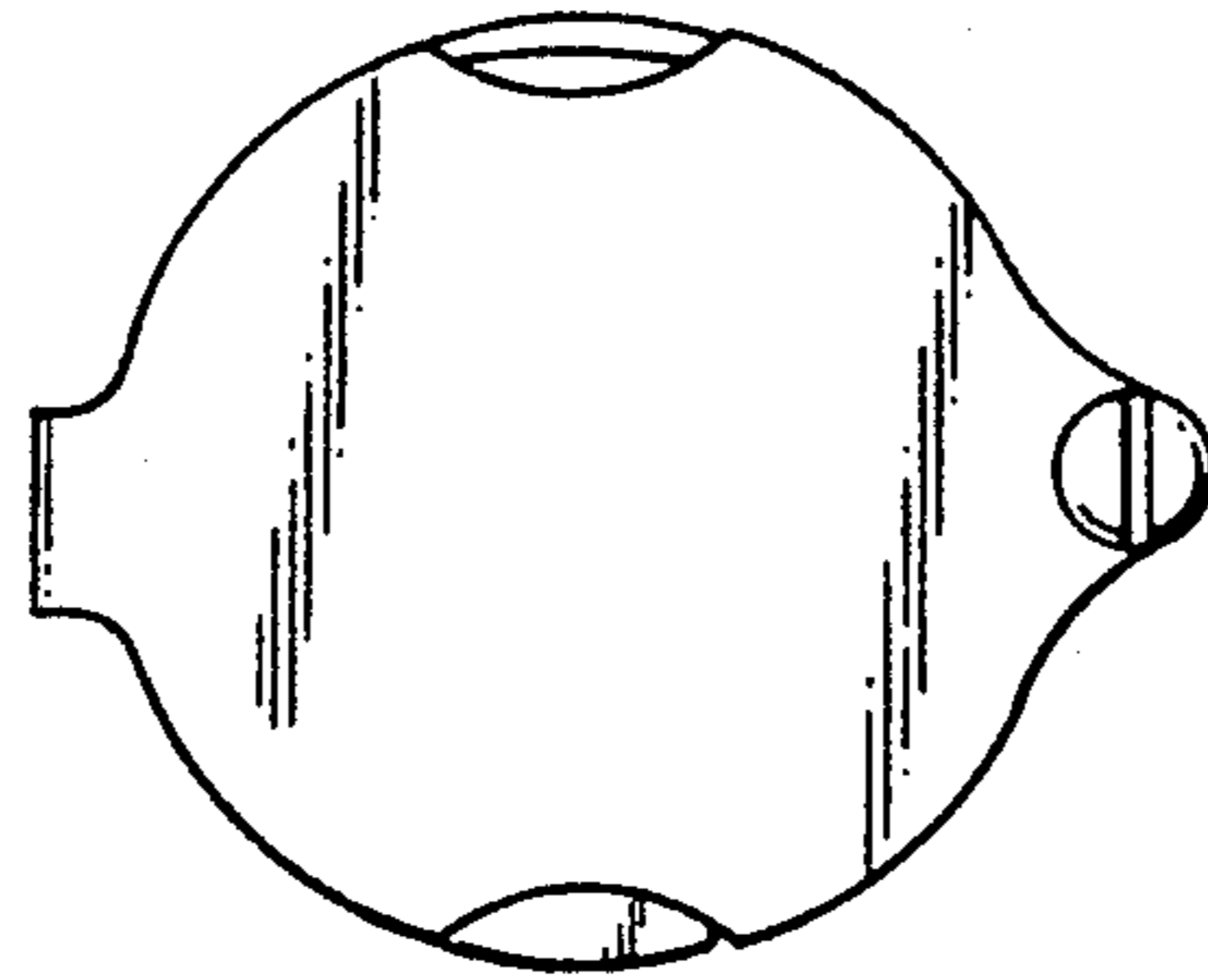

FIG 45

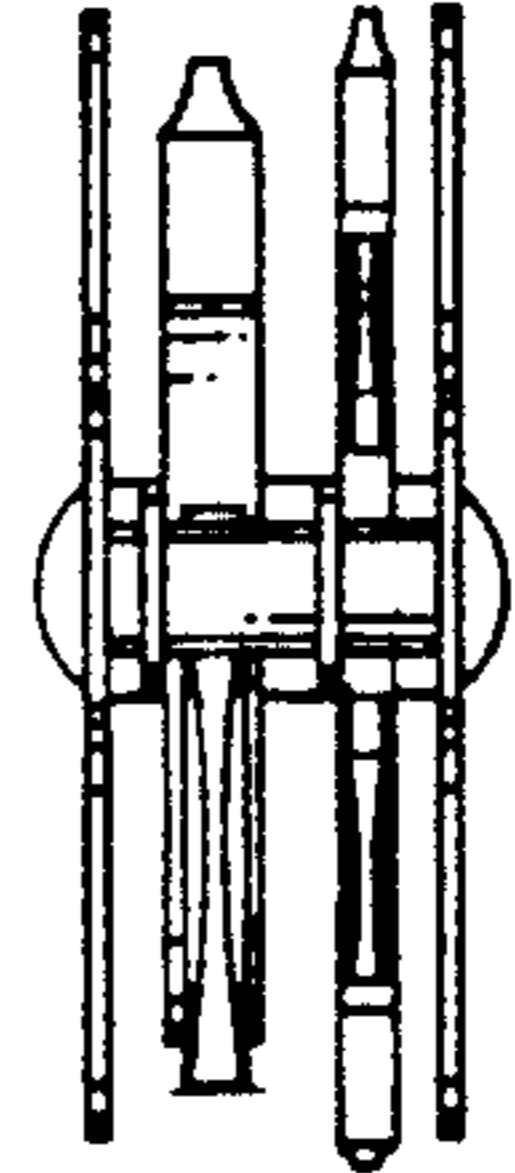

FIG 46

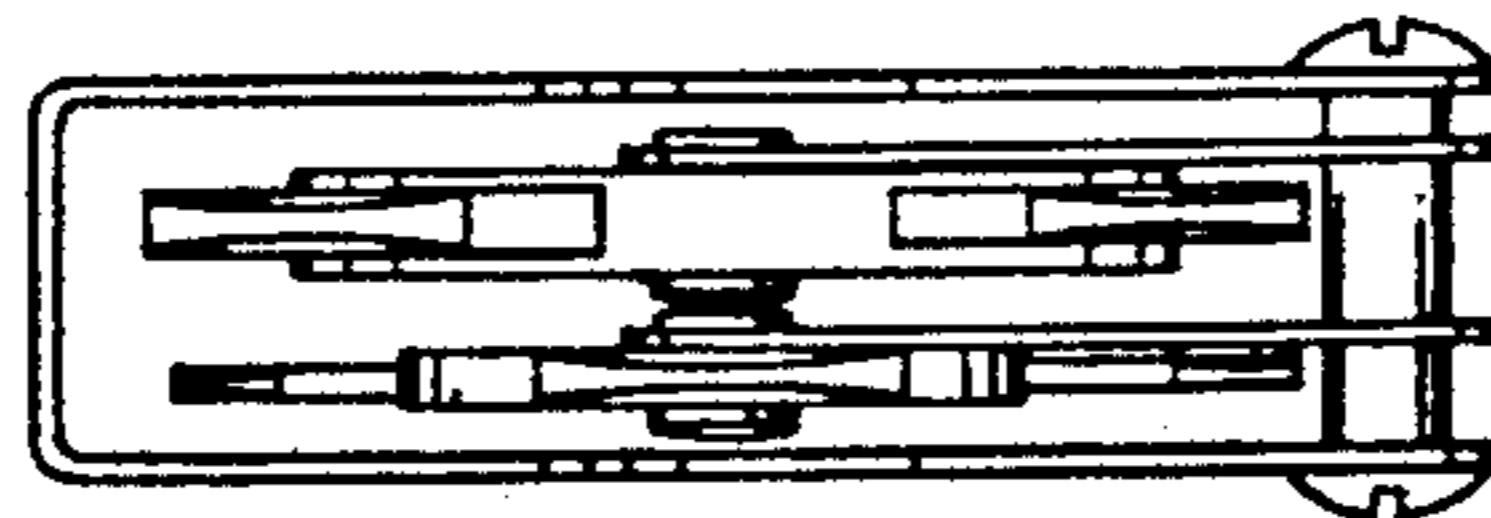

FIG 47

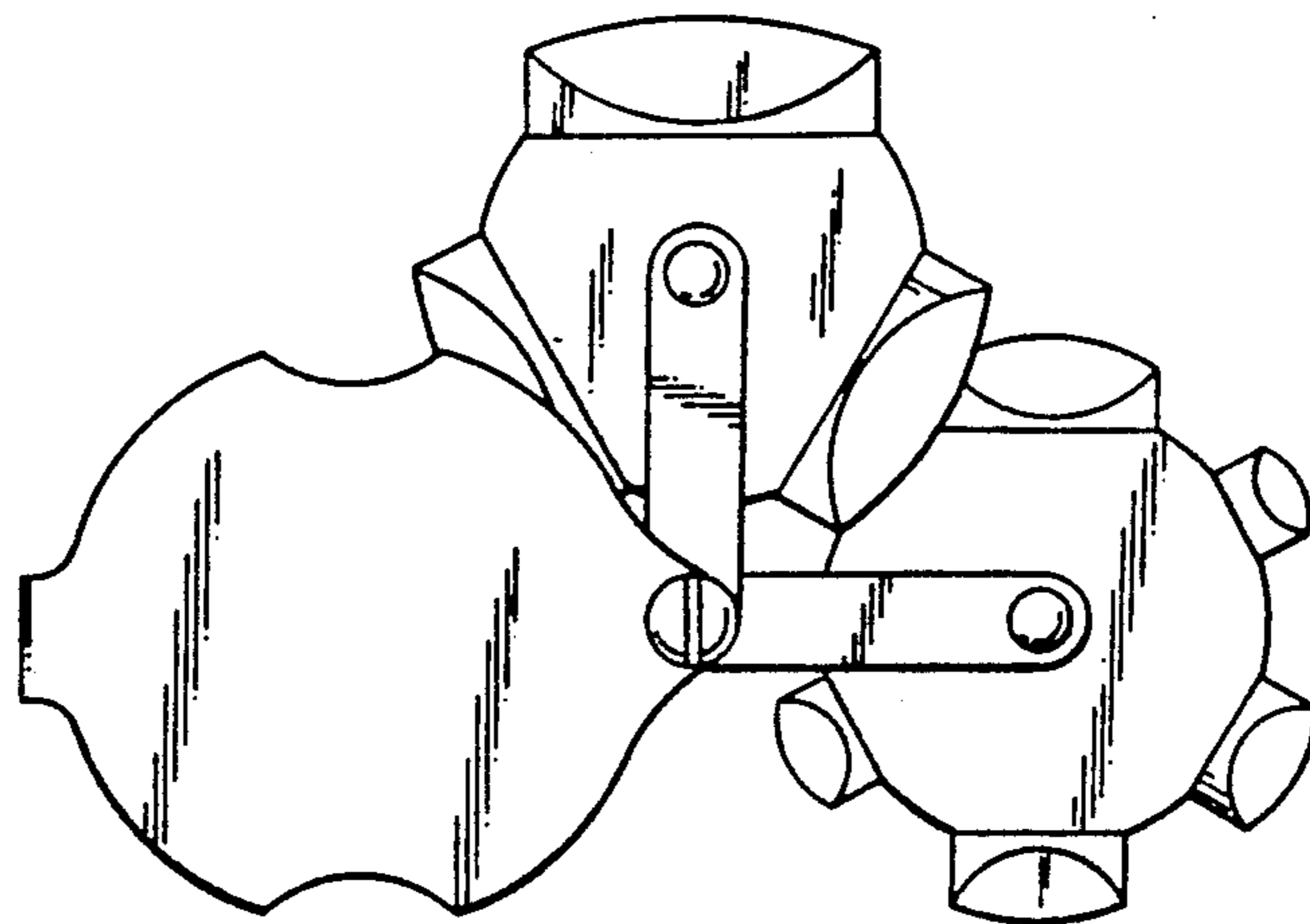

FIG 48

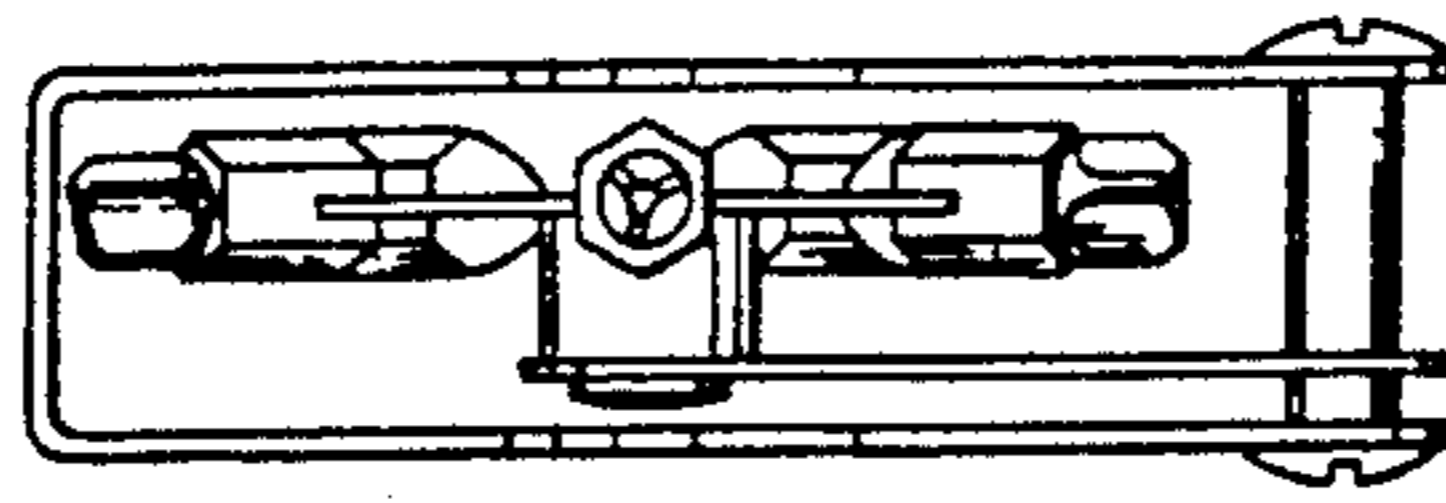

FIG 49

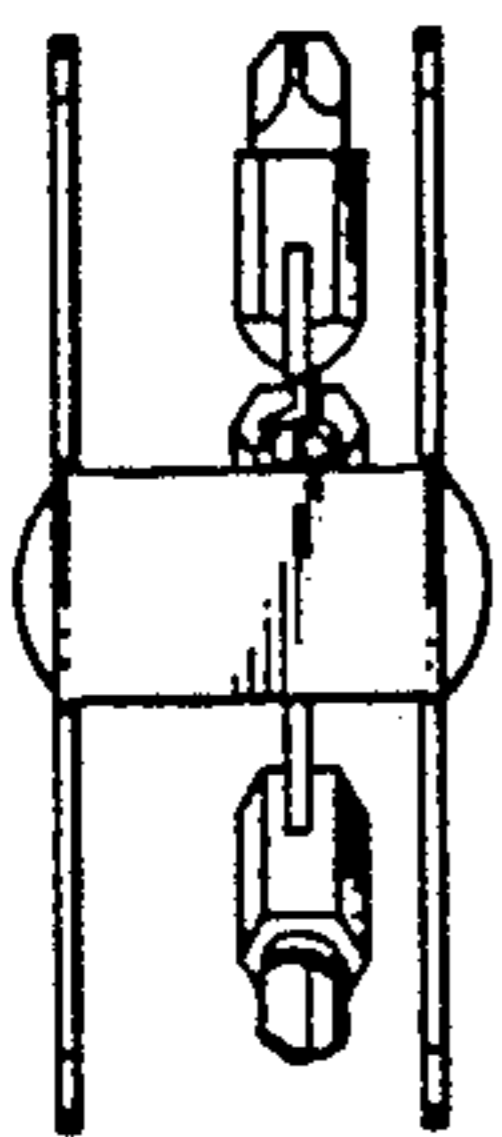

FIG 50

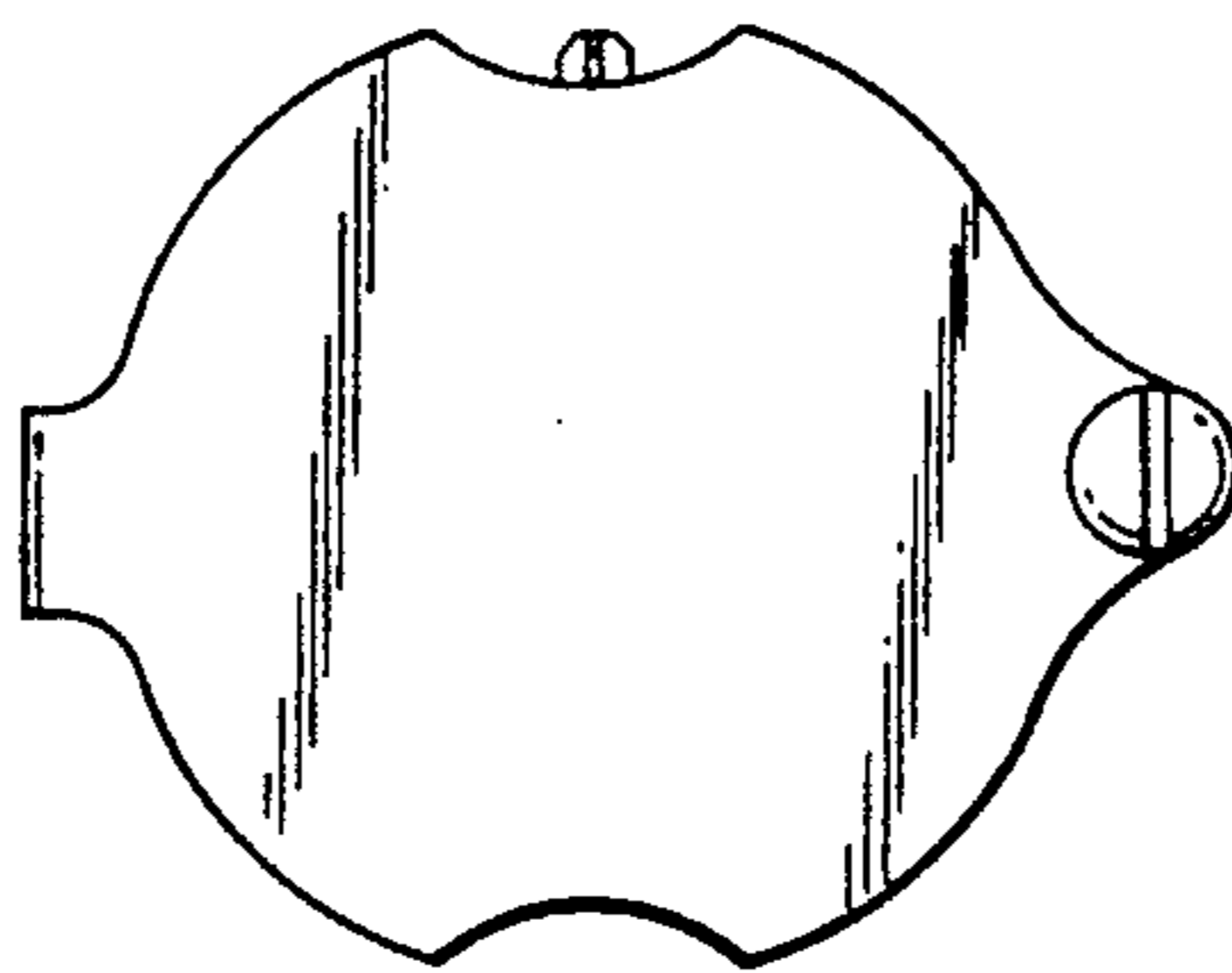

FIG 51

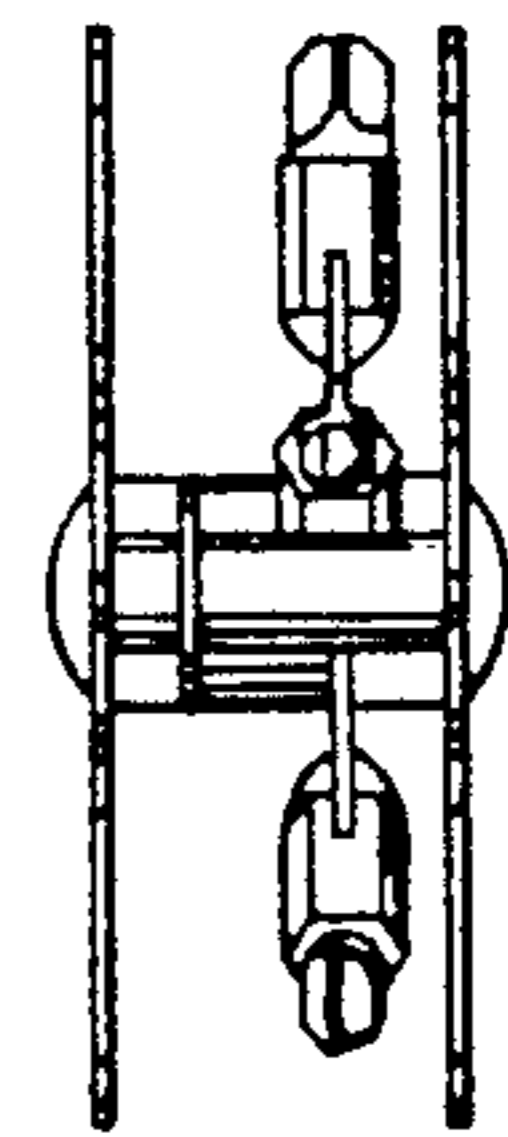

FIG 52

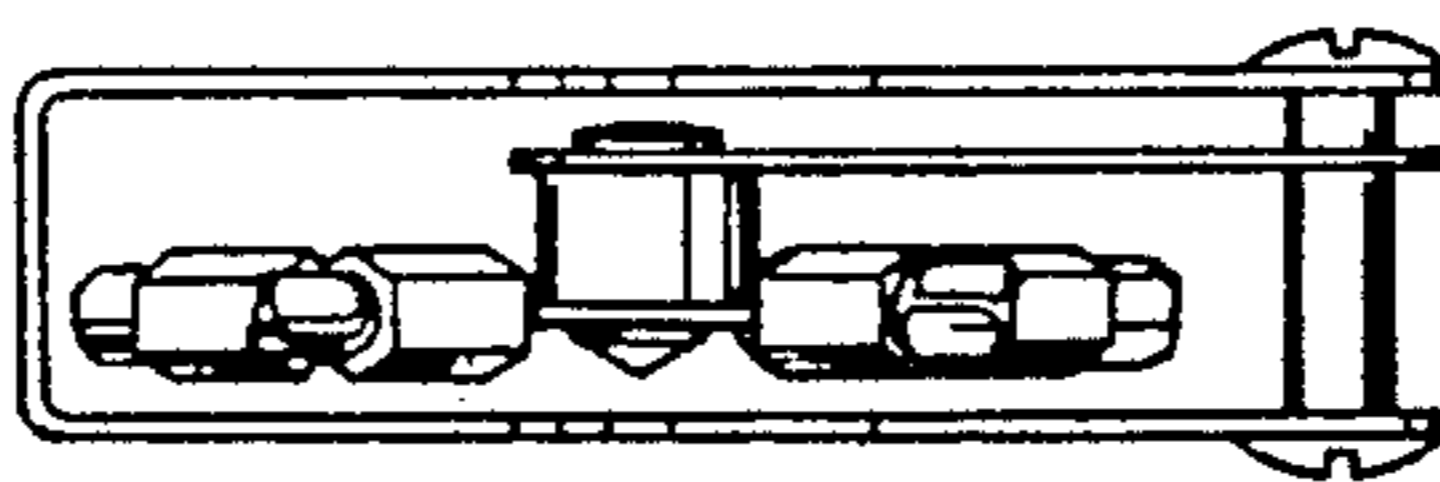

FIG 53

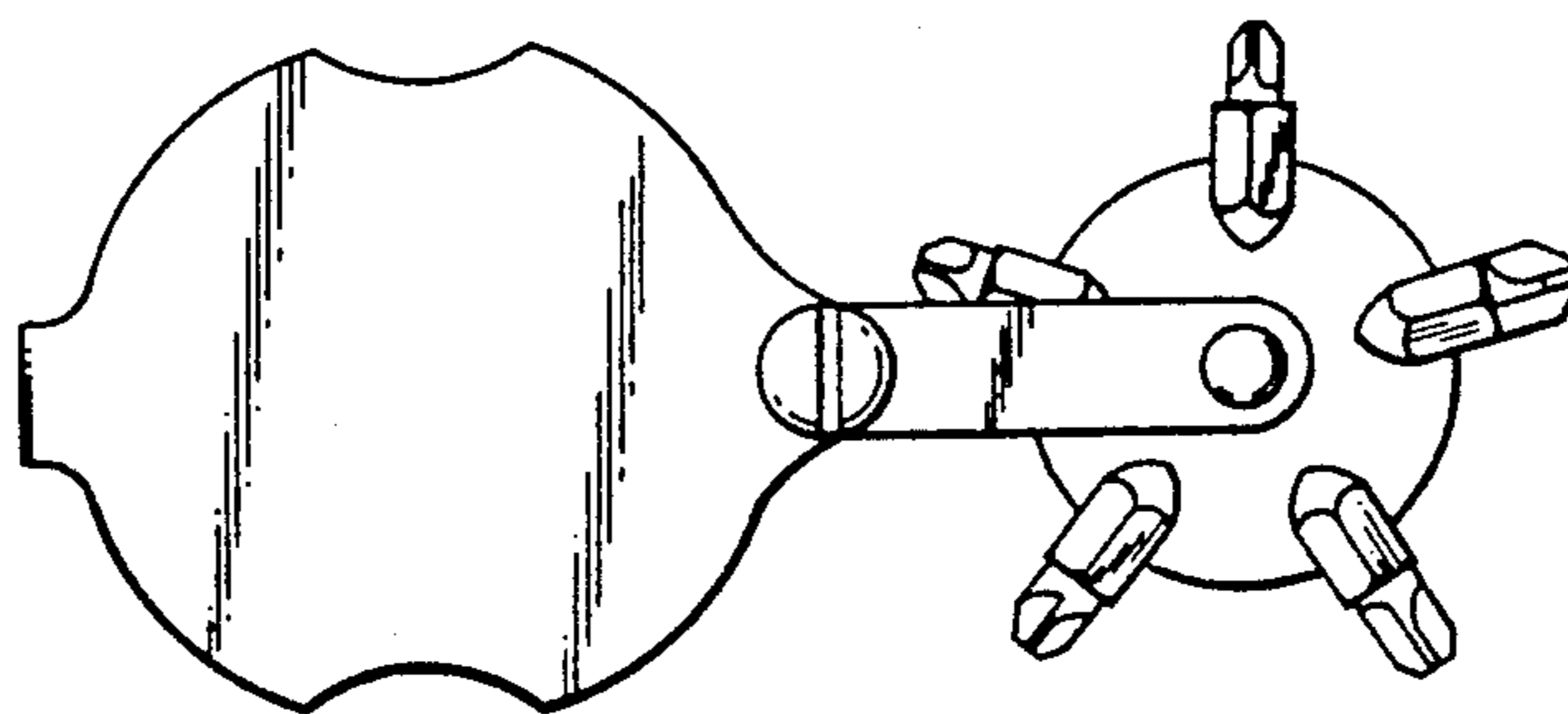

FIG 54