

[54] VEHICLE FOOD TRAY
 [75] Inventor: Patrick G. Forrestal, Kirkwood, Mo.
 [73] Assignee: Glennon and Company, St. Louis, Mo.
 [**] Term: 14 Years
 [21] Appl. No.: 257,023
 [22] Filed: Oct. 12, 1988
 [52] U.S. Cl. D3/40; D3/74
 [58] Field of Search 108/12, 43, 44, 46, 108/45; 211/88, 71, 74; 296/37.1, 37.8, 70; 40/904; D3/40, 74, 73, 99, 35, 39, 30.1; D7/553; D6/572, 574, 466, 535, 469; D28/9; 224/271, 42.11, 42.39, 273, 42.45 R, 42.42, 275, 276, 327, 329, 42; 220/427, DIG. 13; D12/155, 156, 157

D. 307,824 5/1990 Warren D3/40
 2,640,595 6/1953 Byford D3/40 X
 2,695,712 11/1954 Kolander 206/563 X
 2,763,378 9/1956 Black 211/88
 2,770,513 11/1956 Brown 211/88 X
 3,145,848 8/1964 Wood 211/88
 3,151,578 10/1964 Jones 108/46
 3,229,946 1/1966 MacKay 108/46
 3,379,316 4/1968 Harrell D3/40
 3,712,235 1/1973 Russ 224/273 X

Primary Examiner—Louis S. Zarfes
 Assistant Examiner—M. N. Pandozzi
 Attorney, Agent, or Firm—Rogers, Howell & Haferkamp

[56] References Cited
 U.S. PATENT DOCUMENTS

D. 257,914 1/1981 Wooters D7/553 X
 D. 264,525 5/1982 Page, Jr. D3/74 X
 D. 267,061 11/1982 Thompson D6/535
 D. 277,149 1/1985 Hind D6/574
 D. 303,454 9/1989 Morales et al. D3/40

[57] CLAIM
 The ornamental design for a vehicle food tray, as shown and described.

DESCRIPTION
 FIG. 1 is a top plan view of a vehicle food tray showing my new design;
 FIG. 2 is a front elevational view thereof;
 FIG. 3 is a bottom plan view thereof;
 FIG. 4 is a left side elevational view thereof;
 FIG. 5 is a right side elevational view thereof;
 FIG. 6 is a rear elevational view thereof;
 FIG. 7 is a perspective view thereof.

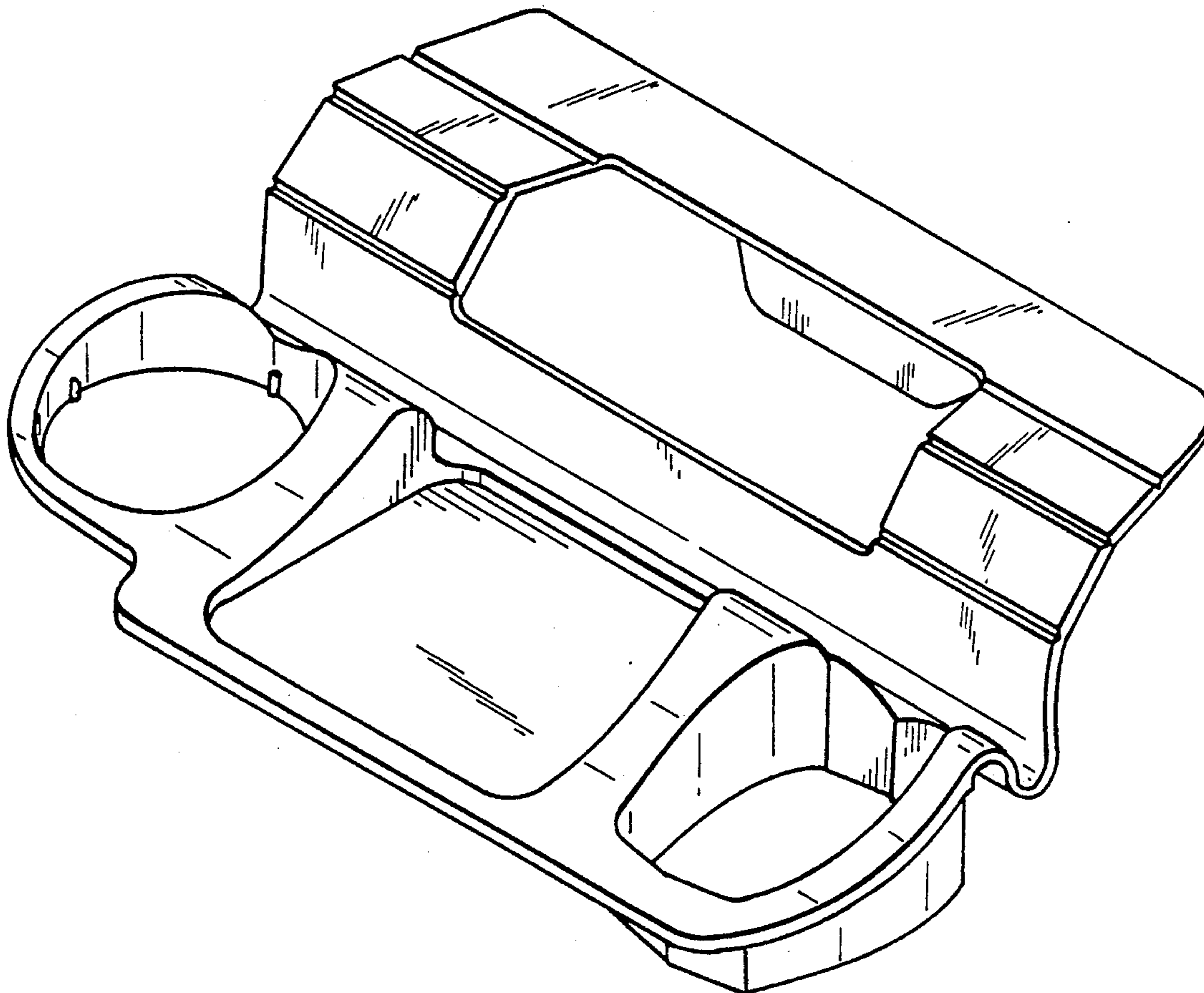

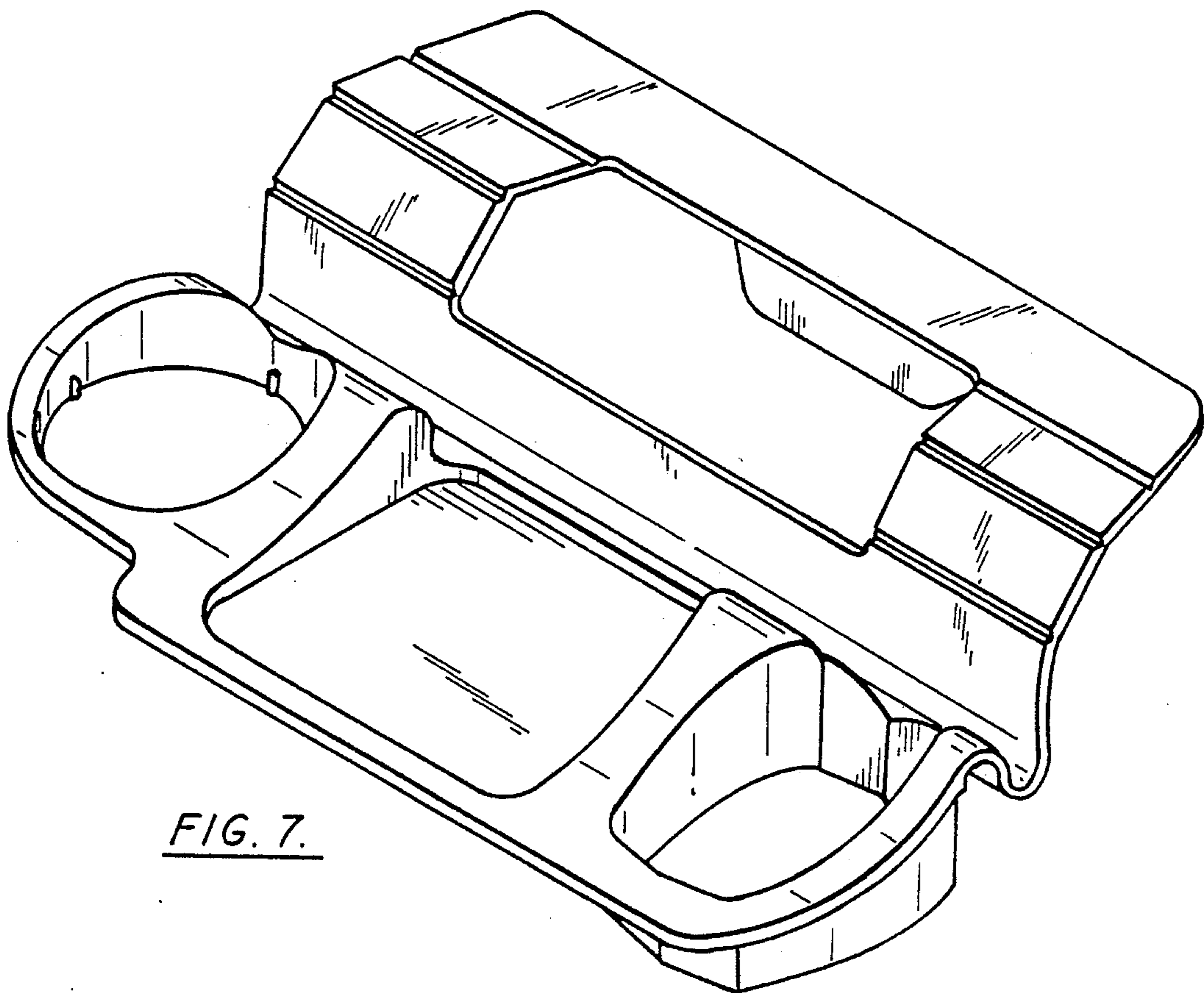
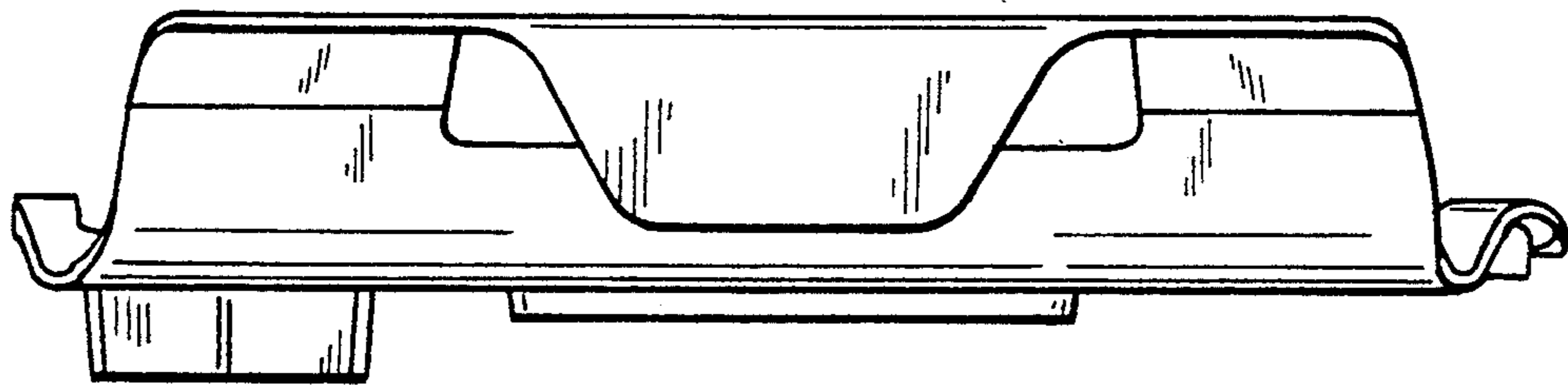
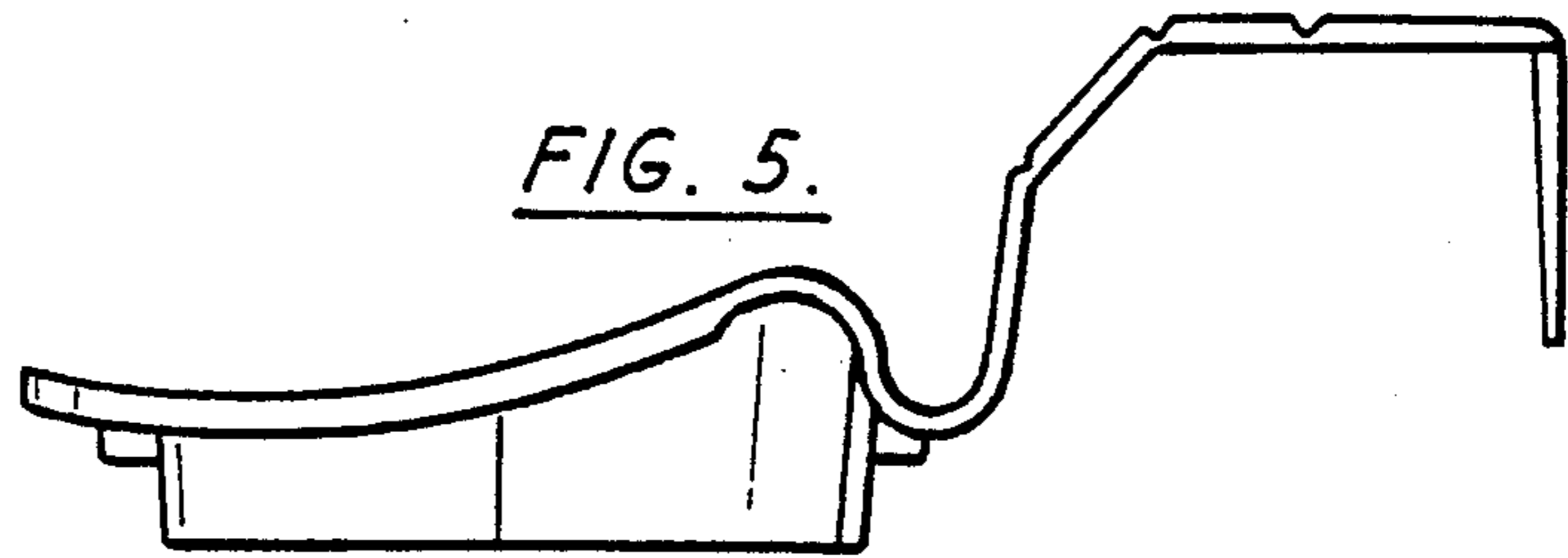
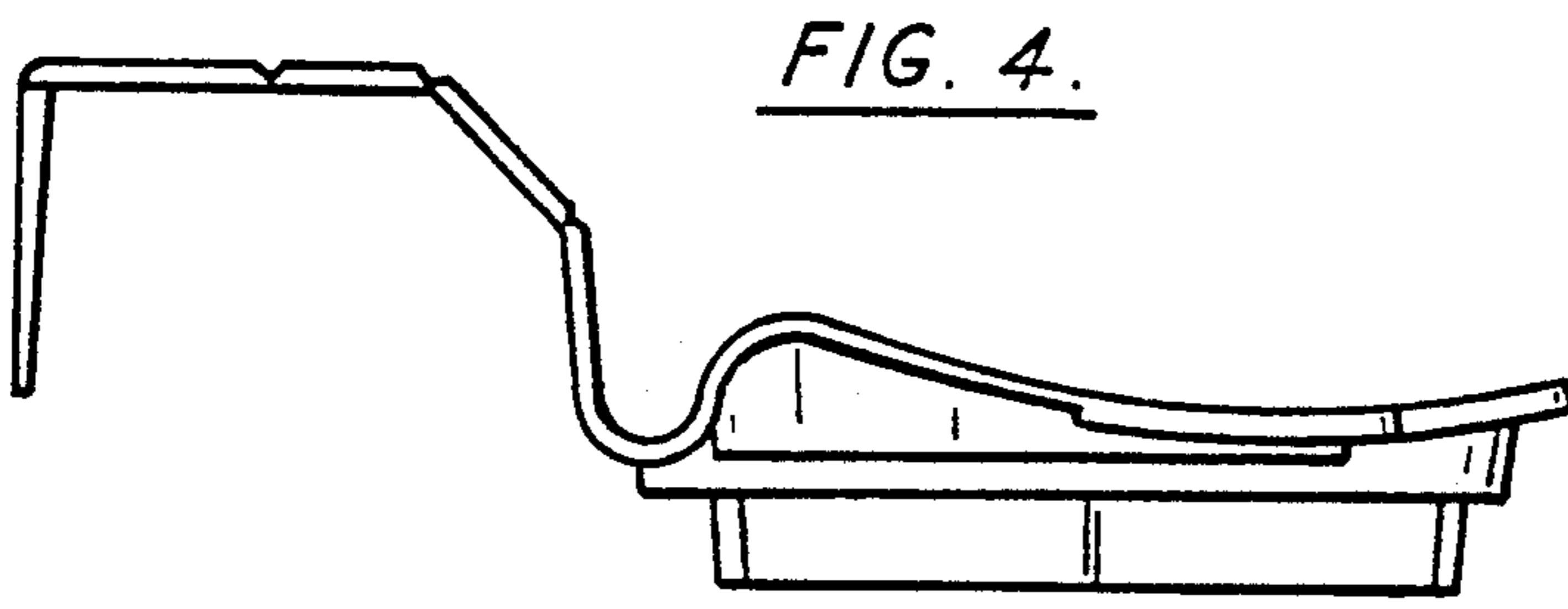

FIG. 1.

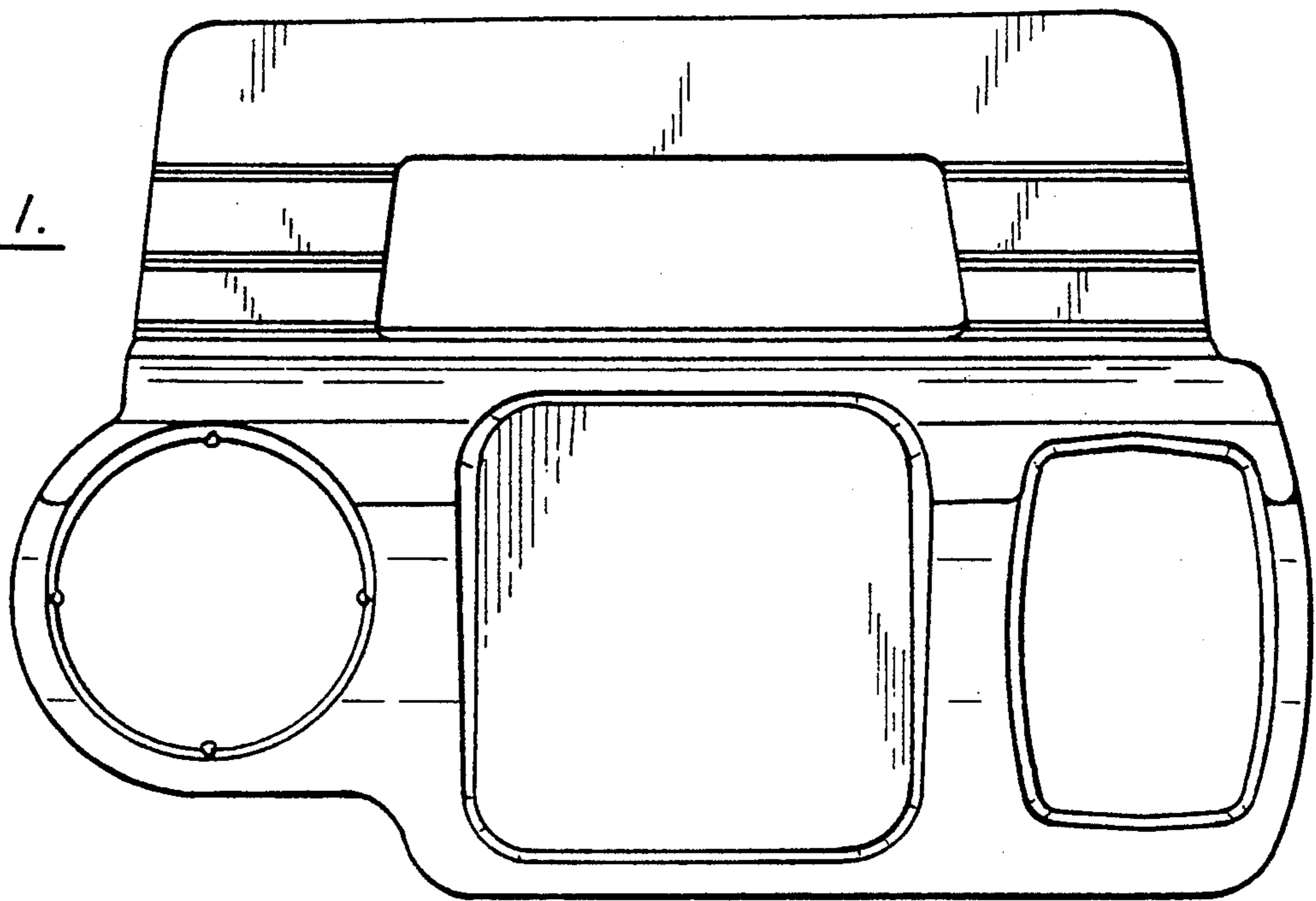

FIG. 2.

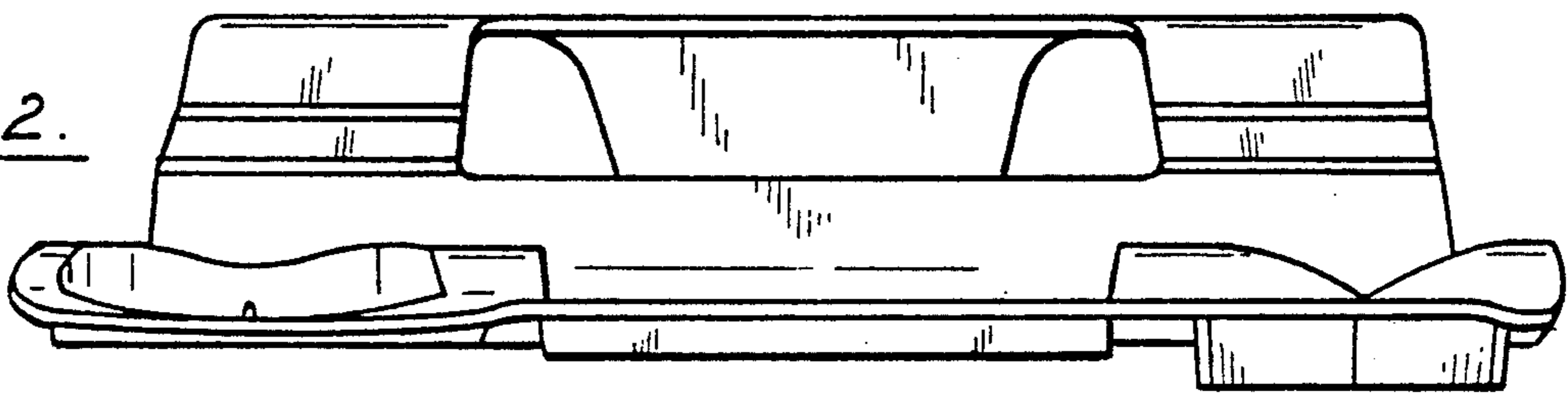

FIG. 3.

