

[54] TOY CAR

[75] Inventor: Hiroyuki Yoshino, Shizuoka, Japan

[73] Assignee: Kabushiki Kaisha Tamiya Mōkei, Shizuoka, Japan

[**] Term: 14 Years

[21] Appl. No.: 430,772

[22] Filed: Nov. 1, 1989

[52] U.S. Cl. D21/137

[58] Field of Search D21/136; 137; D12/88, D12/86; 446/470, 454, 456, 444, 446, 455

[56] References Cited

U.S. PATENT DOCUMENTS

- D. 255,810 7/1980 Bretschger D21/137
- D. 260,913 9/1981 Chapman D12/88
- D. 261,672 11/1981 Phillippe D12/88
- D. 268,940 5/1983 Head D12/88

OTHER PUBLICATIONS

Monogram Catalog 1987, p. 43, #1138 Toy Fair '87. Playthings, Sep. '88, p. 59, "Hurricane".

Hong Kong Toys '88, p. 242, #889.

Hong Kong Toys '88, p. 406, #99.

Hong Kong Toys '88, p. 772, #21568.

Hong Kong Toys '88, p. 86, #16.

Hong Kong Toys '88, p. 242, #3300.

Hong Kong Toys '88, p. 22.

Primary Examiner—Charles A. Rademaker

Assistant Examiner—R. Barkai

Attorney, Agent, or Firm—Finnegan, Henderson, Farabow, Garrett & Dunner

[57] CLAIM

The ornamental design for a toy car, as shown and described.

DESCRIPTION

FIG. 1 is a perspective view of a toy car showing my new design;

FIG. 2 is a front elevational view thereof;

FIG. 3 is a rear elevational view thereof;

FIG. 4 is a top plan view thereof;

FIG. 5 is a bottom plan view thereof;

FIG. 6 is a right side elevational view thereof; and

FIG. 7 is a left side elevational view thereof.

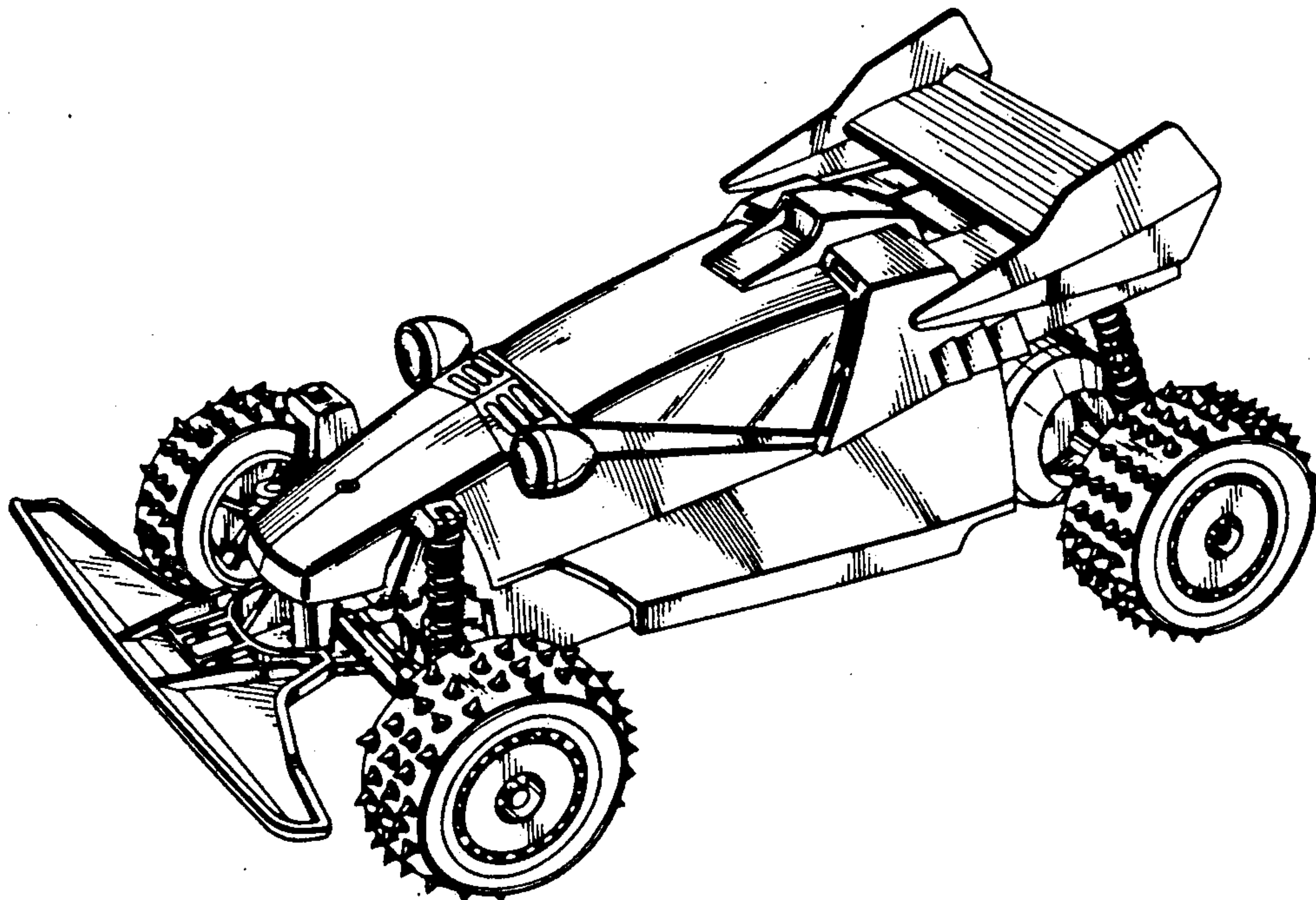

FIG. 1

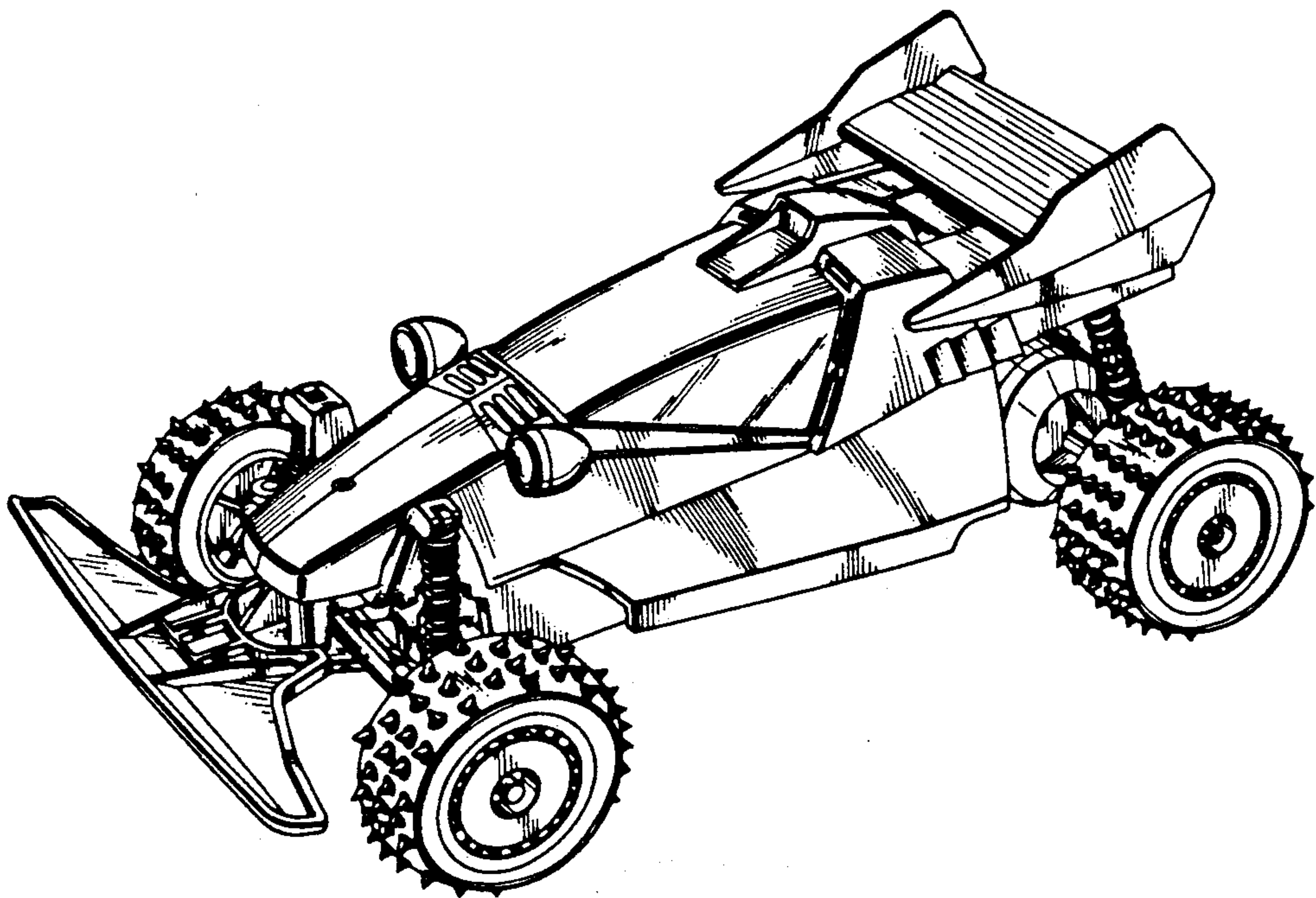

FIG. 2

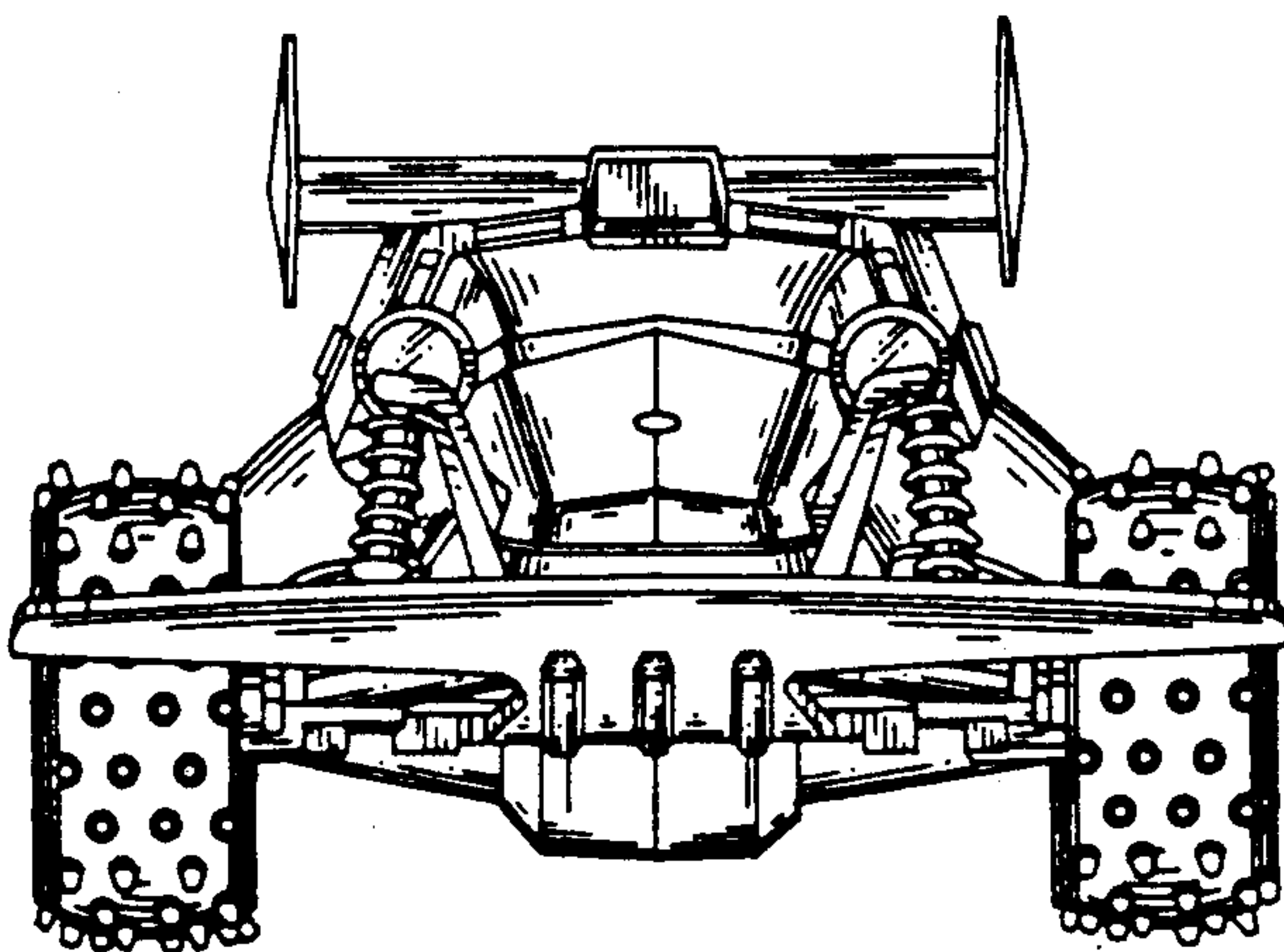

FIG. 3

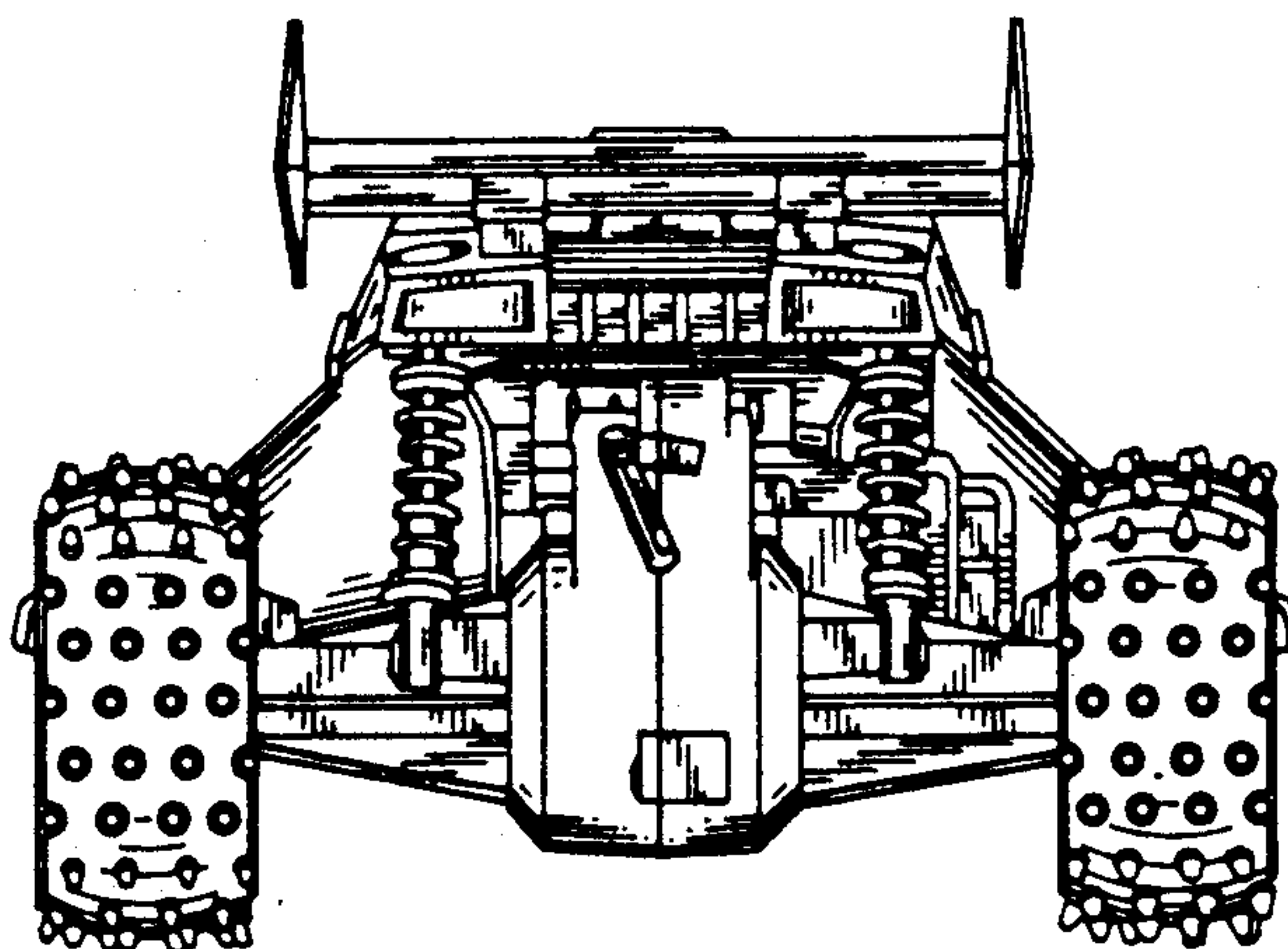

FIG. 4

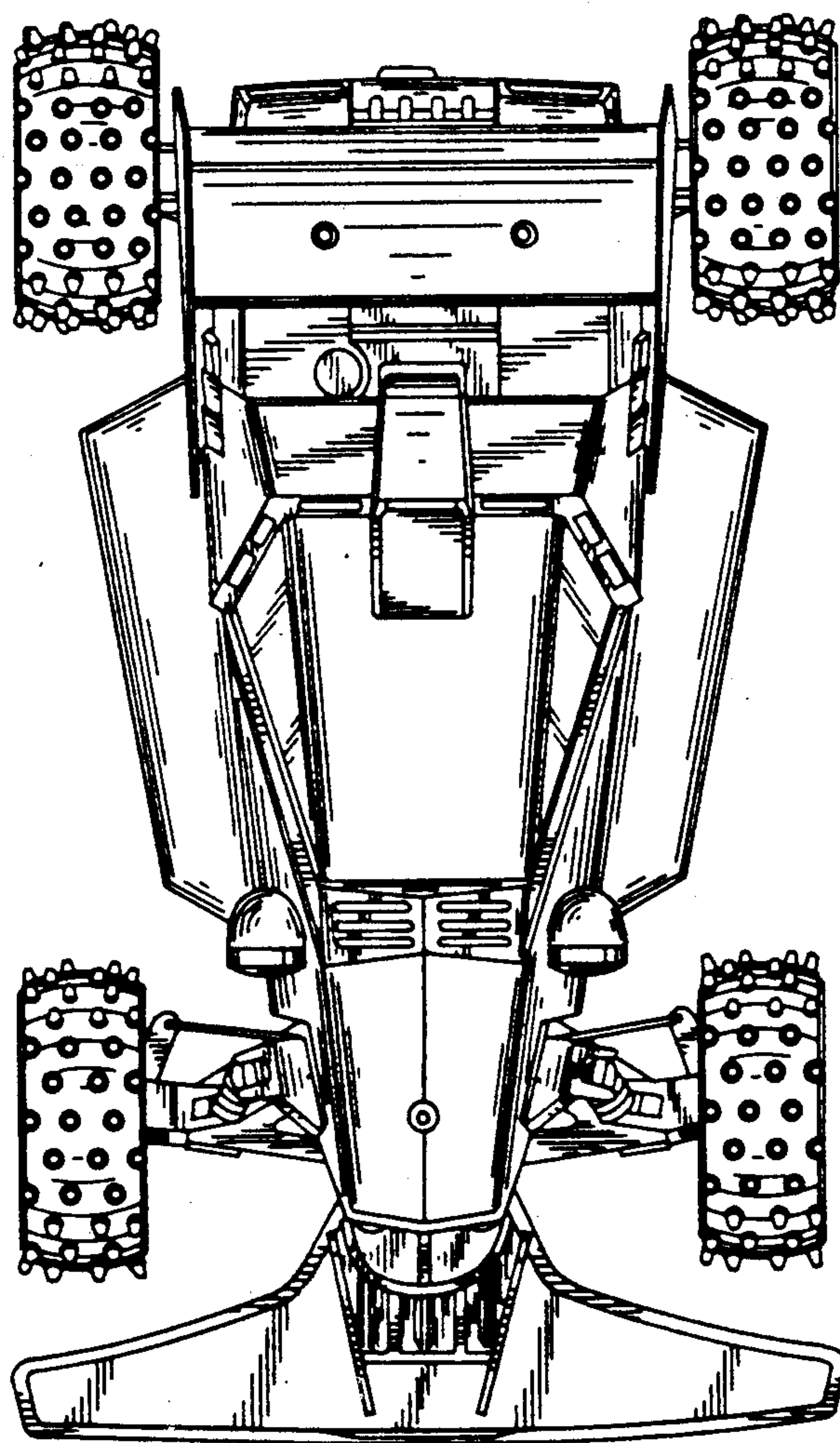

FIG. 5

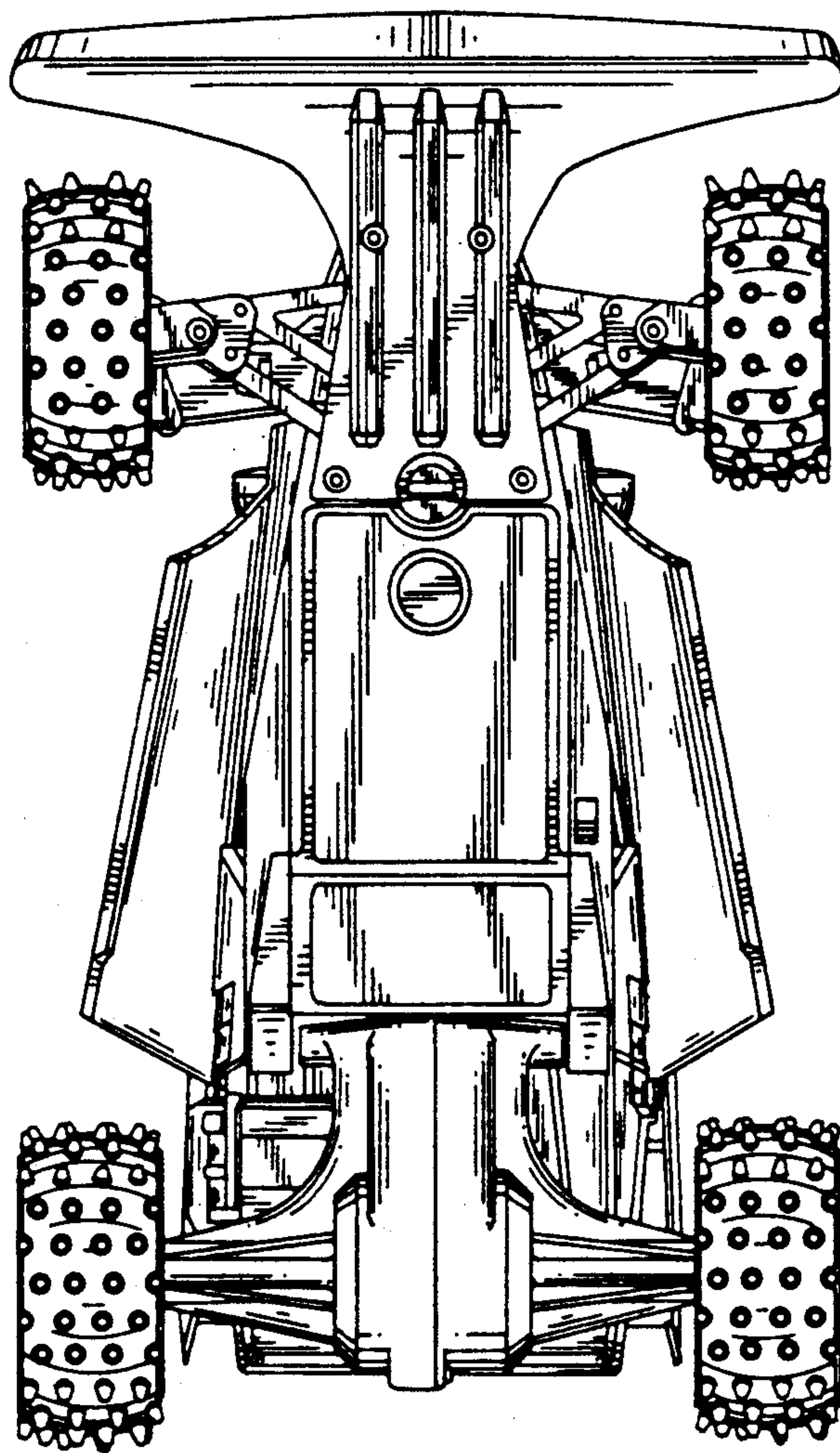

FIG. 6

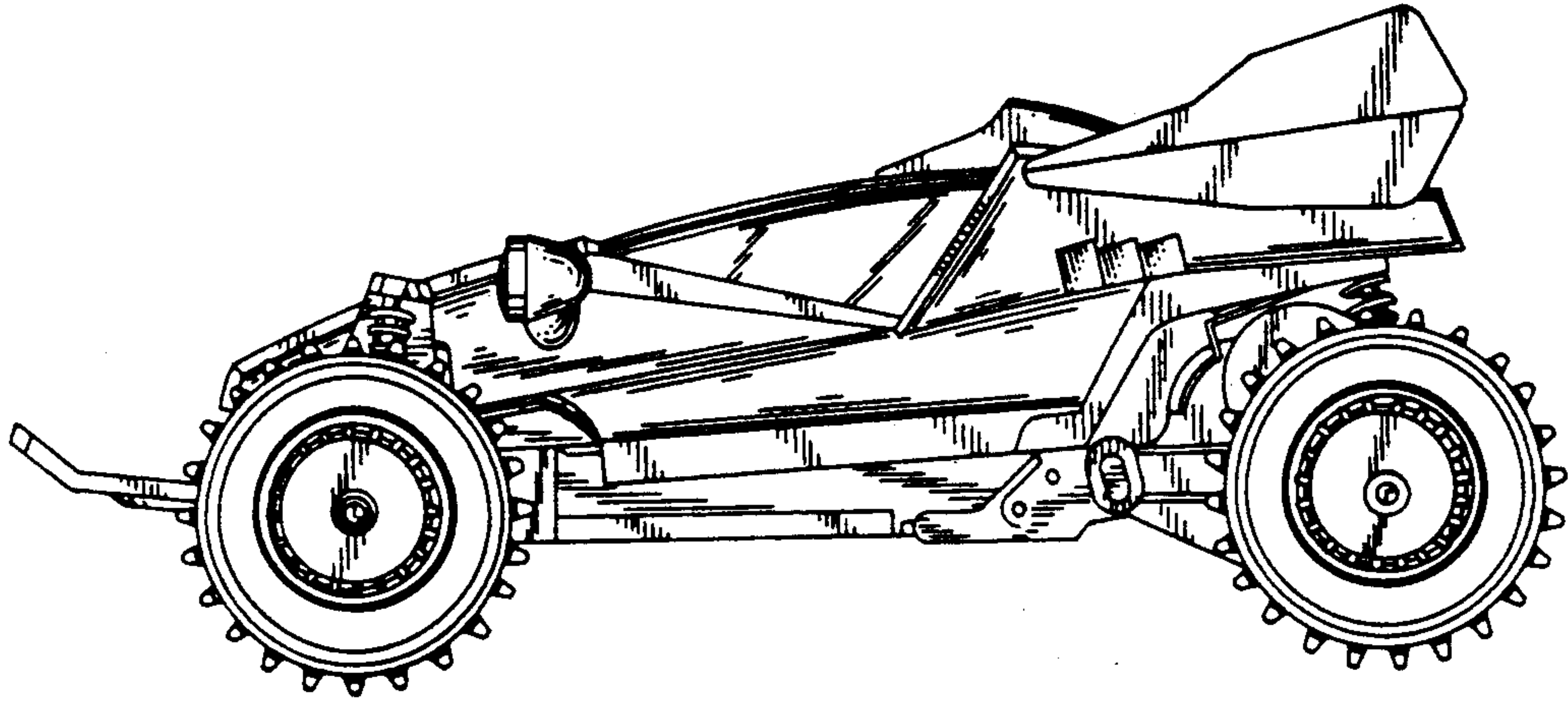

FIG. 7

