

[54] VEHICLE RUNNING BOARD

[75] Inventor: Patrick H. Flores, Oklahoma City, Okla.

[73] Assignee: Macklanburg-Duncan Co., Oklahoma City, Okla.

[\*\*] Term: 14 Years

[21] Appl. No.: 224,550

[22] Filed: Jul. 25, 1988

[52] U.S. Cl. .... D12/203

[58] Field of Search ..... D12/203; D25/62, 68, D25/69; 280/163, 169; 52/177, 179

[56] References Cited

U.S. PATENT DOCUMENTS

D. 257,532 11/1980 Okland ..... D12/203  
4,456,275 6/1984 Snyder et al. .... 280/163

Primary Examiner—James M. Gandy  
Attorney, Agent, or Firm—Laney, Dougherty, Hessin & Beavers

[57] CLAIM

The ornamental design for a vehicle running board, as shown and described.

DESCRIPTION

FIG. 1 is a perspective view of a vehicle running board showing my new design;  
FIG. 2 is a rear end elevation view thereof;  
FIG. 3 is a front end elevation view thereof;  
FIG. 4 is a top plan view thereof;  
FIG. 5 is a bottom plan view thereof;  
FIG. 6 is a side elevation view thereof; and  
FIG. 7 is an opposite side elevation view thereof.  
The vehicle running board has been broken away in the middle in FIGS. 4, 5, 6 and 7 for convenience of illustration.

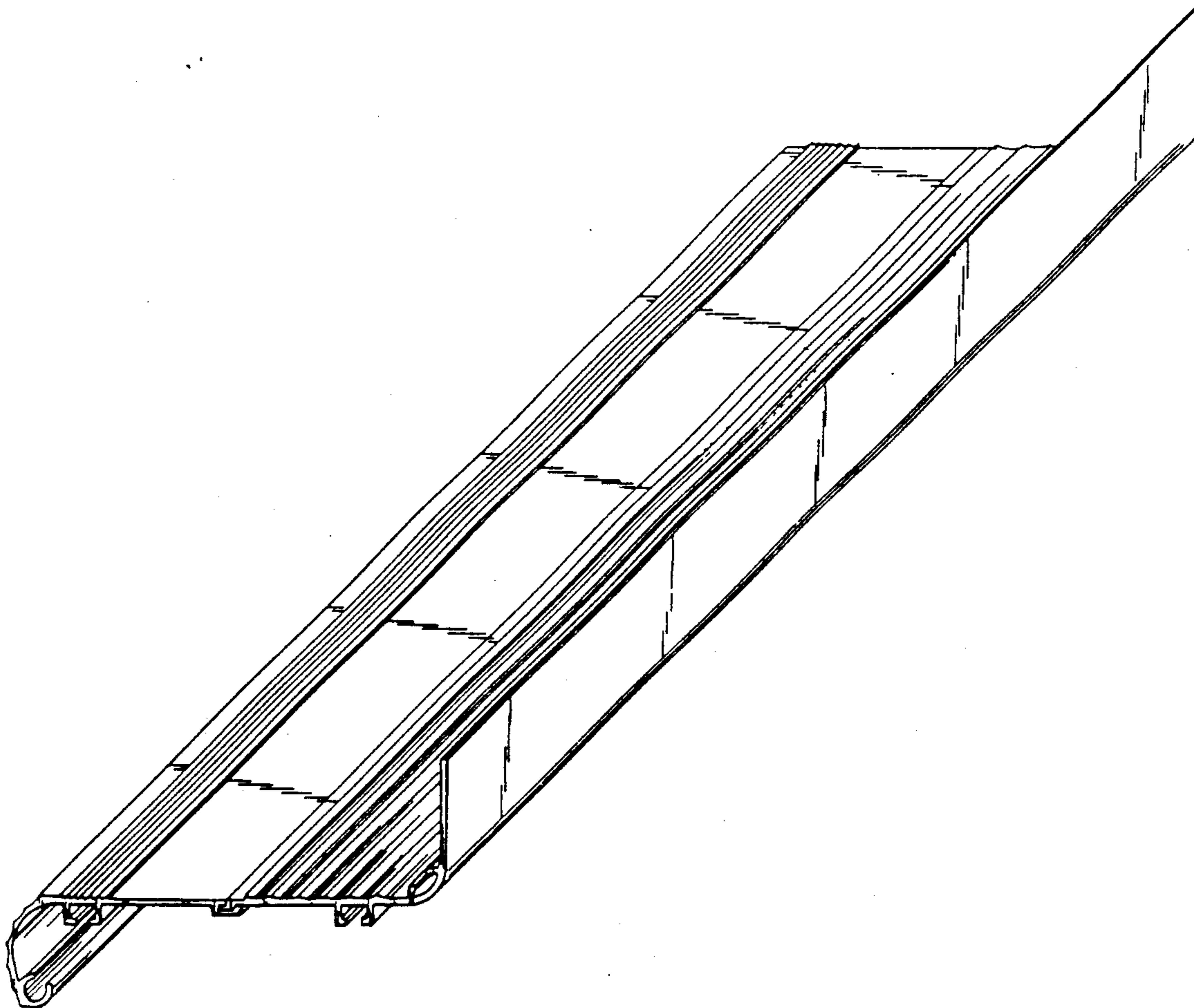

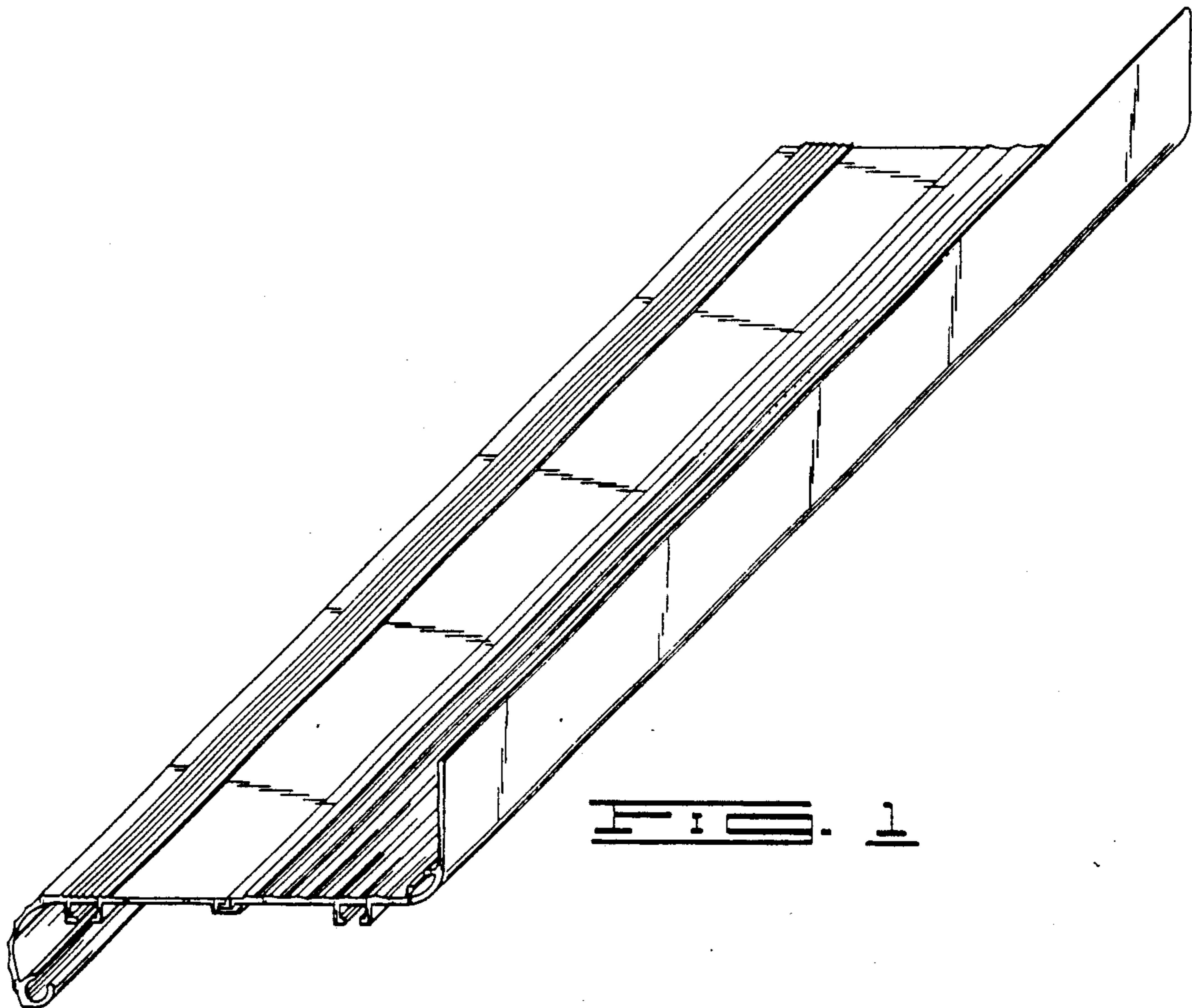

FIG. 1

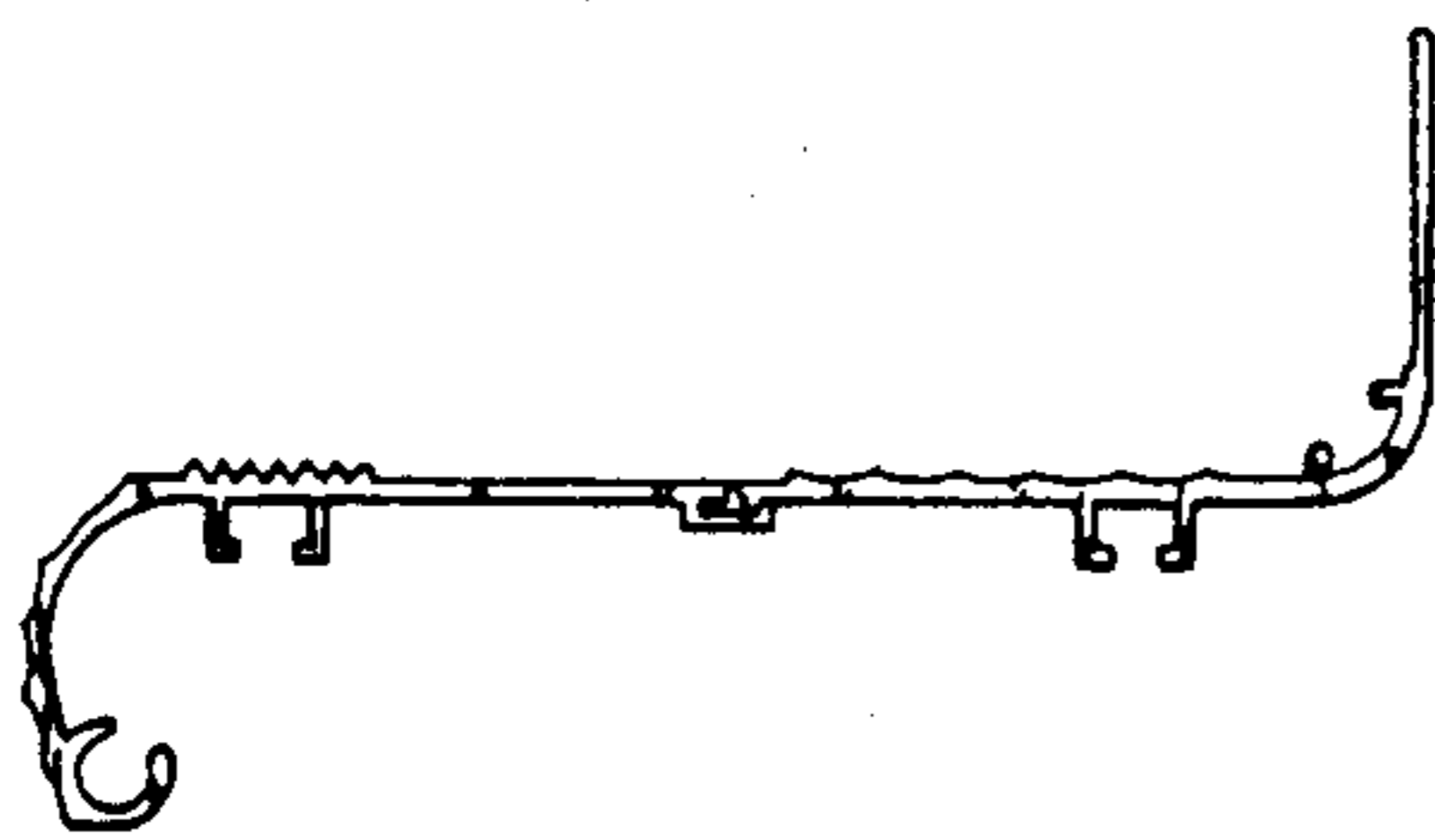

FIG. 2

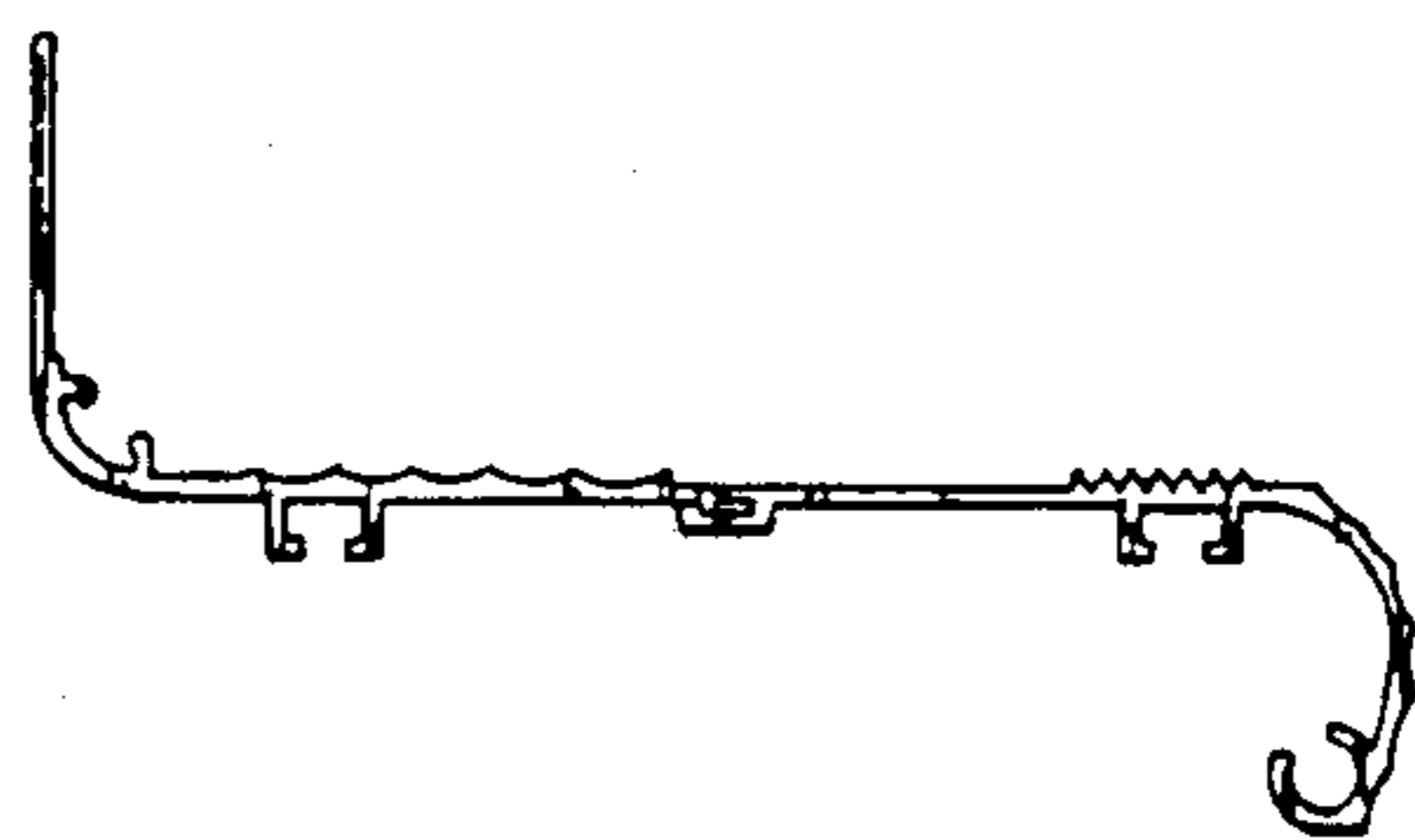

FIG. 3

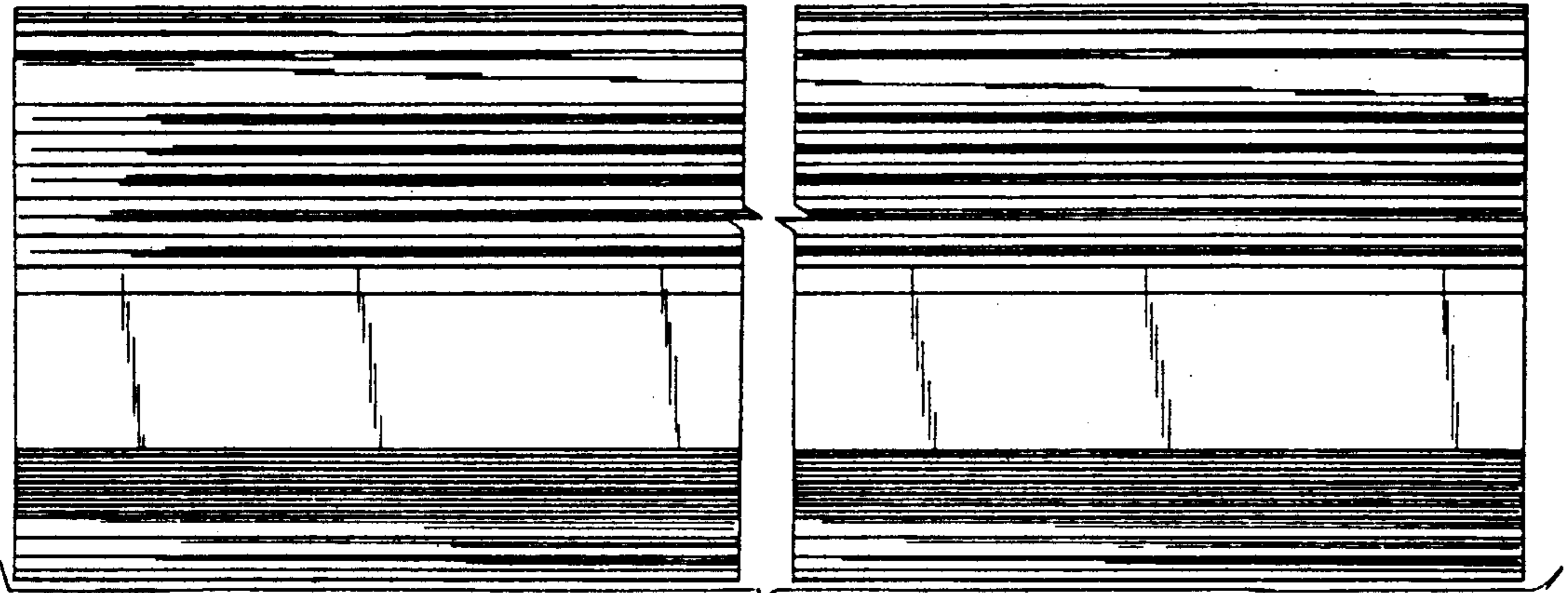

FIG. 4

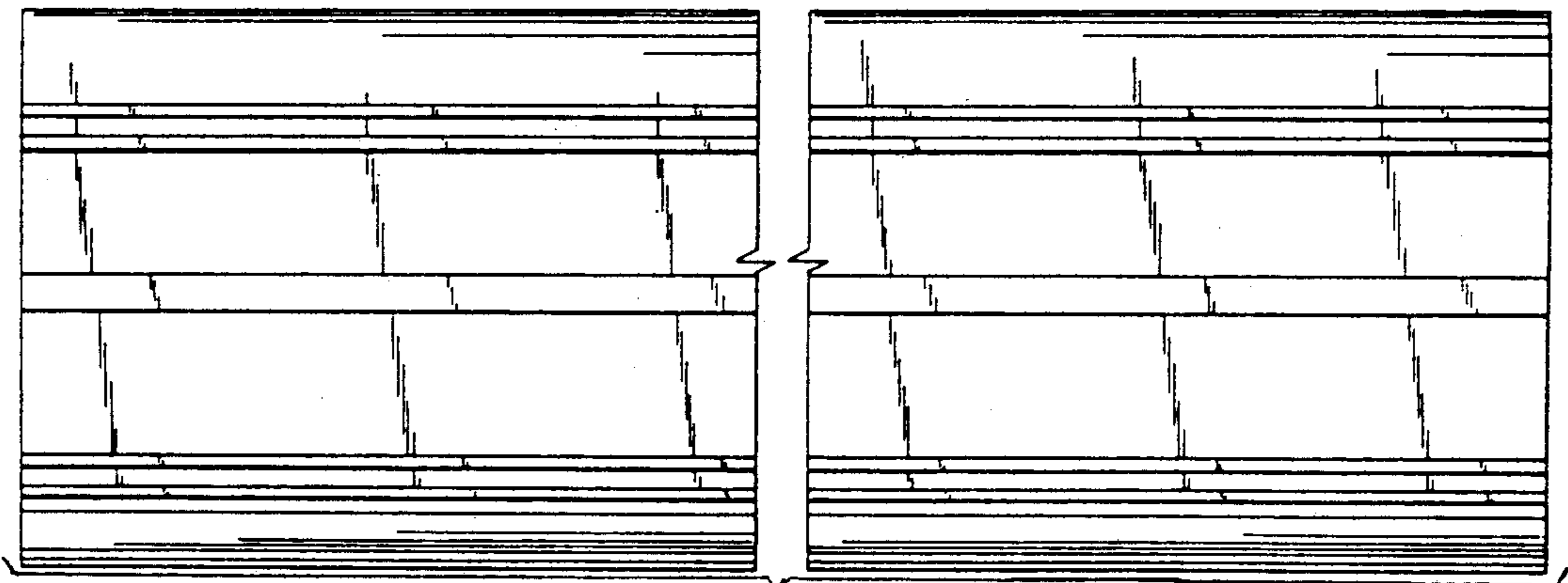

FIG. 5

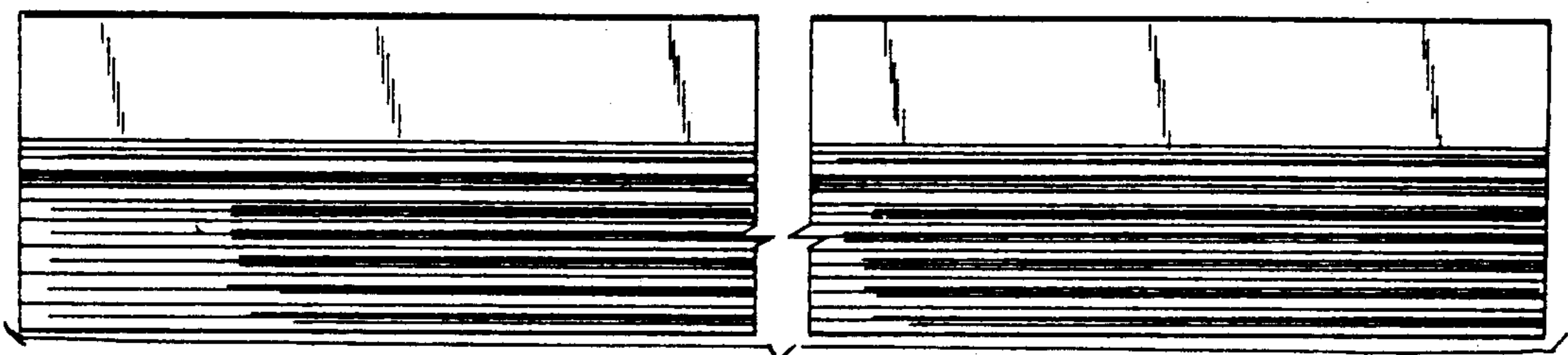

FIG. 6

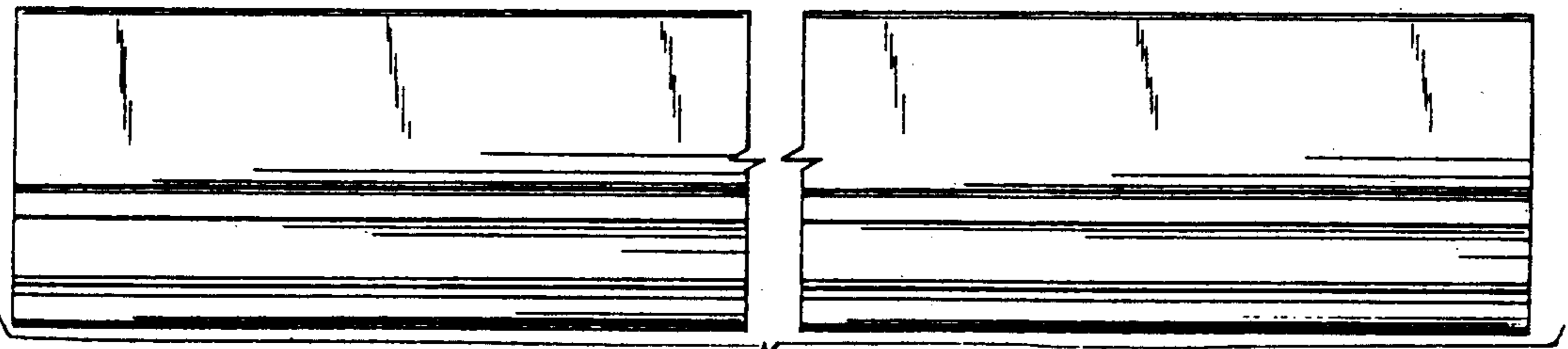

FIG. 7