

[54] **ARTICLE CARRIER STANCHION**

[76] Inventor: **John A. Bott**, 931 Lakeshore Dr.,
Grosse Pointe Shores, Mich. 48236

[**] Term: **14 Years**

[21] Appl. No.: **282,285**

[22] Filed: **Dec. 9, 1988**

[52] U.S. Cl. **D12/157**

[58] Field of Search **D12/157; 224/309, 317,
224/321, 322, 324, 325, 326, 327**

4,516,710 5/1985 Bott 224/324
 4,684,048 8/1987 Bott 224/326
 4,754,905 7/1988 Bott 224/316
 4,767,041 8/1988 Stapleton 224/309
 4,834,448 5/1989 Sakamoto et al. 224/309

Primary Examiner—James M. Gandy
Assistant Examiner—Melody N. Brown
Attorney, Agent, or Firm—Harness, Dickey & Pierce

[57] **CLAIM**

The ornamental design for an article carrier stanchion, as shown and described.

[56] **References Cited**
U.S. PATENT DOCUMENTS

| | | | | |
|------------|---------|-----------------|-------|------------|
| D. 297,628 | 9/1988 | Robson | | D12/157 |
| 4,099,658 | 7/1978 | Bott | | 224/42.1 F |
| 4,133,465 | 1/1979 | Bott | | 224/42.1 D |
| 4,162,755 | 7/1979 | Bott | | 224/326 |
| 4,182,471 | 1/1980 | Bott | | 224/326 |
| 4,274,570 | 6/1981 | Bott | | 224/324 |
| 4,295,587 | 10/1981 | Bott | | 224/321 |
| 4,323,182 | 4/1982 | Bott | | 224/321 |
| 4,341,332 | 7/1982 | Kowalski et al. | | 224/309 |
| 4,364,500 | 12/1982 | Bott | | 224/325 |
| 4,431,123 | 2/1984 | Bott | | 224/321 |
| 4,473,178 | 9/1984 | Bott | | 224/324 |

DESCRIPTION

FIG. 1 is a perspective view of an article carrier stanchion showing my new design, it being understood that the broken lines are for illustrative purposes only and form no part of the claimed design;
 FIG. 2 is a top plan view thereof;
 FIG. 3 is a side elevational view thereof taken in the direction of the arrow 3 in FIG. 2; it being understood that the opposite side is a mirror image of that shown;
 FIG. 4 is an end elevational view thereof taken in the direction of the arrow 4 in FIG. 2; and
 FIG. 5 is an end elevational view thereof opposite to that shown in FIG. 4.

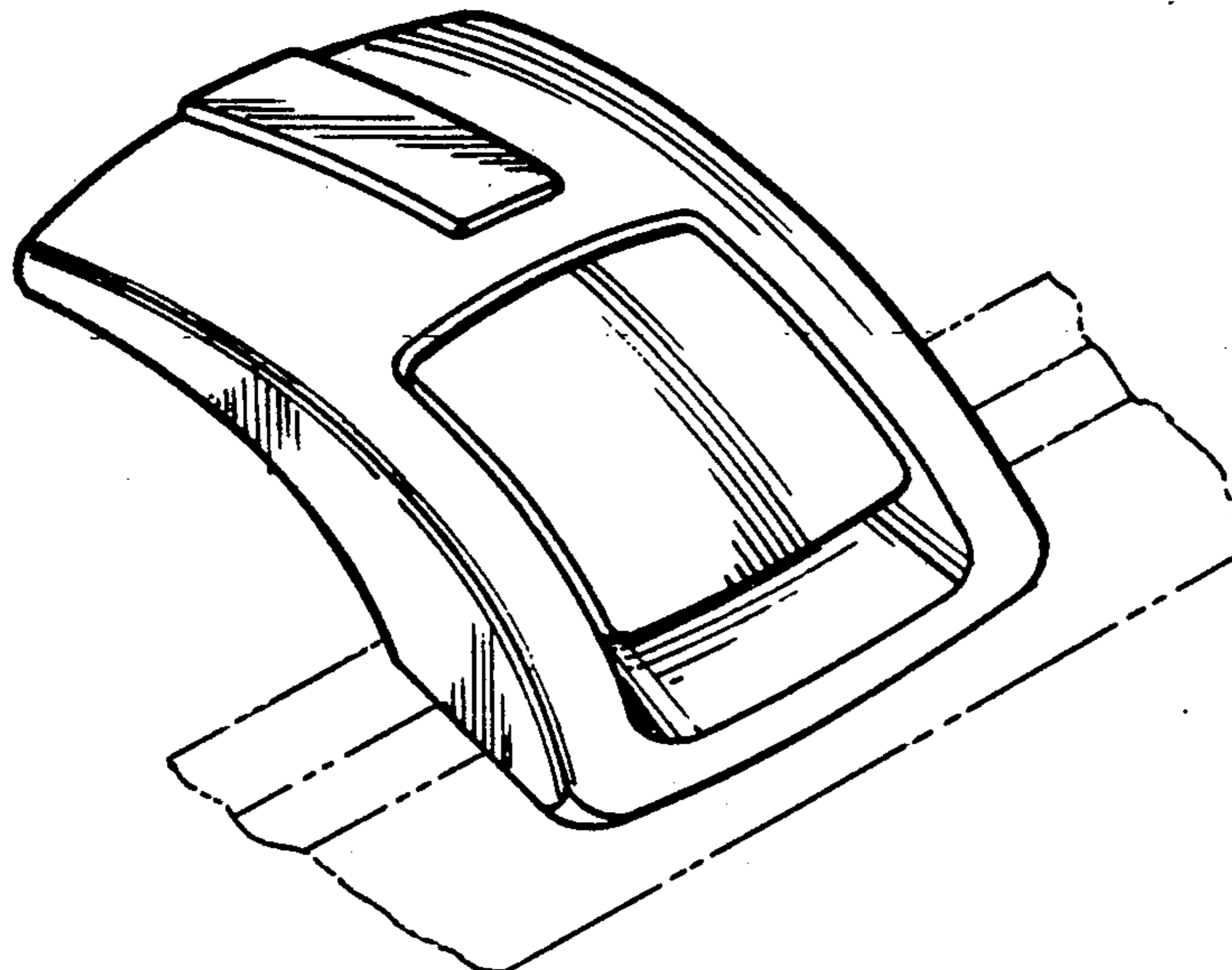

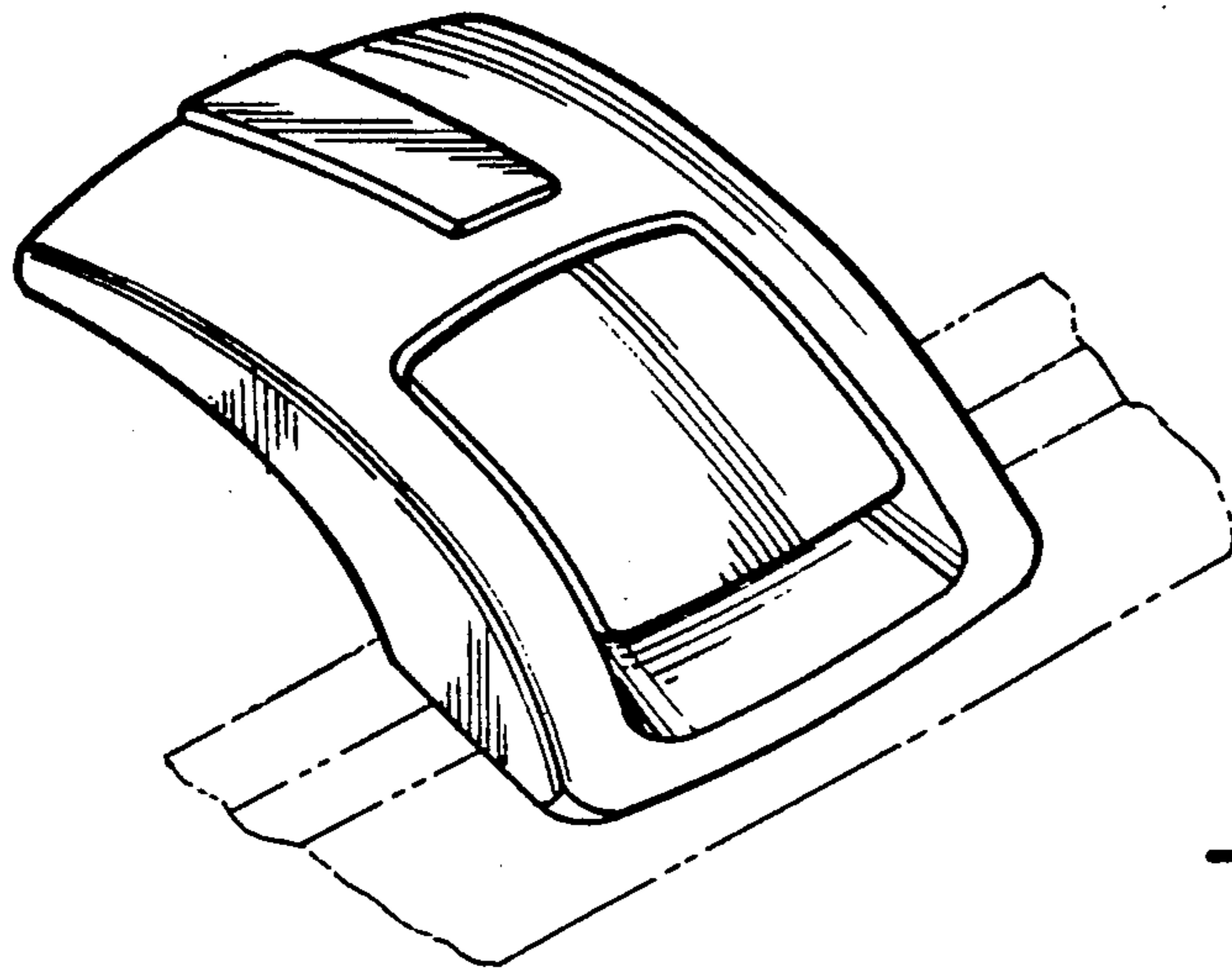

Fig-1

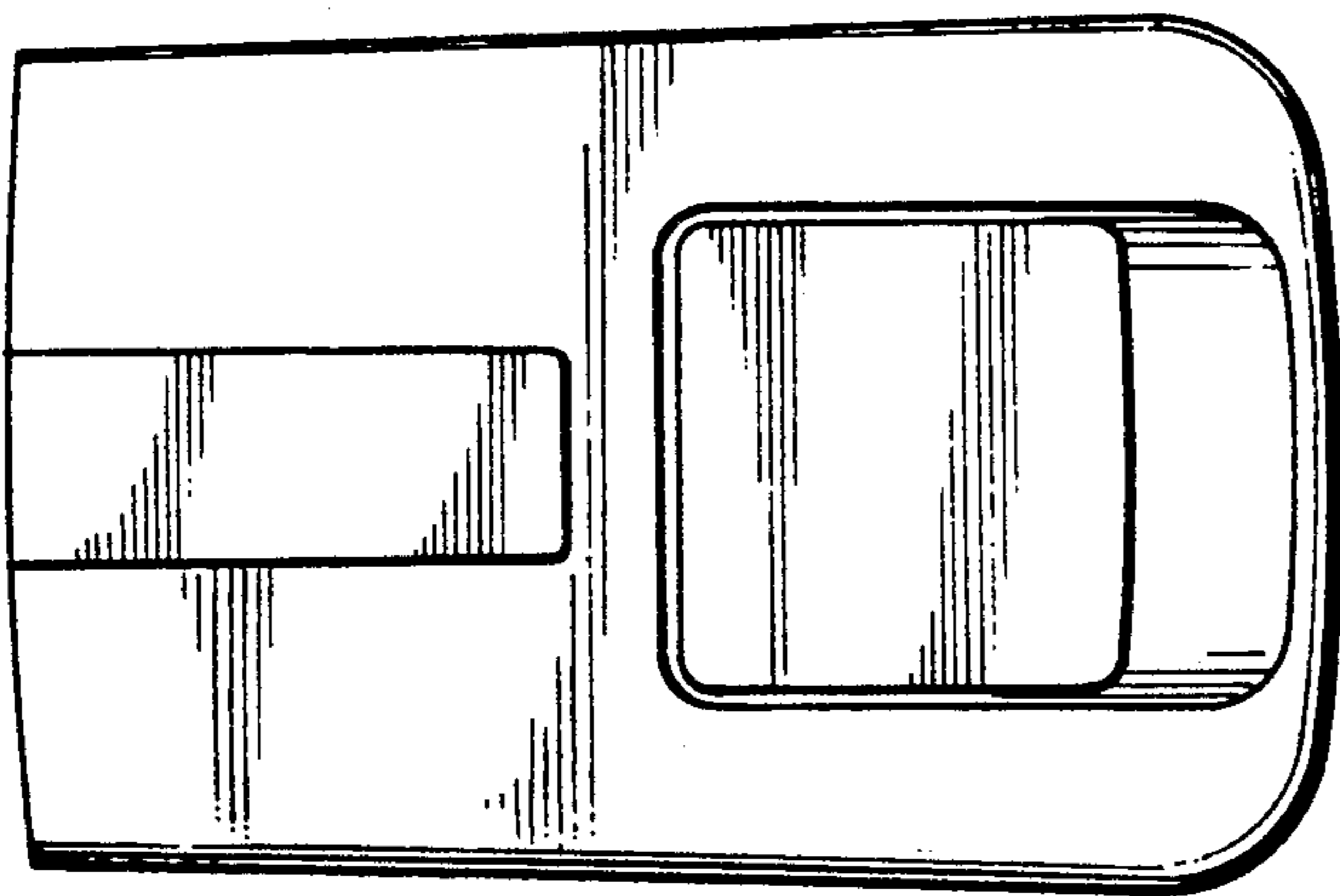

Fig-2

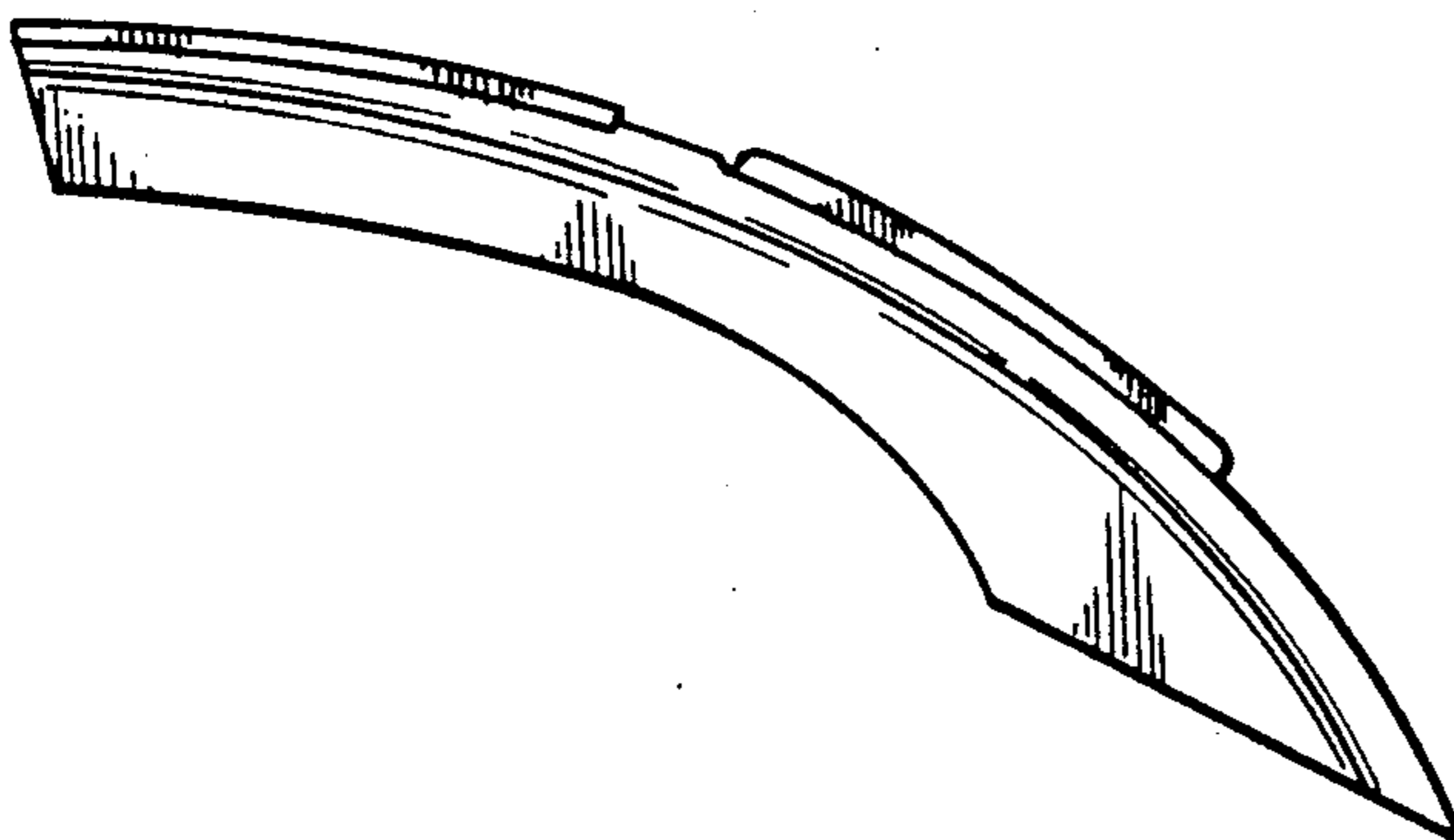

Fig-3

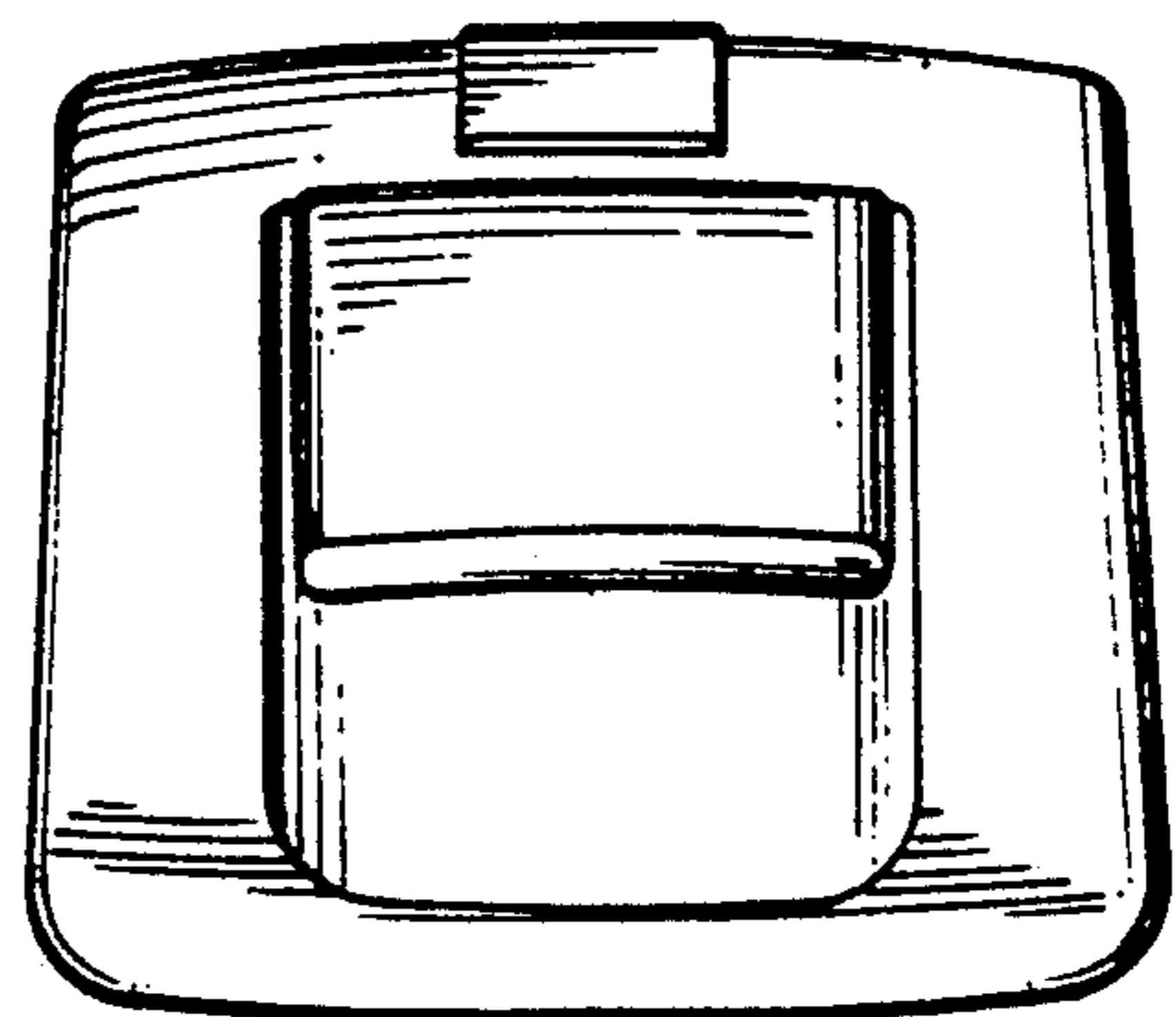

Fig-4

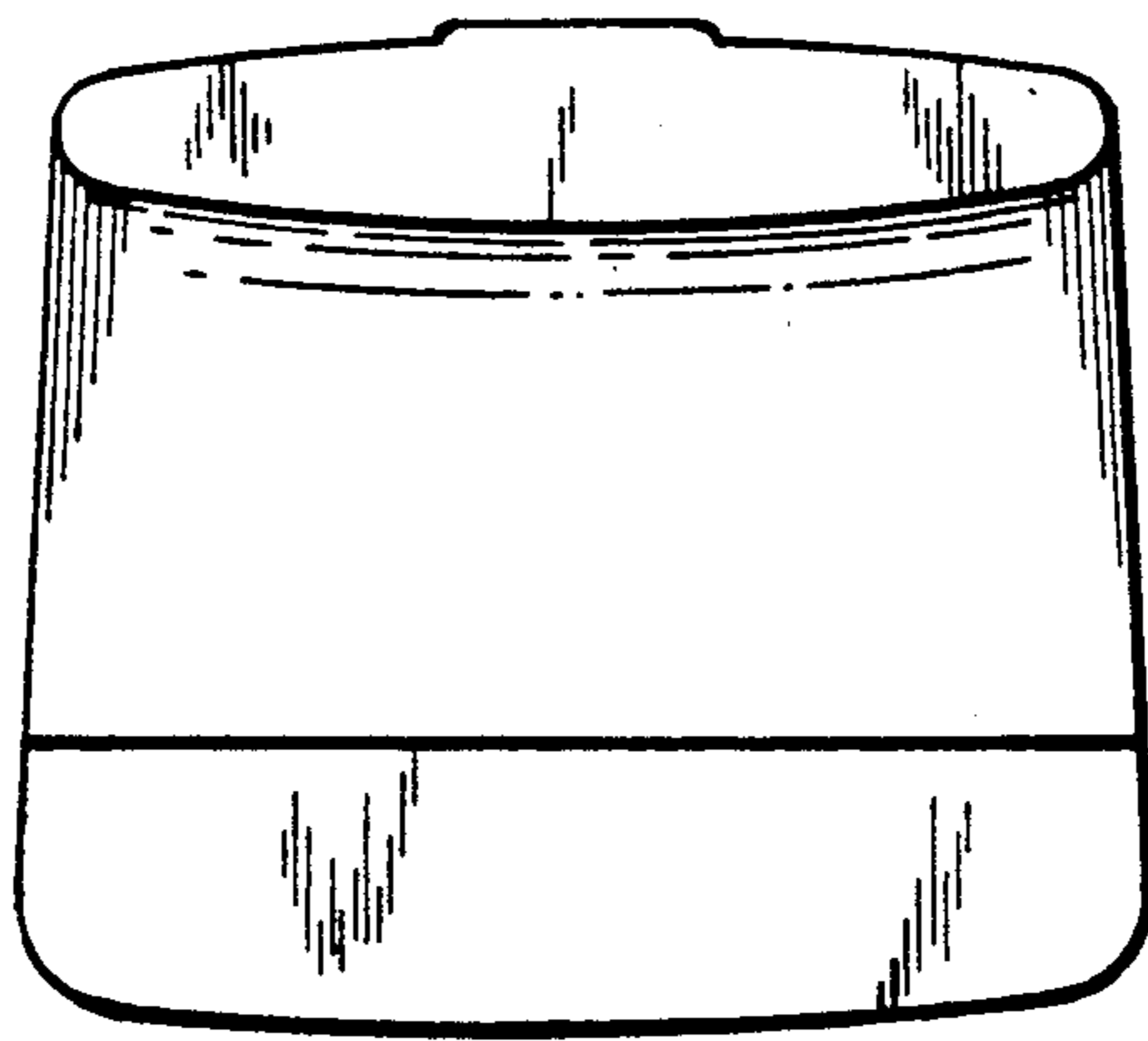

Fig-5