

[54] **VEHICLE ATTACHED ARTICLE CARRIER FOR LUMBER OR THE LIKE**

[75] **Inventor: Kevin W. Miller, Southfield, Mich.**

[73] **Assignee: Jupiter Products, Inc., Centerline, Mich.**

[**] **Term: 14 Years**

[21] **Appl. No.: 372,302**

[22] **Filed: Jun. 26, 1989**

[52] **U.S. Cl. D12/157; D8/370; D8/380; D8/373; D8/367; 224/42.45 R**

[58] **Field of Search D8/370, 380; 248/303, 248/304, 340, 339, 544, 371; 224/42, 42.5 R, 42.46 R, 42.42; D6/552, 512; D12/115, 157; D34/5**

[56] **References Cited**

U.S. PATENT DOCUMENTS

D. 245,892	9/1977	Yocum	D6/552
D. 248,809	8/1978	Kailey	D6/552
D. 282,801	3/1986	Goins	D6/512 X
D. 300,804	4/1989	Myers	D8/370 X
252,381	1/1882	Hybre .	
1,220,717	3/1971	Bennett	248/303 X
1,919,271	7/1933	Cady .	
2,036,010	3/1936	Atkins	D14/253
2,302,300	11/1942	Davies .	
2,425,629	8/1947	Mayer .	
3,195,731	7/1965	Bomar, Jr.	248/303 X
3,578,282	6/1971	Olsen	248/214

4,108,342	8/1978	Riva	224/42.46 R
4,458,873	7/1984	Sutherland	248/544
4,582,015	4/1986	Hunter .	
4,596,348	6/1986	Stamp .	
4,607,773	8/1986	Mason	224/42.45 R
4,915,248	4/1990	Chap	D34/5 X
4,942,989	7/1990	Miller	224/42.46 R

FOREIGN PATENT DOCUMENTS

2043004A 10/1980 United Kingdom .

Primary Examiner—Horace B. Fay, Jr.

Attorney, Agent, or Firm—Harness, Dickey & Pierce

[57] **CLAIM**

The ornamental design for a vehicle attached article carrier for lumber or the like, as shown and described.

DESCRIPTION

FIG. 1 is a perspective view of a vehicle attached carrier for lumber, or the like, showing my new design positioned along with a second carrier mounted upon the side of a vehicle, with the carriers supporting elongated articles, and with the second carrier, vehicle portion and boards shown in broken lines for illustrative purposes only, and forming no part of the claimed design;

FIG. 2 is a right side elevational view thereof;

FIGS. 3 and 4 are respectively top and bottom plan views thereof; and

FIGS. 5 and 6 being are respectively front and rear elevational view thereof.

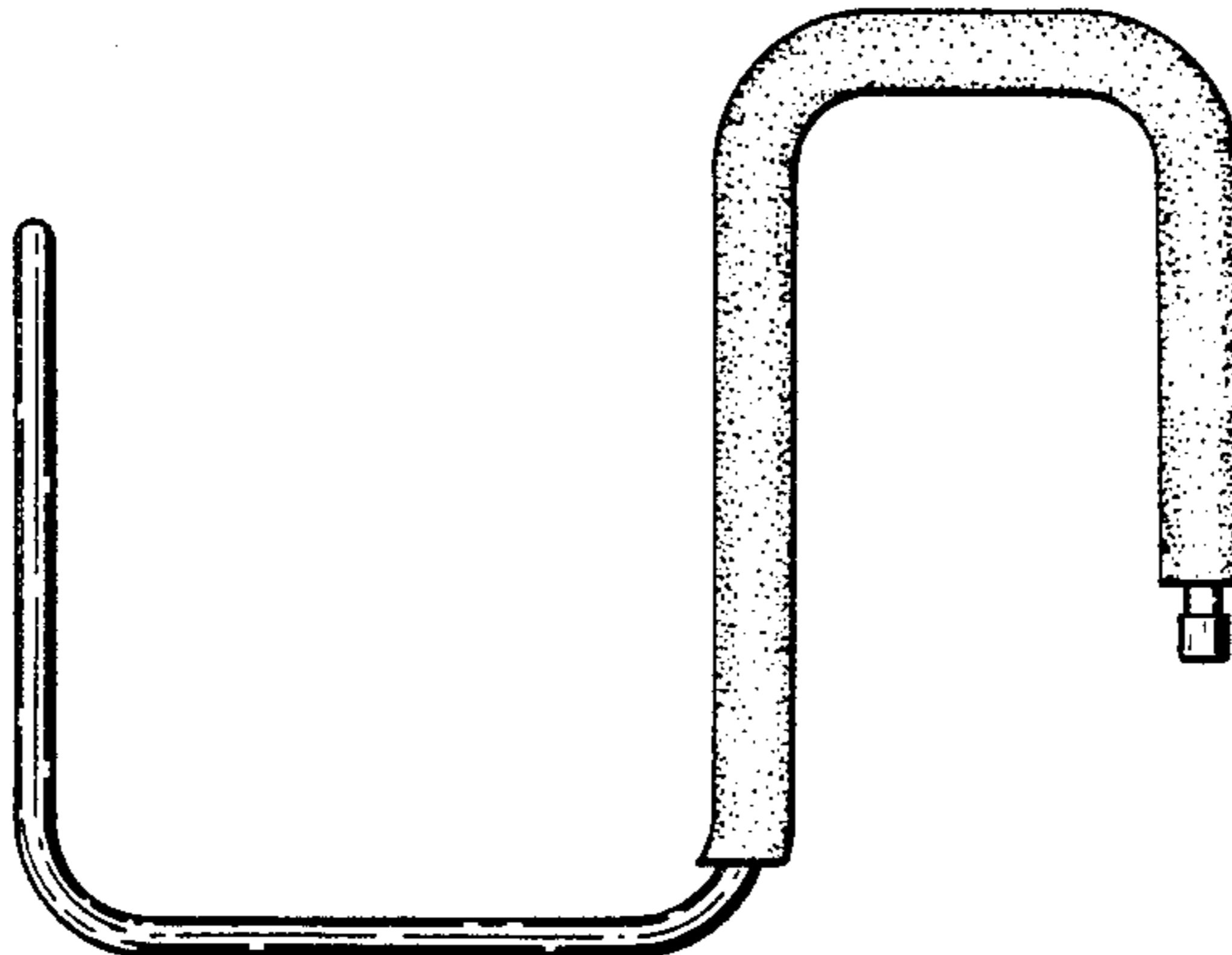
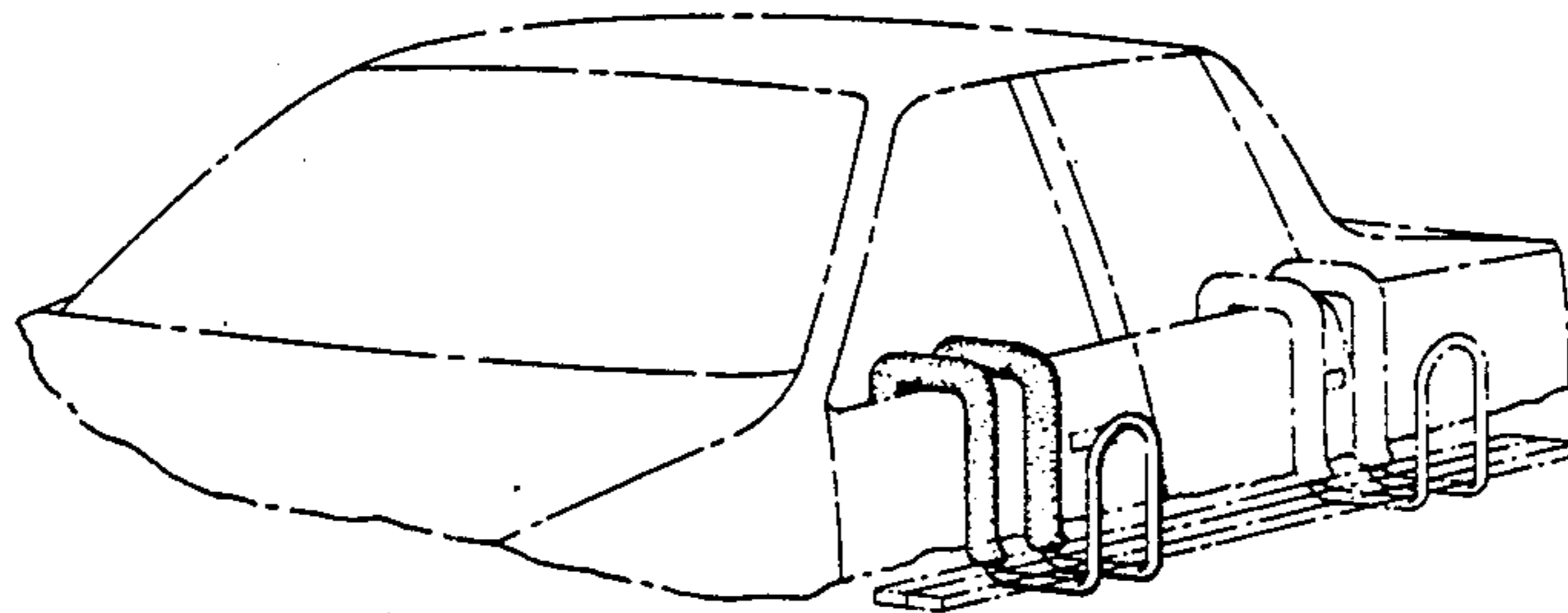

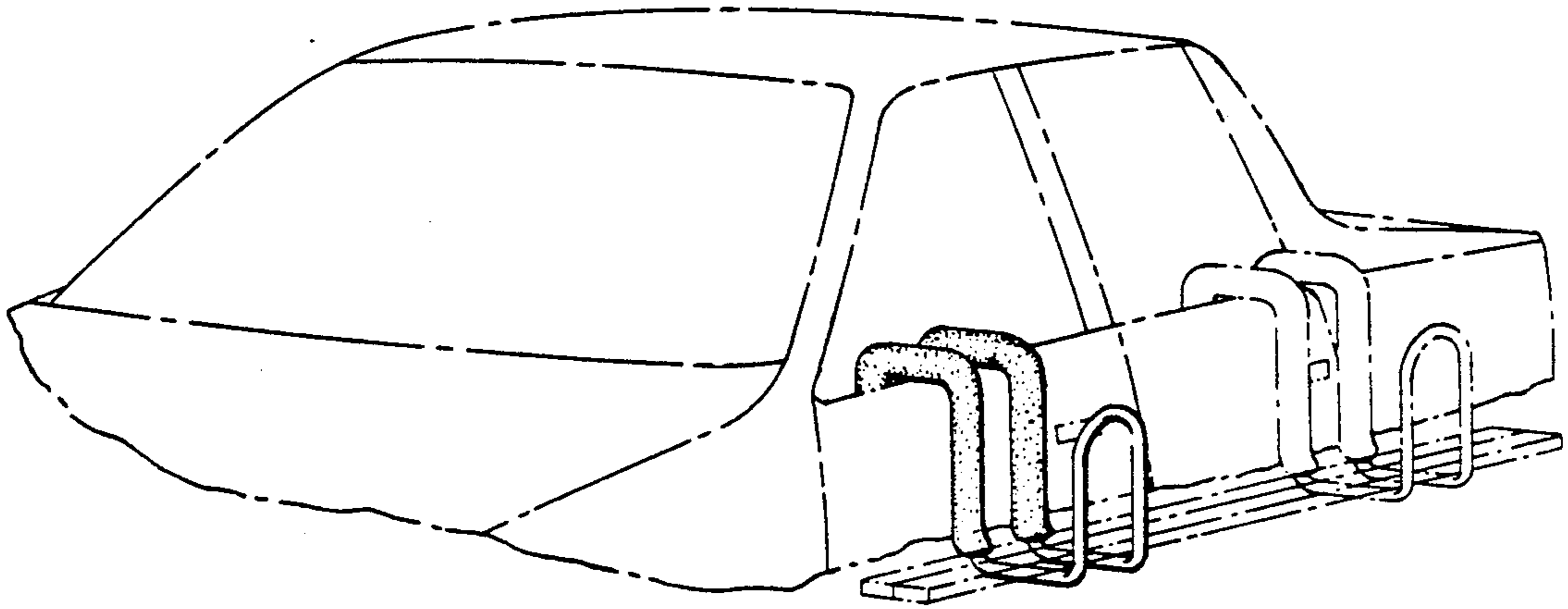

FIG. 1.

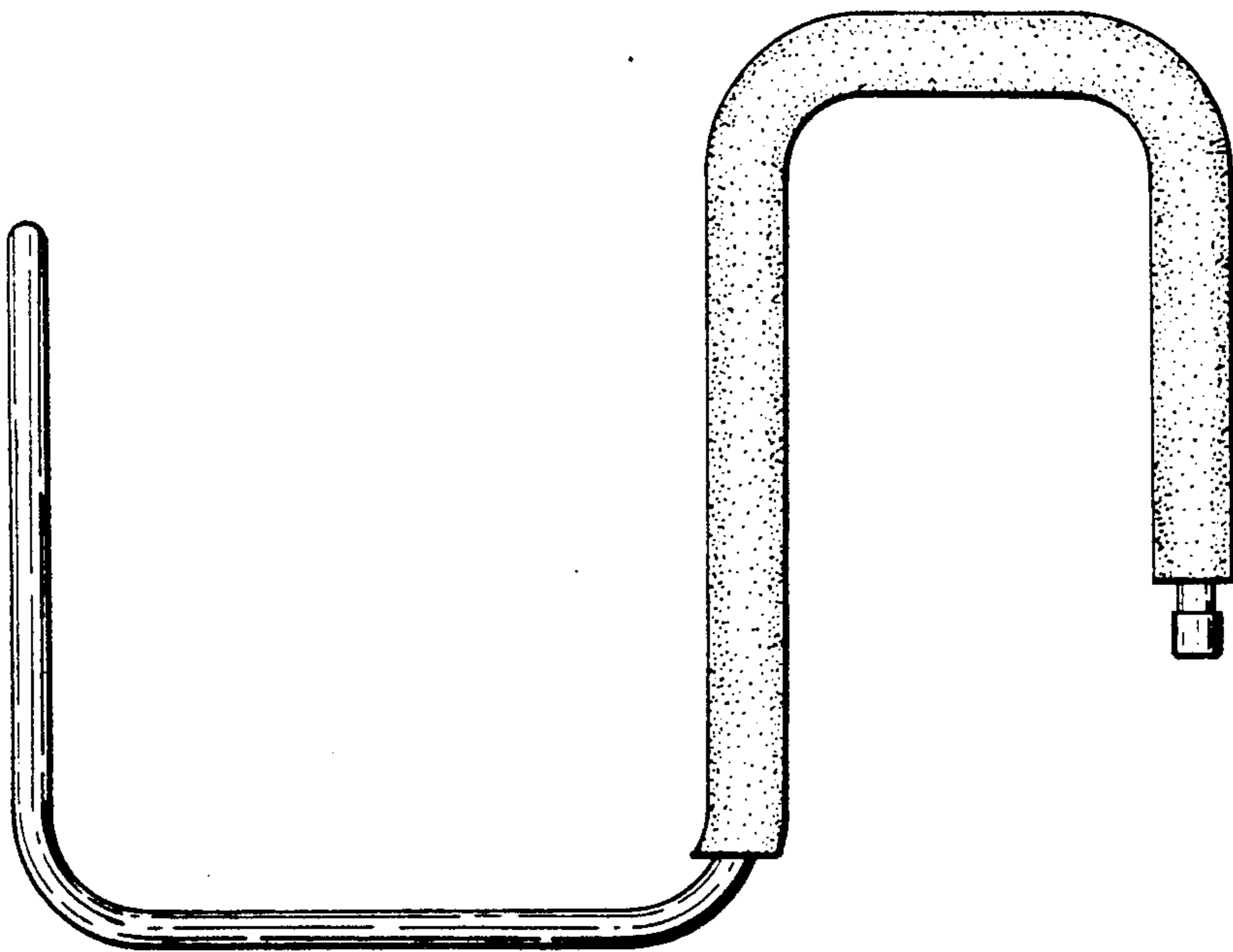

FIG. 2.

