

[54] SEAT CADDY

[75] Inventor: Rex G. Smith, Grand Prairie, Tex.

[73] Assignee: Texas Saddlebags, Inc., Arlington, Tex.

[**] Term: 14 Years

[21] Appl. No.: 288,724

[22] Filed: Dec. 22, 1988

[52] U.S. Cl. D3/40; D3/74

[58] Field of Search D3/40, 30.1, 74, 73, D3/99, 39; 224/273, 276, 275, 277, 42.42, 42.45 R, 42.39, 42.11; 40/904; 296/37.1, 37.8, 78; 211/88, 71, 74, 69.5, 40; 108/12, 43, 44, 46, 45; D14/253, 149; D12/155, 156; D7/553; 220/427

[56] References Cited

U.S. PATENT DOCUMENTS

D. 198,538	6/1964	Stricklin	D3/40
D. 199,993	1/1965	Cohen	D3/40
D. 267,444	1/1983	Ruxton	D3/40
D. 271,442	11/1983	Lehner	D3/74 X
D. 281,545	12/1985	Flanagan	D3/40

3,428,357	2/1969	Lueck	224/275 X
4,796,791	1/1989	Goss et al.	224/42.42 X

Primary Examiner—Louis S. Zarfes
Assistant Examiner—M. N. Pandozzi
Attorney, Agent, or Firm—Daniel Rubin

[57] CLAIM

The ornamental design for a seat caddy, as shown and described.

DESCRIPTION

FIG. 1 is a top perspective view of a seat caddy showing my new design;
FIG. 2 is a left side elevational view thereof the right side being a mirror image thereof;
FIG. 3 is a front elevational view thereof;
FIG. 4 is a rear elevational view thereof;
FIG. 5 is a top plan view thereof;
FIG. 6 is a bottom plan view thereof; and
FIG. 7 is a top perspective view in use on a reduced scale.
The broken line showing of a vehicle seat and seat belt in FIG. 7 is for illustrative purposes only and forms no part of the claimed design.

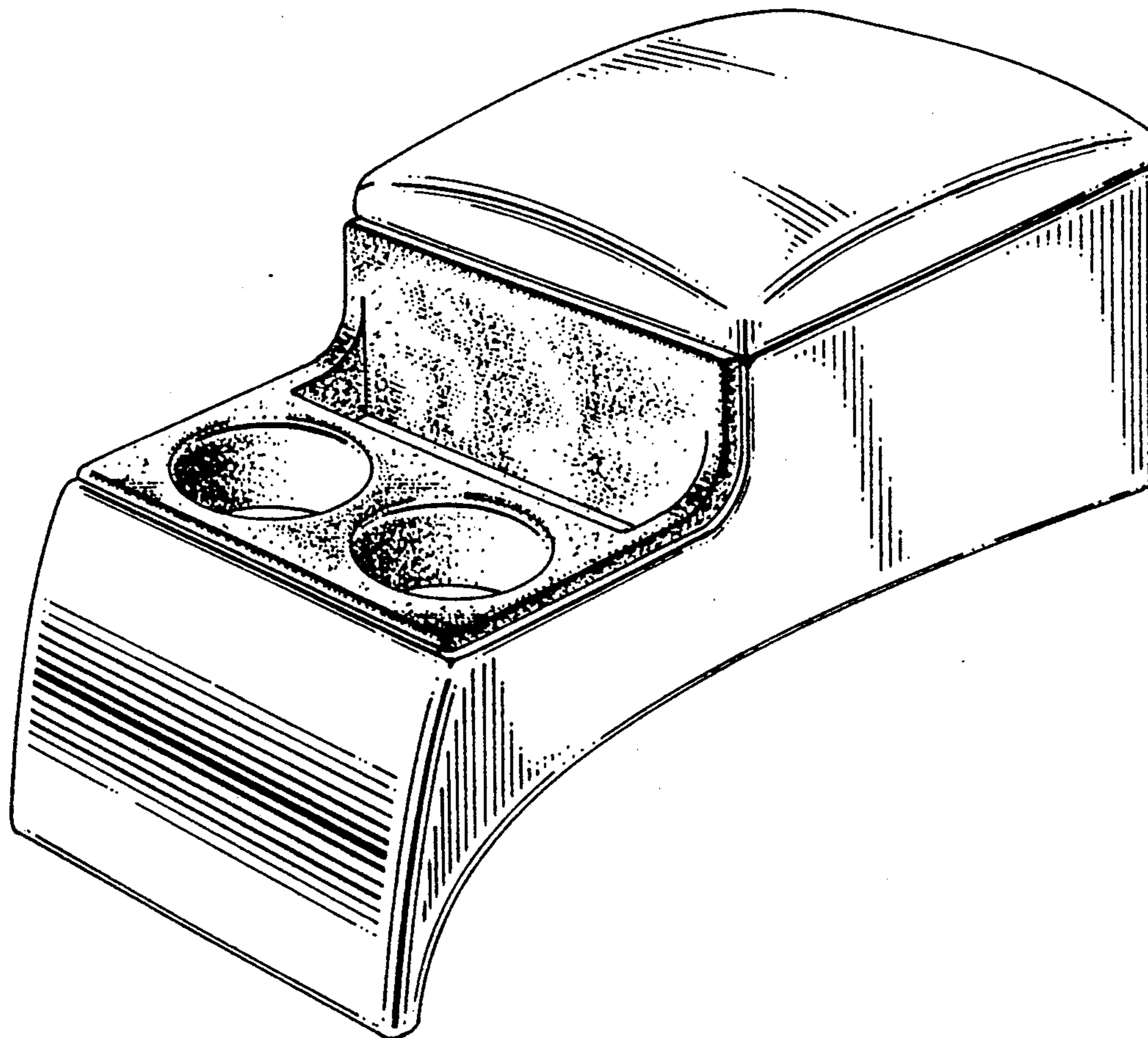

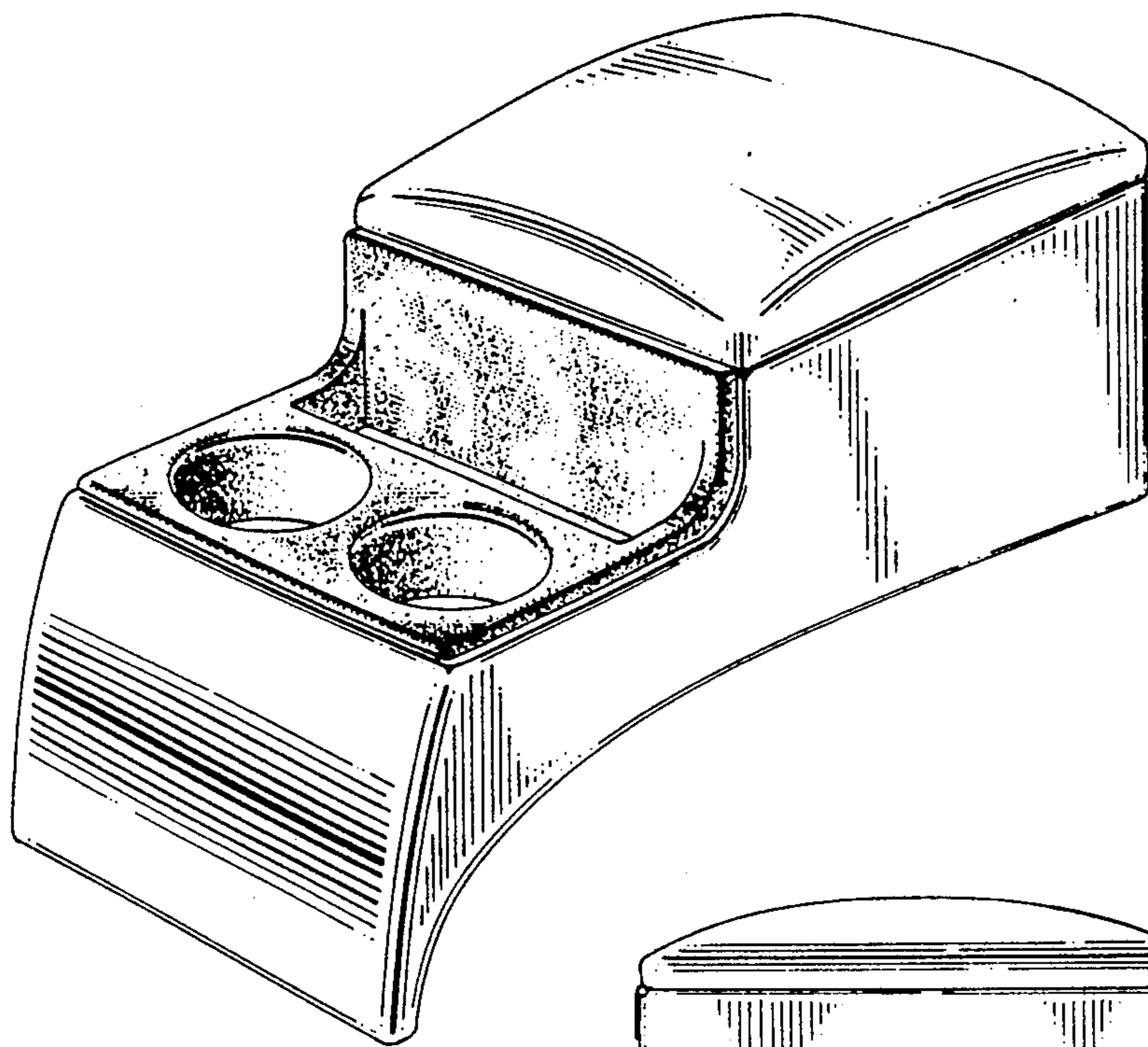

FIG. 1

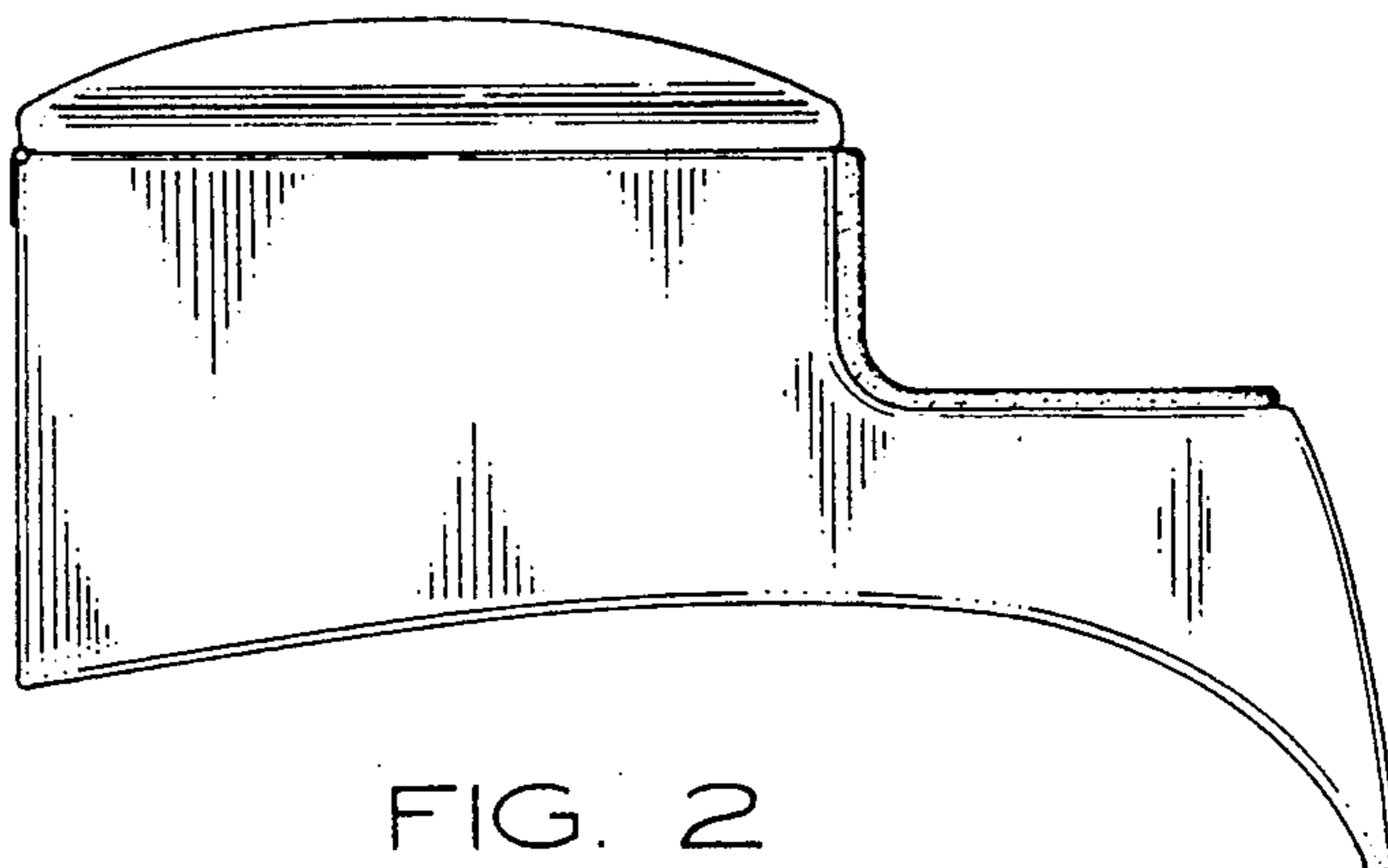

FIG. 2

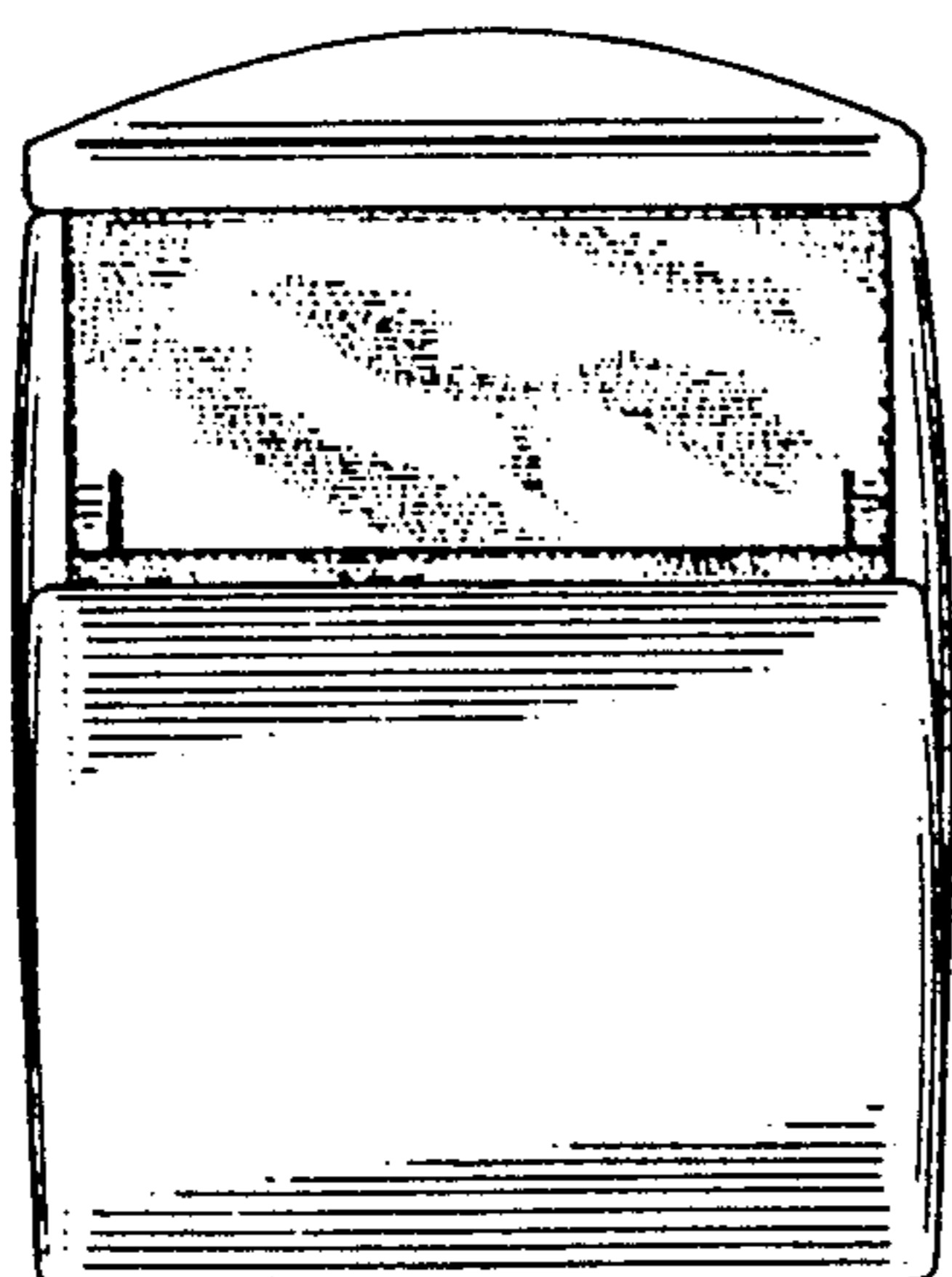

FIG. 3

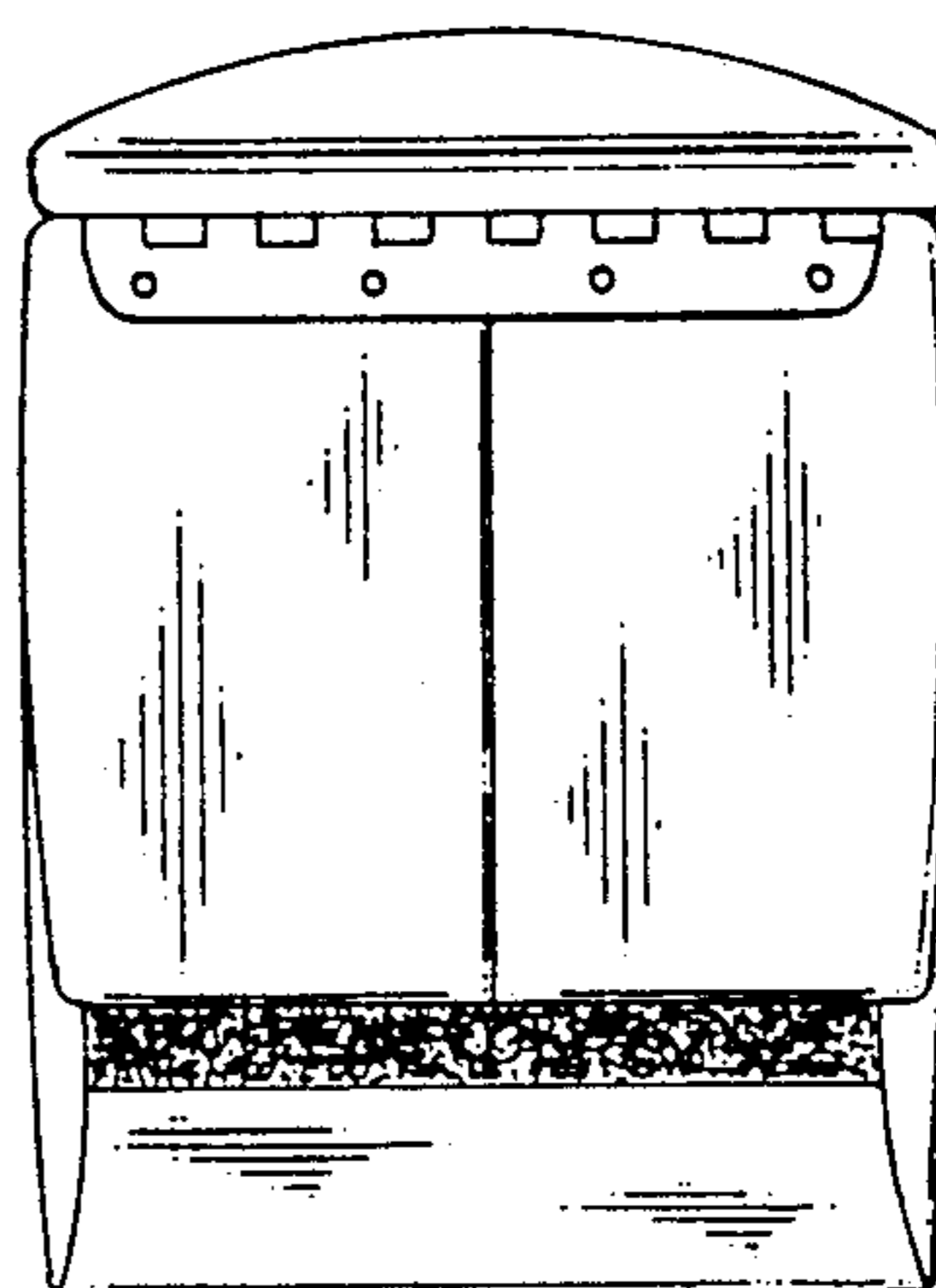

FIG. 4

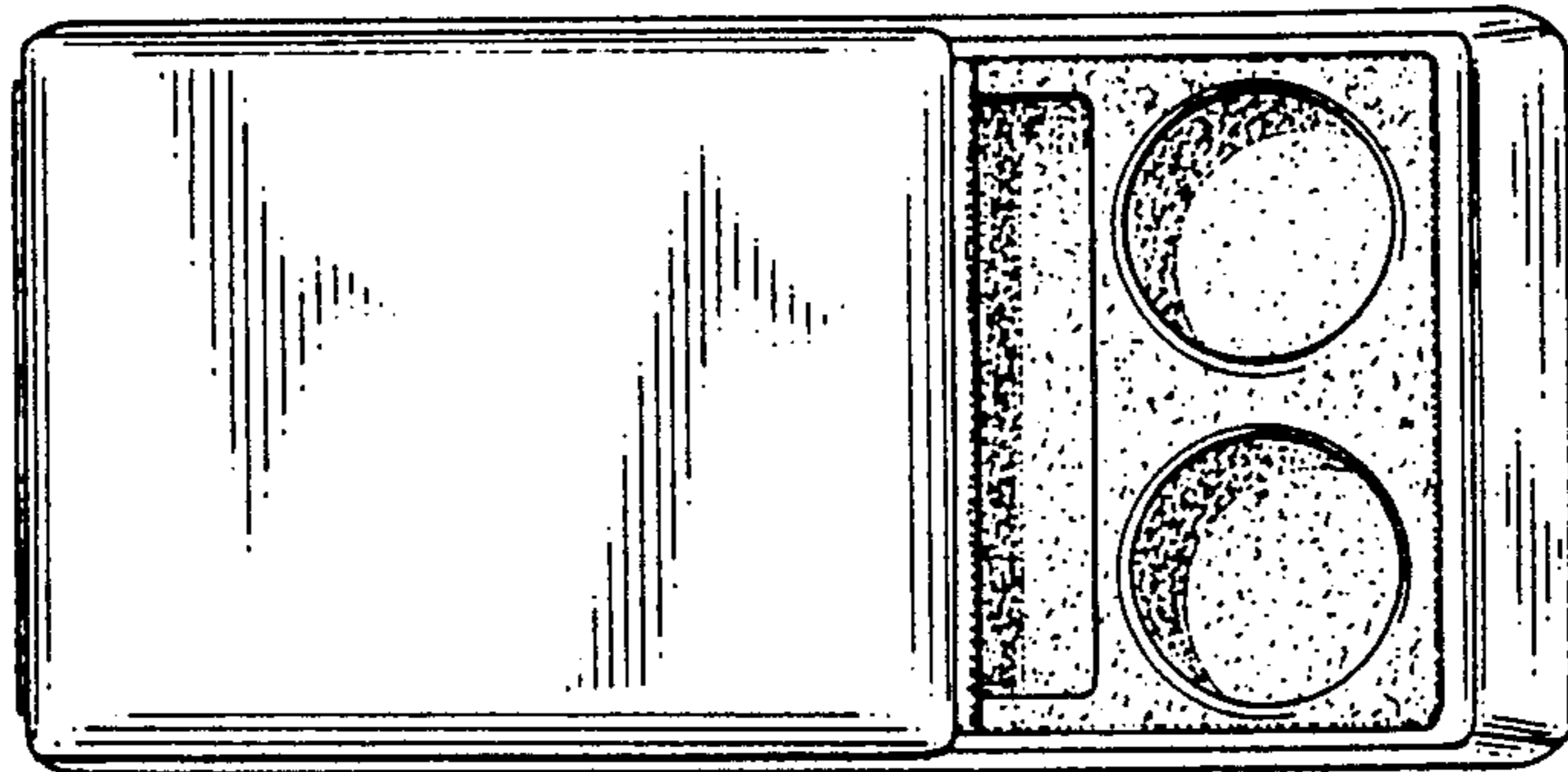

FIG. 5



FIG. 6

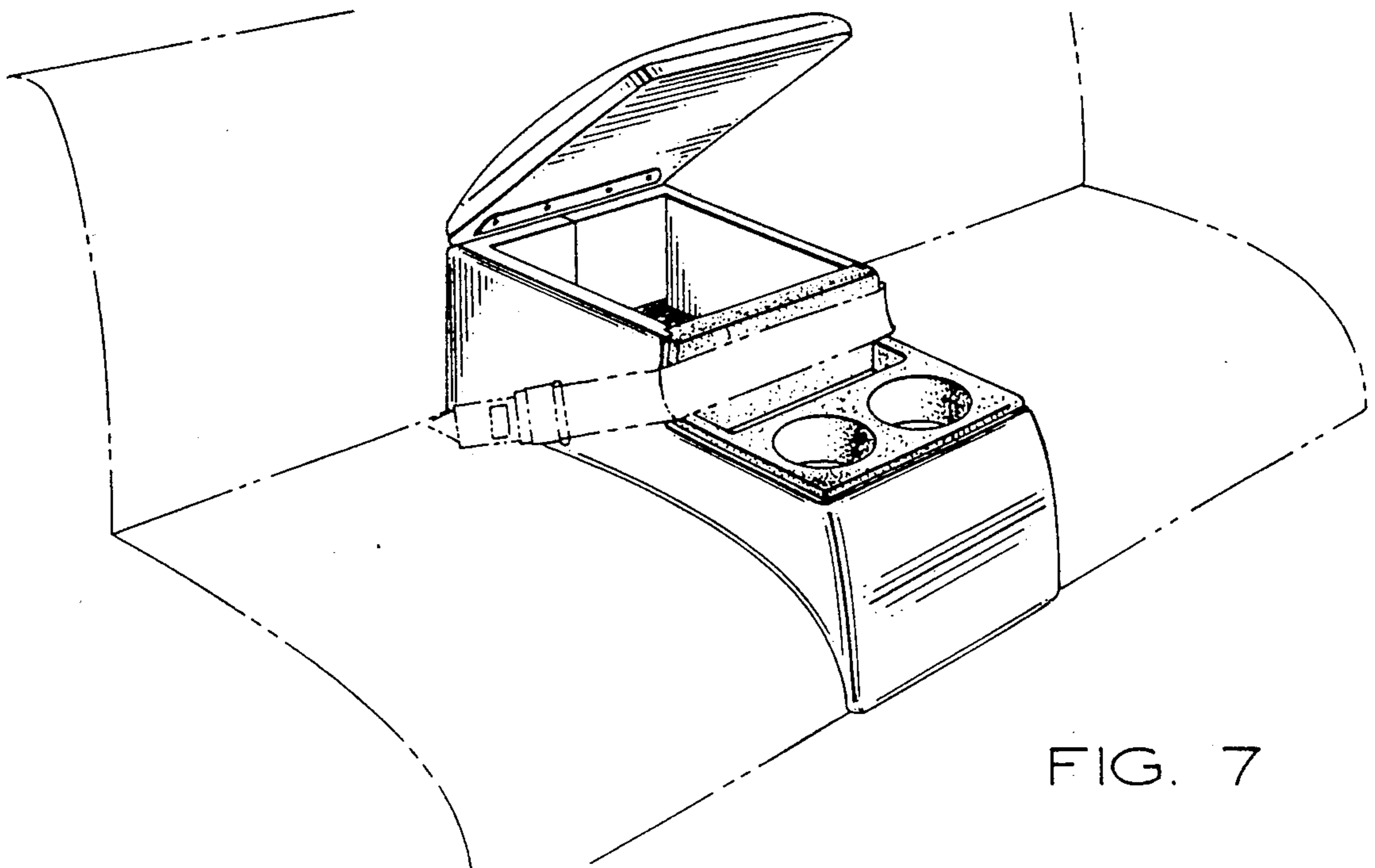

FIG. 7