

[54] TOY RACING CAR

[75] Inventor: Takashi Mochizuki, Shimizu, Japan

[73] Assignee: Kabushiki Kaisha Tamiya Mokei, Shizuoka, Japan

[**] Term: 14 Years

[21] Appl. No.: 365,983

[22] Filed: Jun. 13, 1989

[30] Foreign Application Priority Data

Jan. 17, 1989 [JP] Japan 1-804

[52] U.S. Cl. D21/137

[58] Field of Search D21/136, 137; D12/88, D12/86; 446/470, 471, 454, 456, 444, 446

[56] References Cited
PUBLICATIONS

Hong Kong Toys '88, p. 405, top and center.

Hong Kong Toys, '88, p. 706, center #56.

Hong Kong Toys '88, p. 268, top.

Best Products Catalog, 1987, p. 316, #13.

Primary Examiner—Charles A. Rademaker

Assistant Examiner—R. Barkai

Attorney, Agent, or Firm—Finnegan, Henderson,

Farabow, Garrett & Dunner

[57] CLAIM

The ornamental design for a toy racing car, as shown and described.

DESCRIPTION

FIG. 1 is a perspective view of a toy racing car showing my new design;

FIG. 2 is a front elevational view thereof;

FIG. 3 is a rear elevational view thereof;

FIG. 4 is a right side elevational view thereof;

FIG. 5 is a left side elevational view thereof;

FIG. 6 is a top plan view thereof; and

FIG. 7 is a bottom plan view thereof.

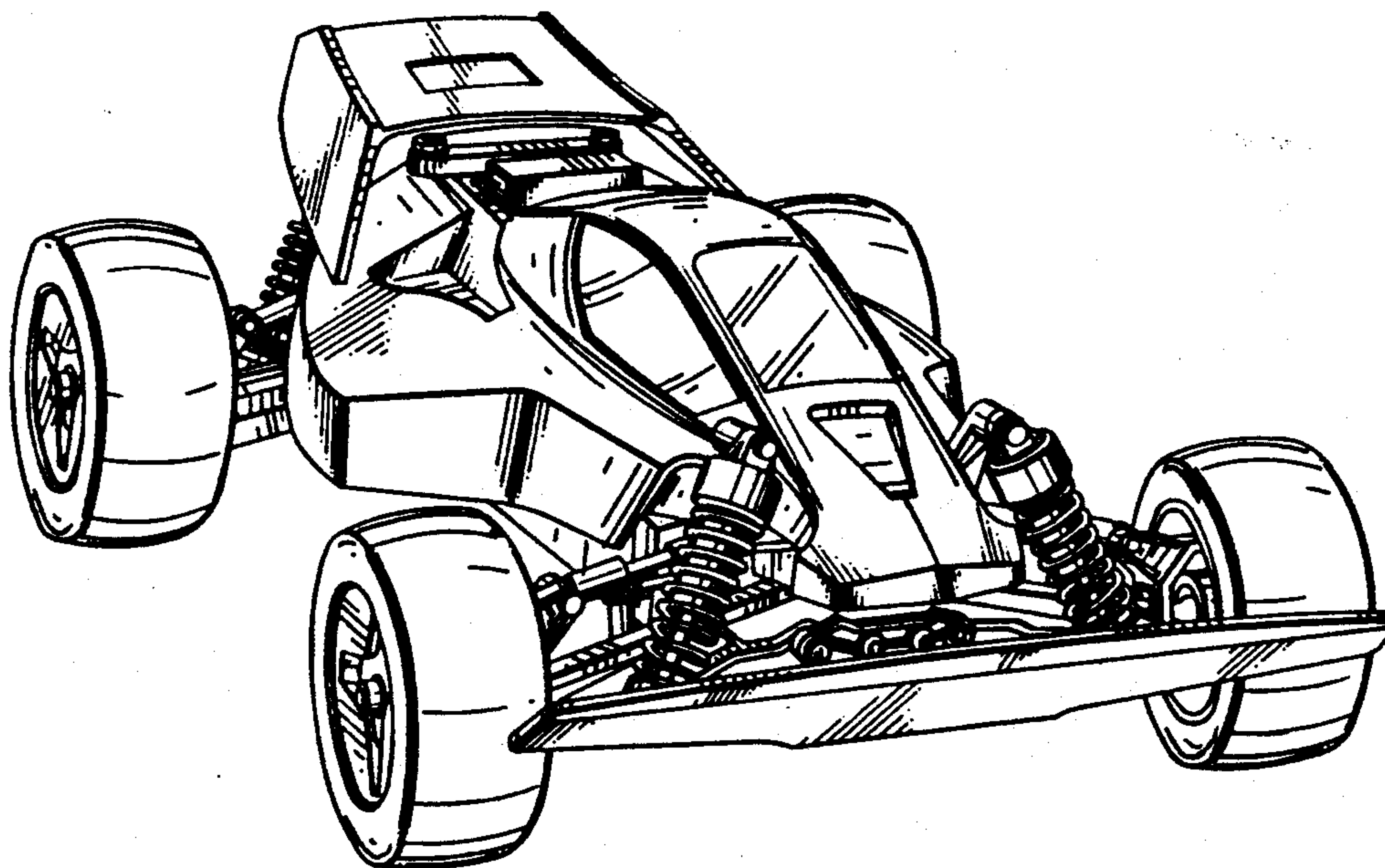

FIG. 1

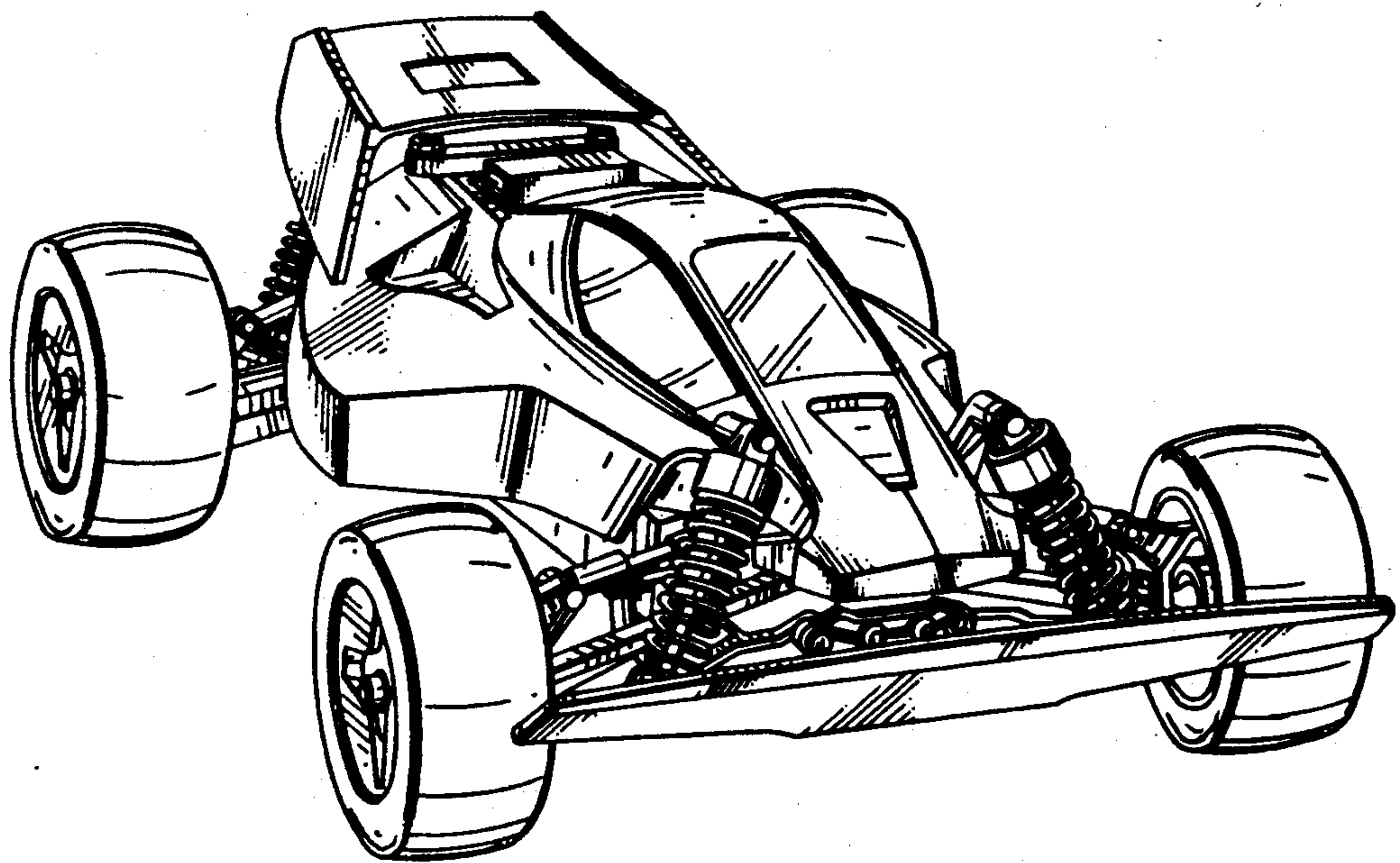

FIG. 2

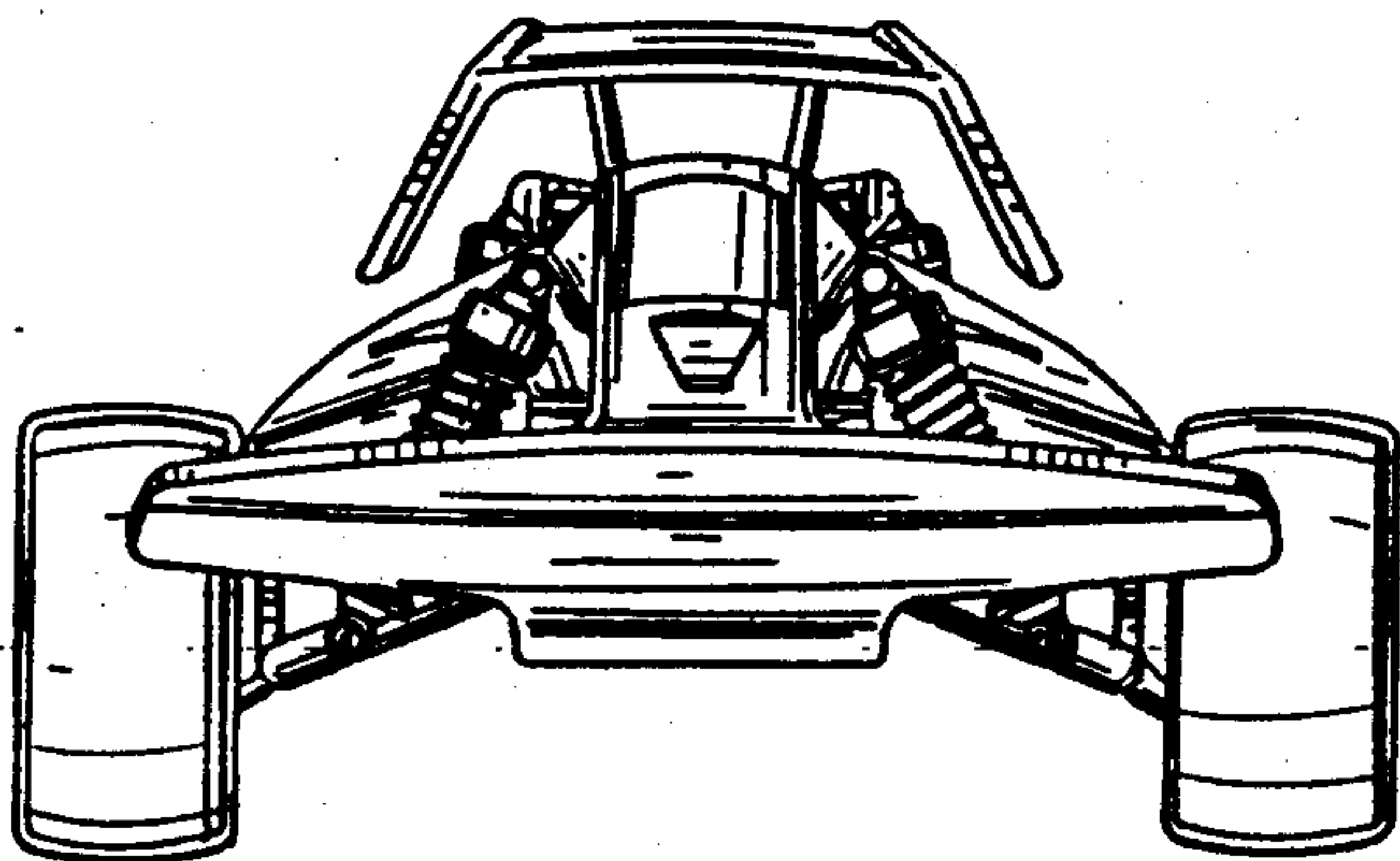

FIG. 3

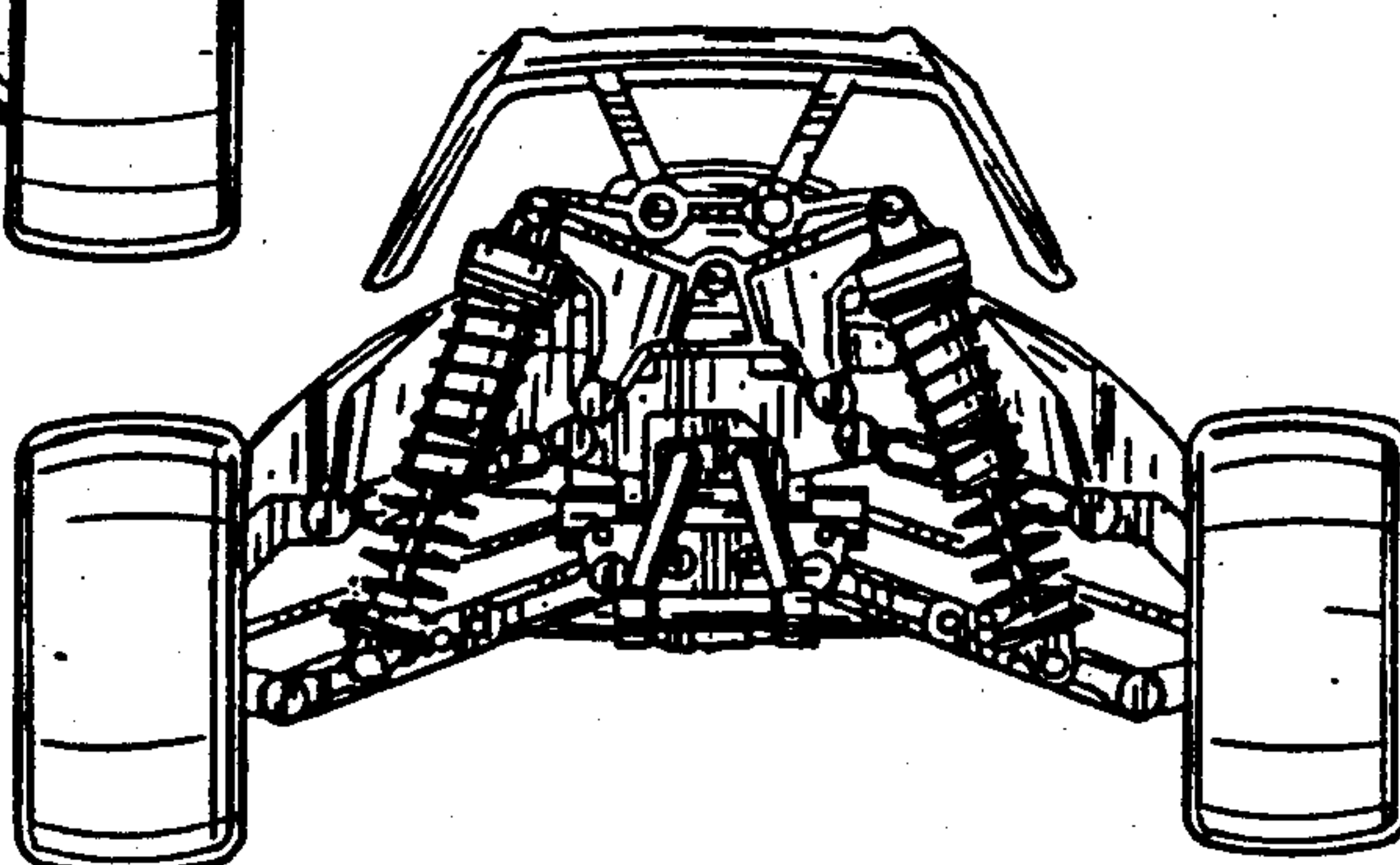

FIG. 4

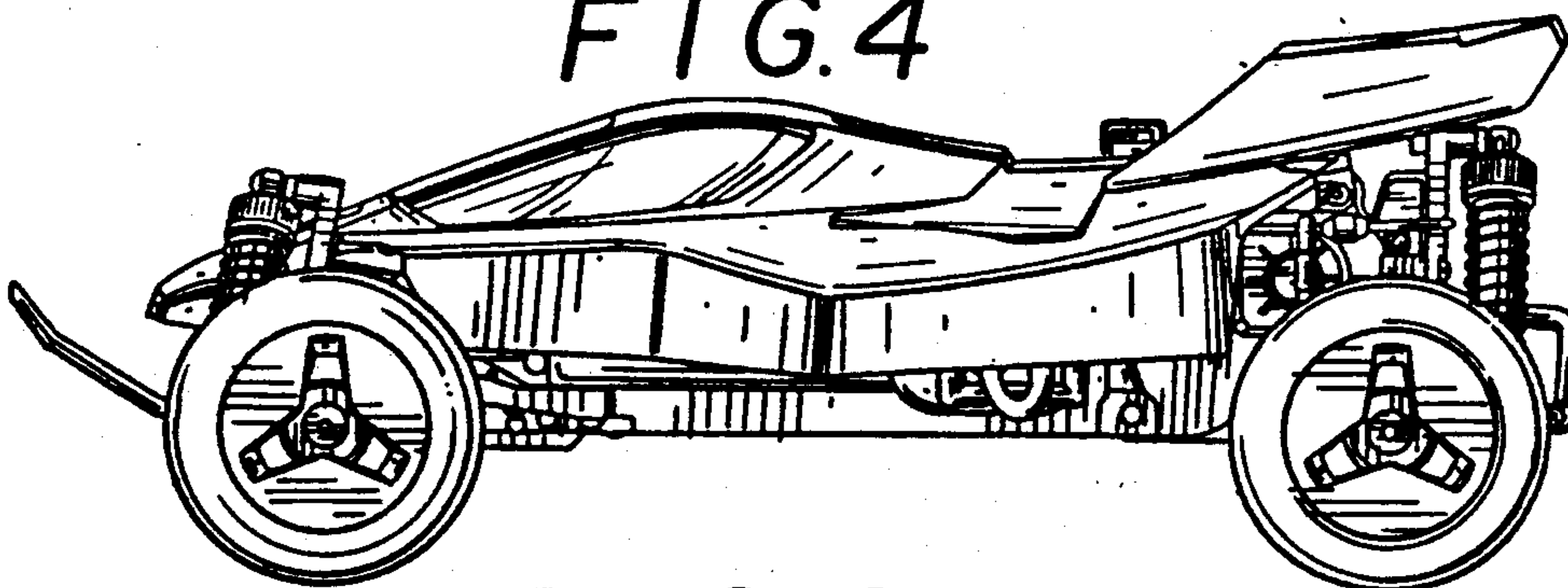

FIG. 5

