

[54] SIMULATIVE DRIVING TOY

D. 275,023 8/1984 Nuttall D21/142
4,363,482 12/1982 Goldfarb 273/85 G X

[75] Inventor: Thomas Ng Chuk-Sun, Hong Kong,
Hong Kong

OTHER PUBLICATIONS

[73] Assignee: Blue Box Toy Factory Limited, Hong
Kong

Playthings, 1981, p. 30, Stock No. 7011, bottom left of
the page.

[**] Term: 14 Years

Playthings, 1980, p. 32, Stk. No. 7034, top of the page.

[21] Appl. No.: 280,625

Vending Times, 7/79, p. 60, 18 Wheeler, top left of the
page.

[22] Filed: Dec. 5, 1988

Primary Examiner—Bernard Ansher
Assistant Examiner—Prabhakar Deshmukh
Attorney, Agent, or Firm—Pollock, Vande Sande &
Priddy

[30] Foreign Application Priority Data

Sep. 23, 1988 [GB] United Kingdom 1053714

[52] U.S. Cl. D21/142

[58] Field of Search D21/13, 142, 143;
273/85 G, 1 GC, 1 E, 237, DIG. 28

[57] CLAIM

The ornamental design for a simulative driving toy, as
shown.

[56] References Cited

DESCRIPTION

U.S. PATENT DOCUMENTS

- D. 243,625 3/1977 Sauter D21/13
- D. 257,780 1/1981 Strauss D21/142
- D. 263,406 3/1982 Orenstein D21/142
- D. 265,839 8/1982 Kite et al. D21/13
- D. 270,460 9/1983 Burtoft et al. D21/13

FIG. 1 is a left side elevation of a simulative driving toy
showing my new design; the right side elevation being
a mirror image thereof;
FIG. 2 is a top plan view thereof;
FIG. 3 is a bottom plan view thereof; and
FIG. 4 is a bottom and rear perspective view thereof.

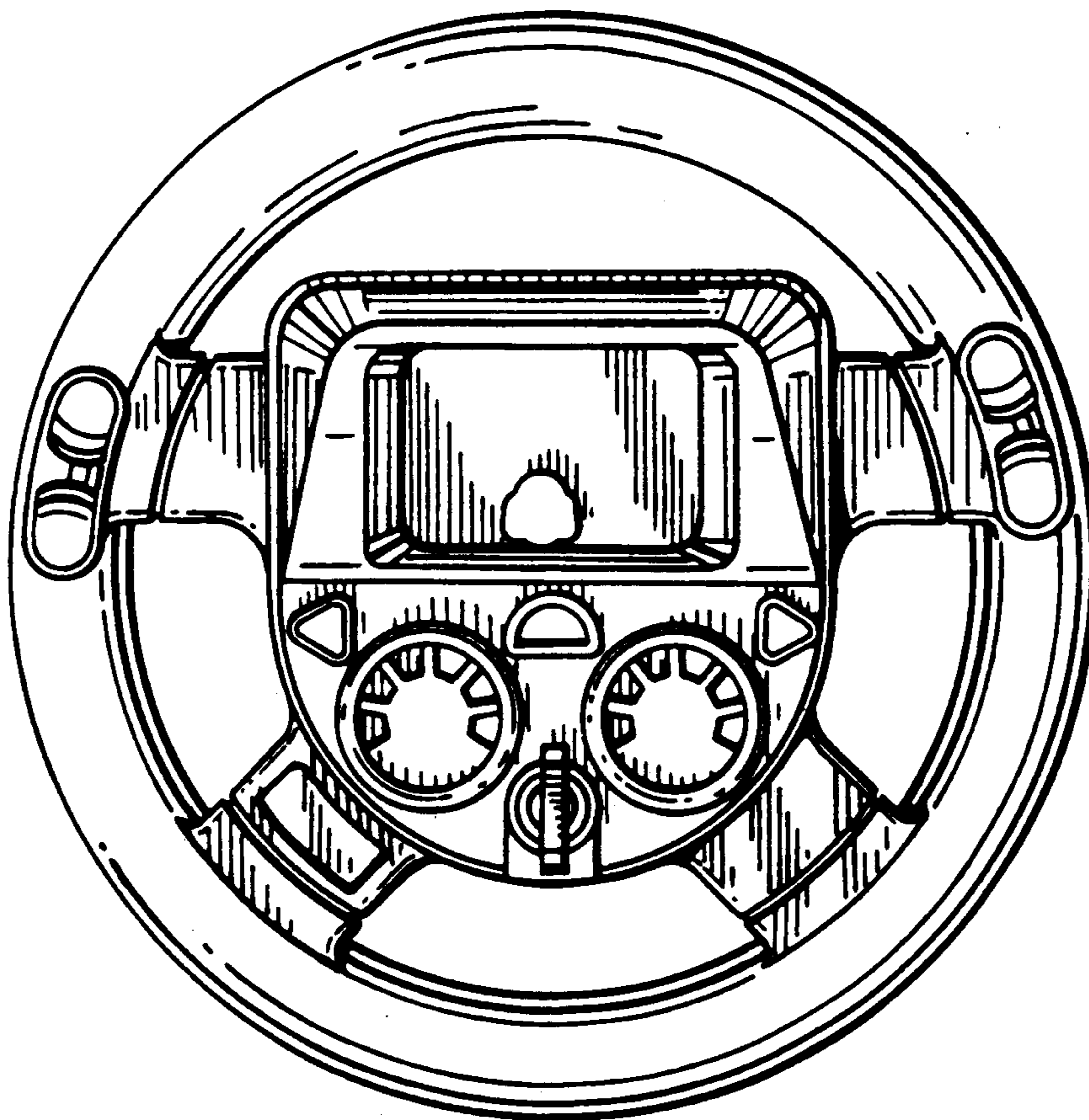

FIG. 1

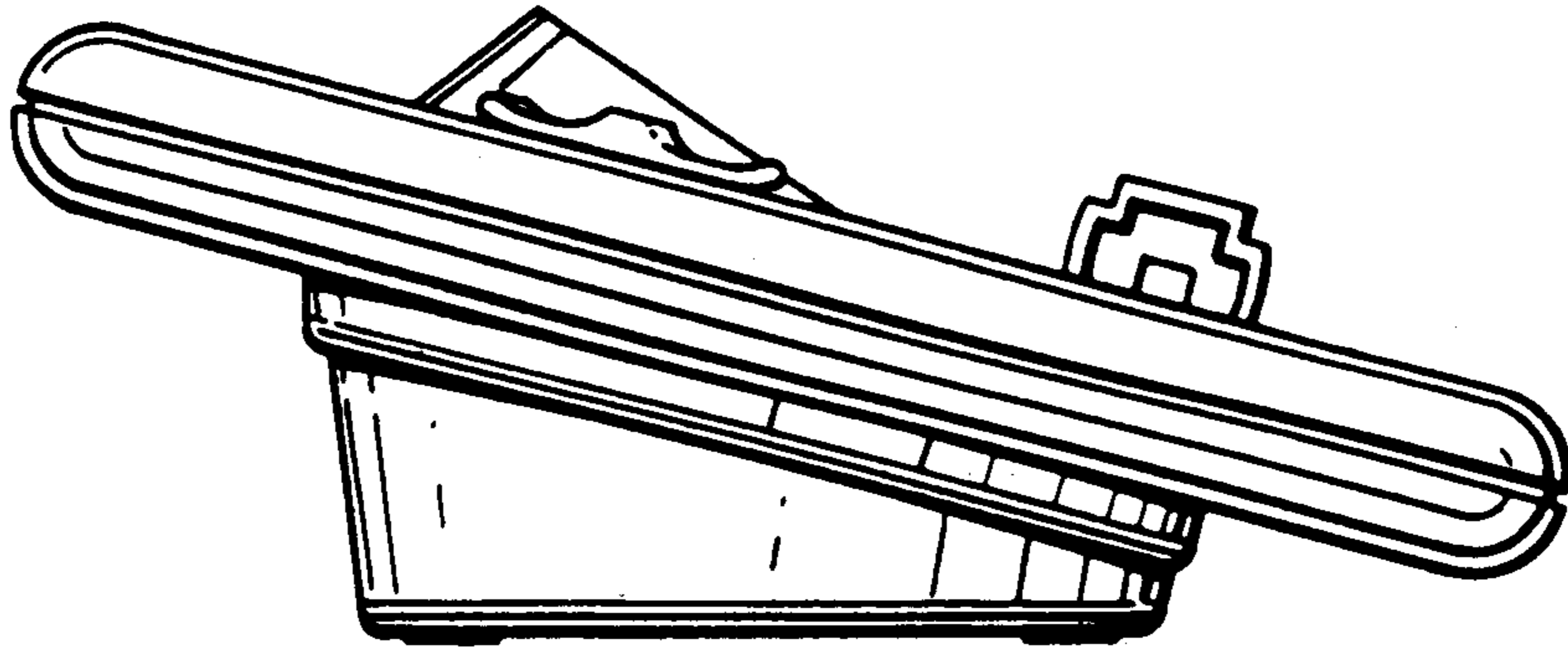

FIG. 2

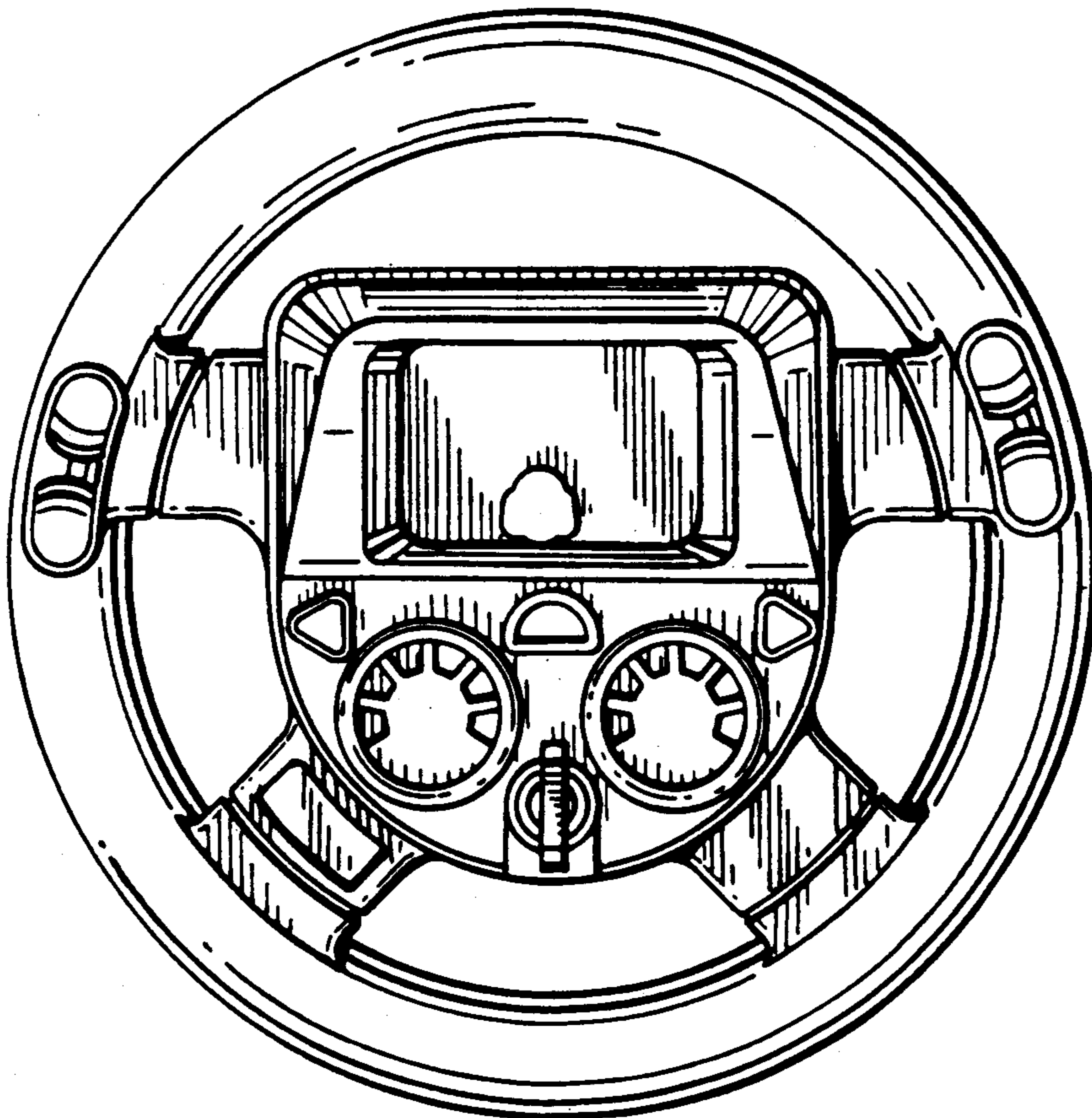

FIG. 3

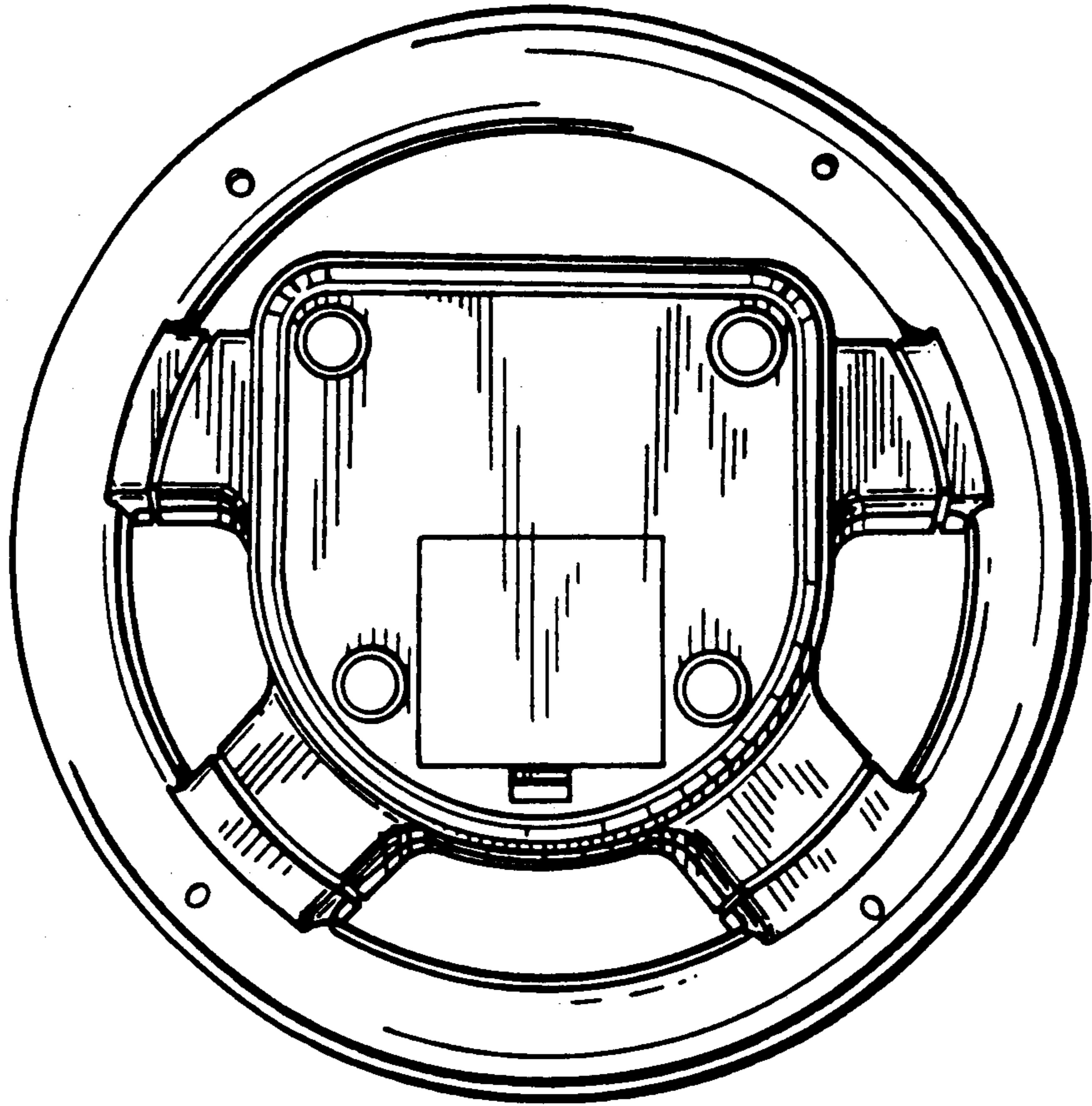

FIG. 4

