

[54] **TIE RAIL FOR PICK-UP TRUCKS, BOATS OR THE LIKE**

[76] **Inventor: Joseph S. Geeck, III, 701 Roseland Pkwy., Harahan, La. 70123**

[**] **Term: 14 Years**

[21] **Appl. No.: 240,849**

[22] **Filed: Sep. 6, 1988**

[52] **U.S. Cl. D12/155**

[58] **Field of Search D12/98, 155, 83; 410/110, 96, 101, 115, 116, 108, 106**

[56] **References Cited**

U.S. PATENT DOCUMENTS

3,098,457	7/1963	Shaver	410/110
4,604,013	8/1986	Elwell et al.	410/106
4,650,382	3/1987	Johnson	410/110
4,872,719	10/1989	Cardwell	410/110

Primary Examiner—James M. Gandy
Assistant Examiner—Melody Brown
Attorney, Agent, or Firm—John F. Sieberth

[57] **CLAIM**

The ornamental design for a tie rail for pick-up trucks, boats or the like, as shown and described.

DESCRIPTION

FIG. 1 is a fragmentary perspective view of a tie rail for pick-up trucks, boats or the like showing my new design, it being understood that the tie rail is shown broken away to indicate indeterminate length;
FIG. 2 is a fragmentary front elevation view thereof;
FIG. 3 is a fragmentary top plan view thereof;
FIG. 4 is a fragmentary front elevation view of a tie rail for pick-up trucks, boats or the like showing a second embodiment of my new design, the sole difference being in the shape of the openings;
FIG. 5 is a fragmentary front elevation view of a tie rail for pick-up trucks, boats or the like showing a third embodiment of my new design, the sole difference being in the shape of the openings;
FIG. 6 is an enlarged fragmentary sectional view of all three embodiments taken along line 6—6 in FIGS. 1, 2, 4 and 5; and
FIG. 7 is an end elevation view of each of the embodiments shown in FIGS. 2, 4 and 5.

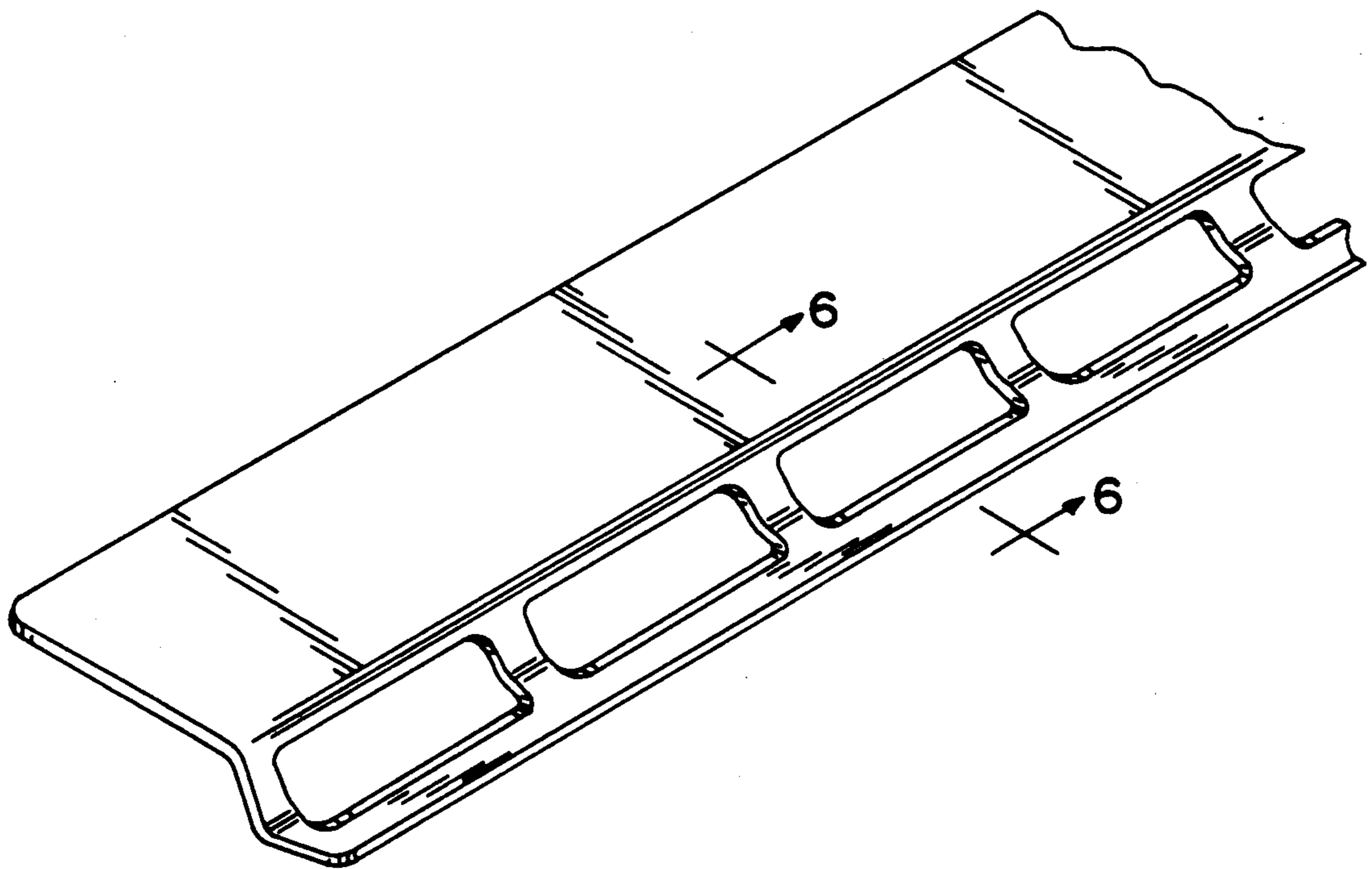

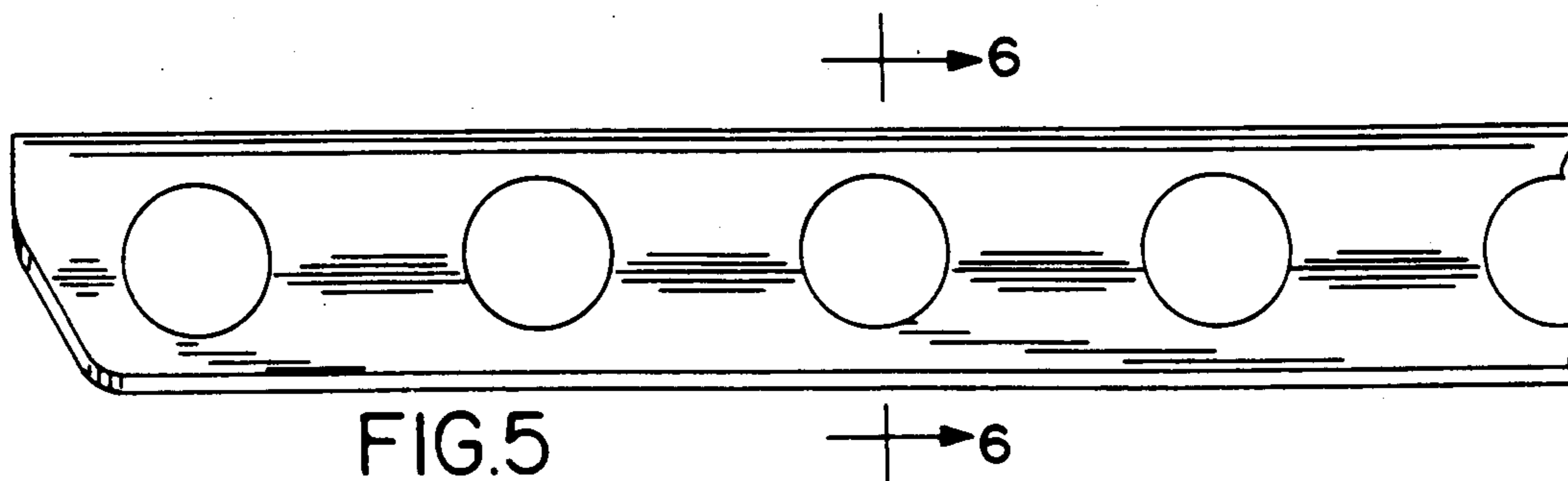
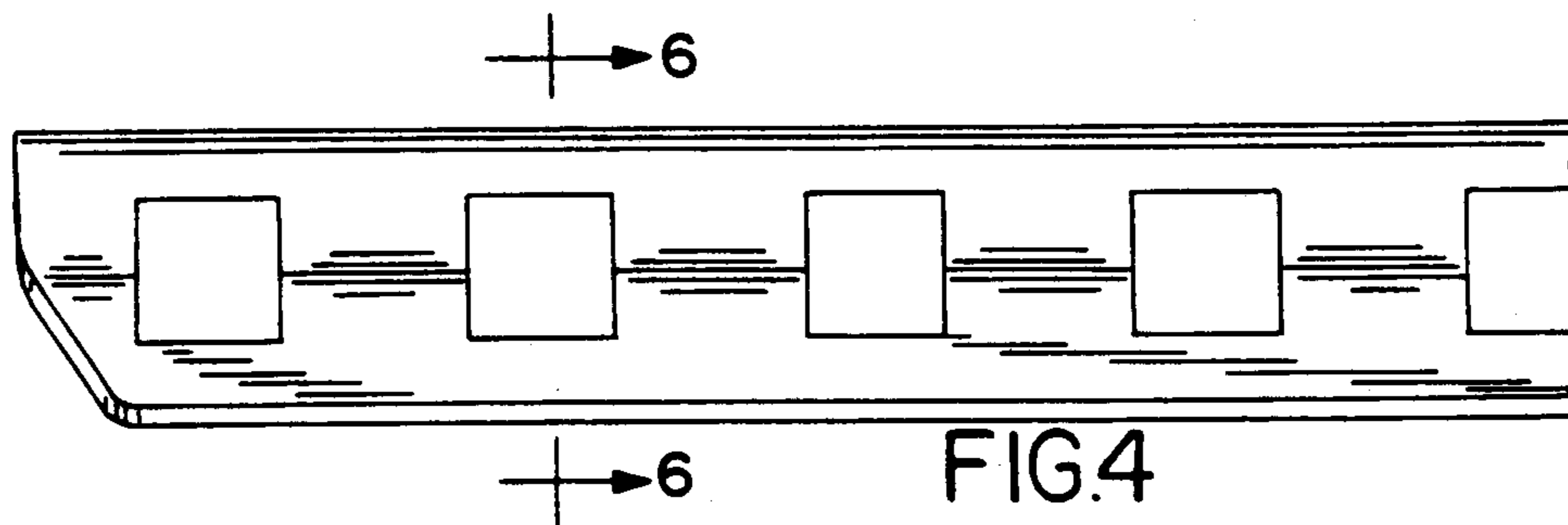
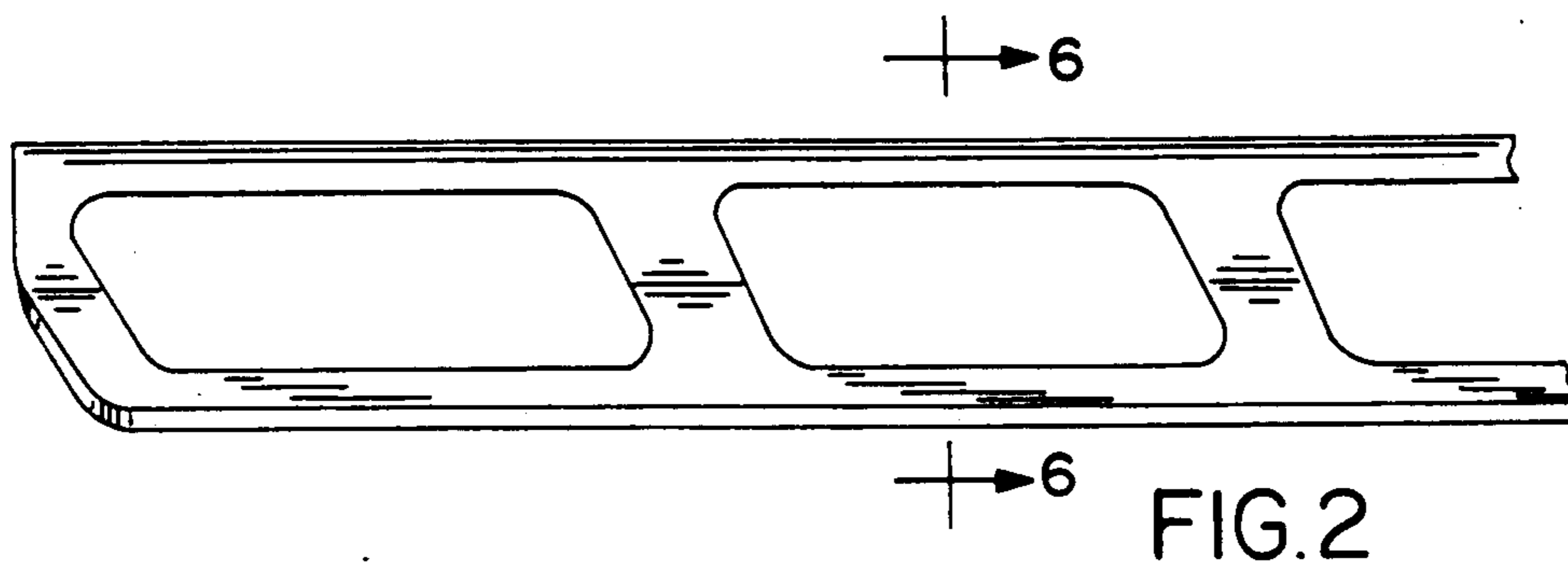
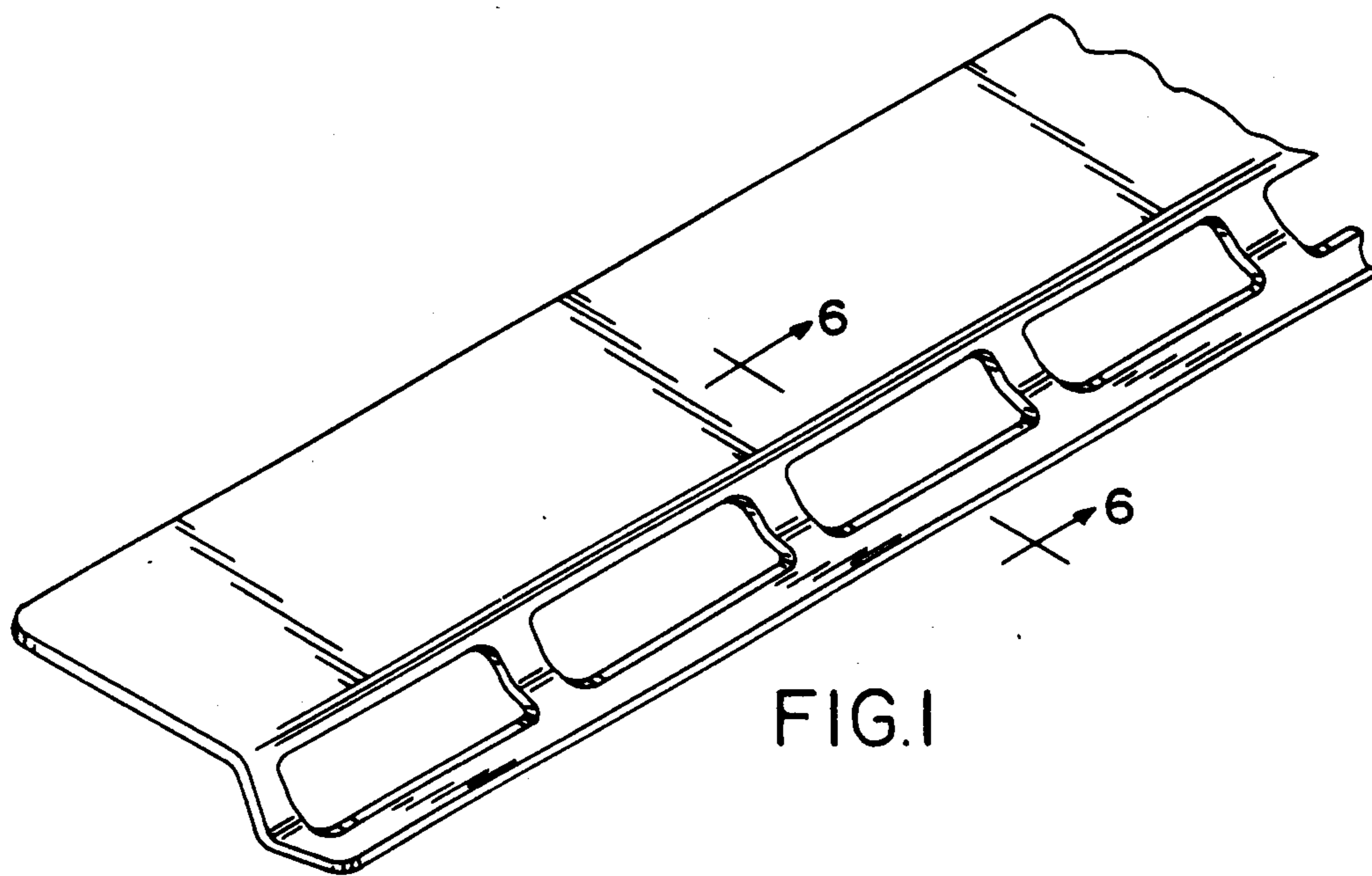

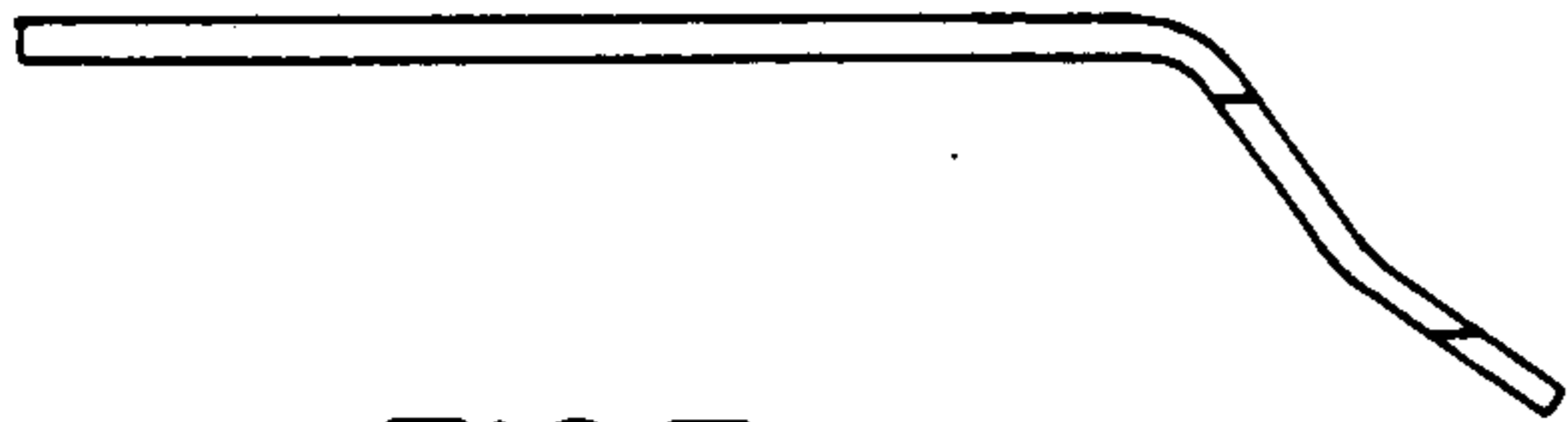

FIG. 7

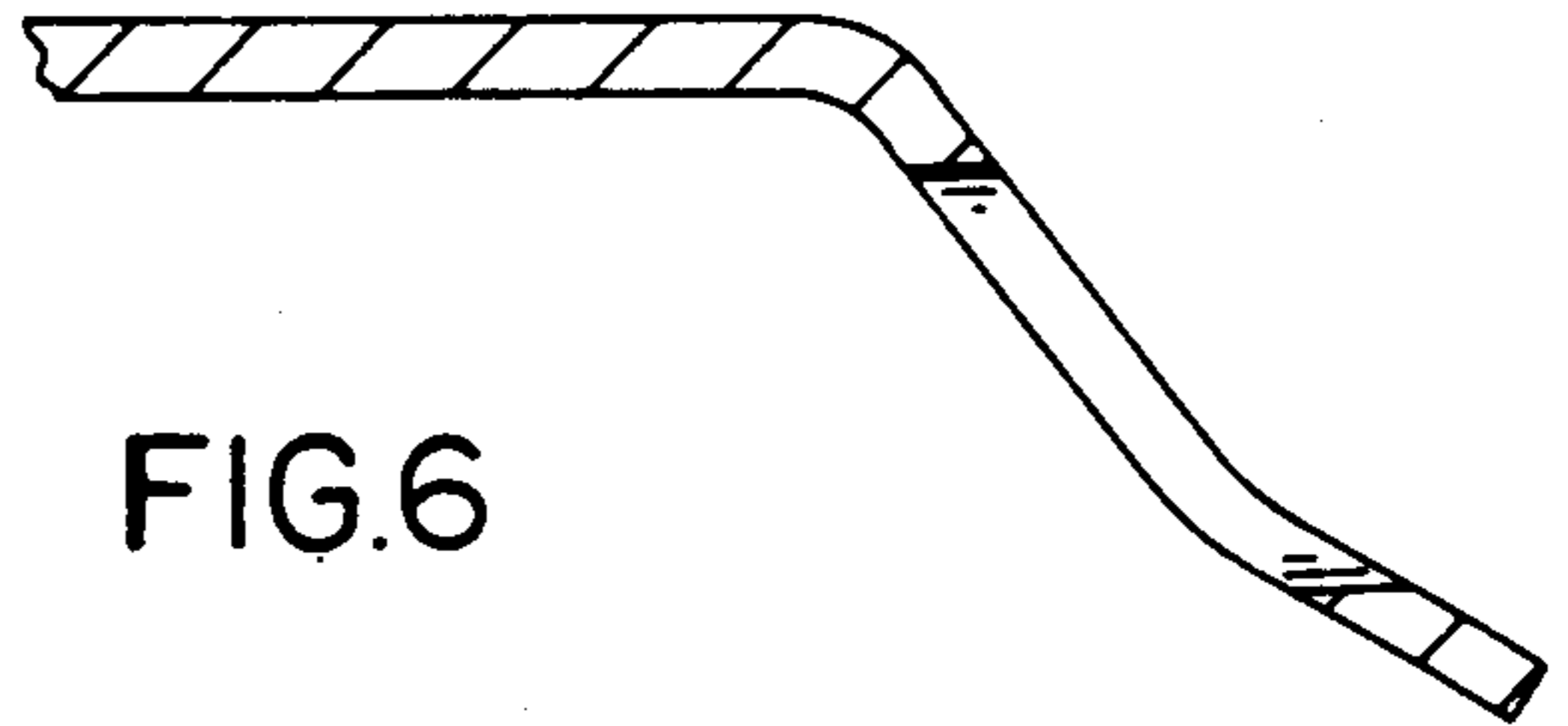

FIG. 6

FIG. 3

