

[54] BREATHER ASSEMBLY FOR COMBUSTION ENGINE

[75] Inventors: Thomas L. Davis, Tulsa; Roy A. Harper, Jr., Broken Arrow, both of Okla.

[73] Assignee: Arrow Specialty Company, Tulsa, Okla.

[\*\*] Term: 14 Years

[21] Appl. No.: 272,264

[22] Filed: Nov. 16, 1988

[52] U.S. Cl. .... D15/5

[58] Field of Search ..... D15/1, 5-7; 123/119, 41.86

[56] References Cited

U.S. PATENT DOCUMENTS

- D. 106,914 11/1937 Ginter ..... D15/5
- D. 152,516 2/1949 Brown ..... D15/7
- D. 284,380 6/1986 Berg et al. .... D15/7
- 2,493,617 1/1950 Chubbuck .

- 3,087,474 4/1968 Catha .
- 3,550,567 12/1970 Crow .
- 3,721,069 3/1973 Walker .
- 3,875,916 4/1975 Patton .
- 4,579,092 4/1986 Kandler .

FOREIGN PATENT DOCUMENTS

- 1255642 12/1971 United Kingdom .

Primary Examiner—Louis S. Zarfes  
Assistant Examiner—R. T. Seifert  
Attorney, Agent, or Firm—Edgar A. Zarins; Malcolm L. Sutherland

[57] CLAIM

The ornamental design for a breather assembly for combustion engine, as shown and described.

DESCRIPTION

FIG. 1 is a perspective view of a breather assembly for combustion engine showing our new design; FIG. 2 is a side elevational view thereof; FIG. 3 is a top plan view thereof; and FIG. 4 is a bottom plan view thereof.

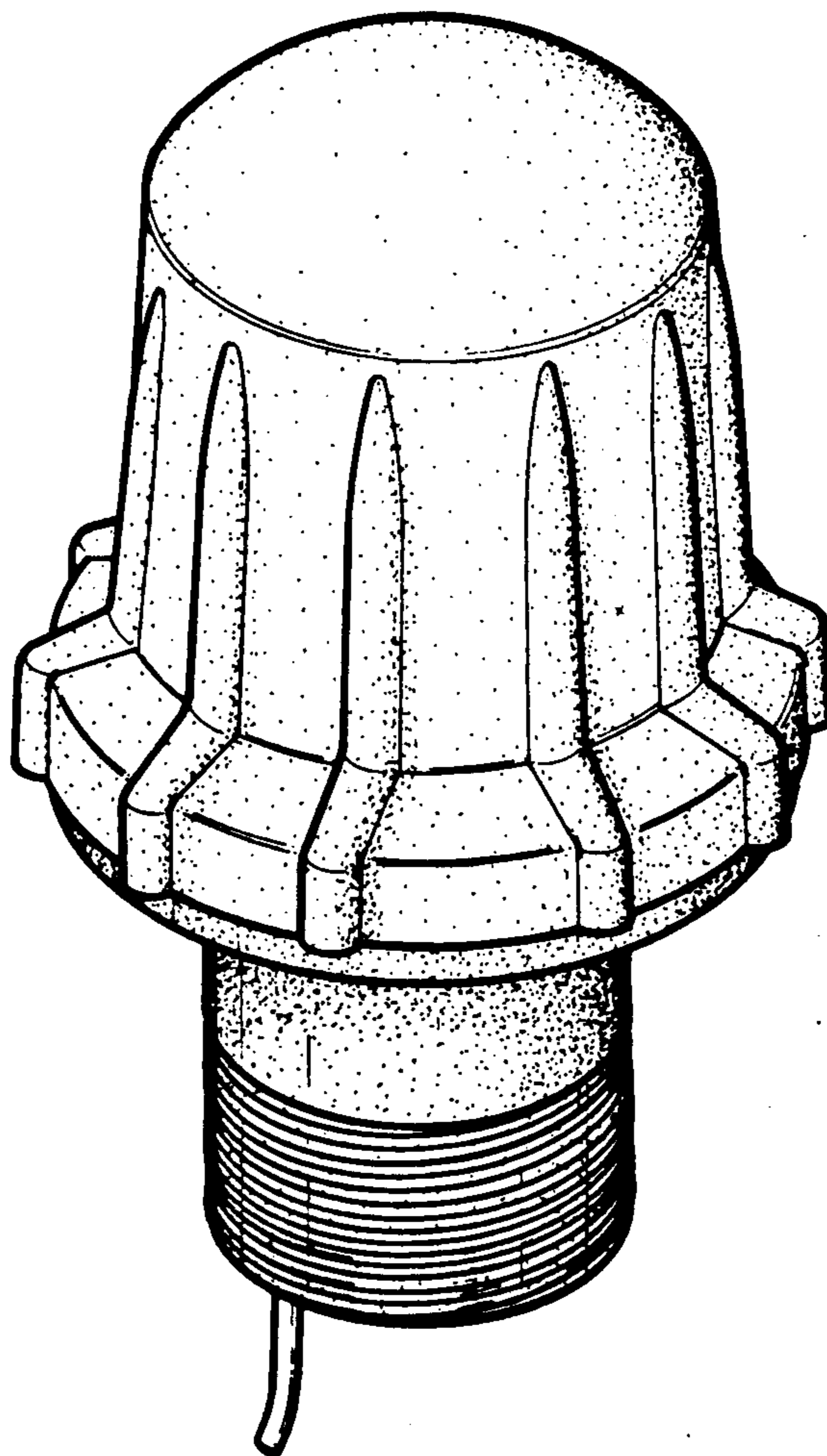

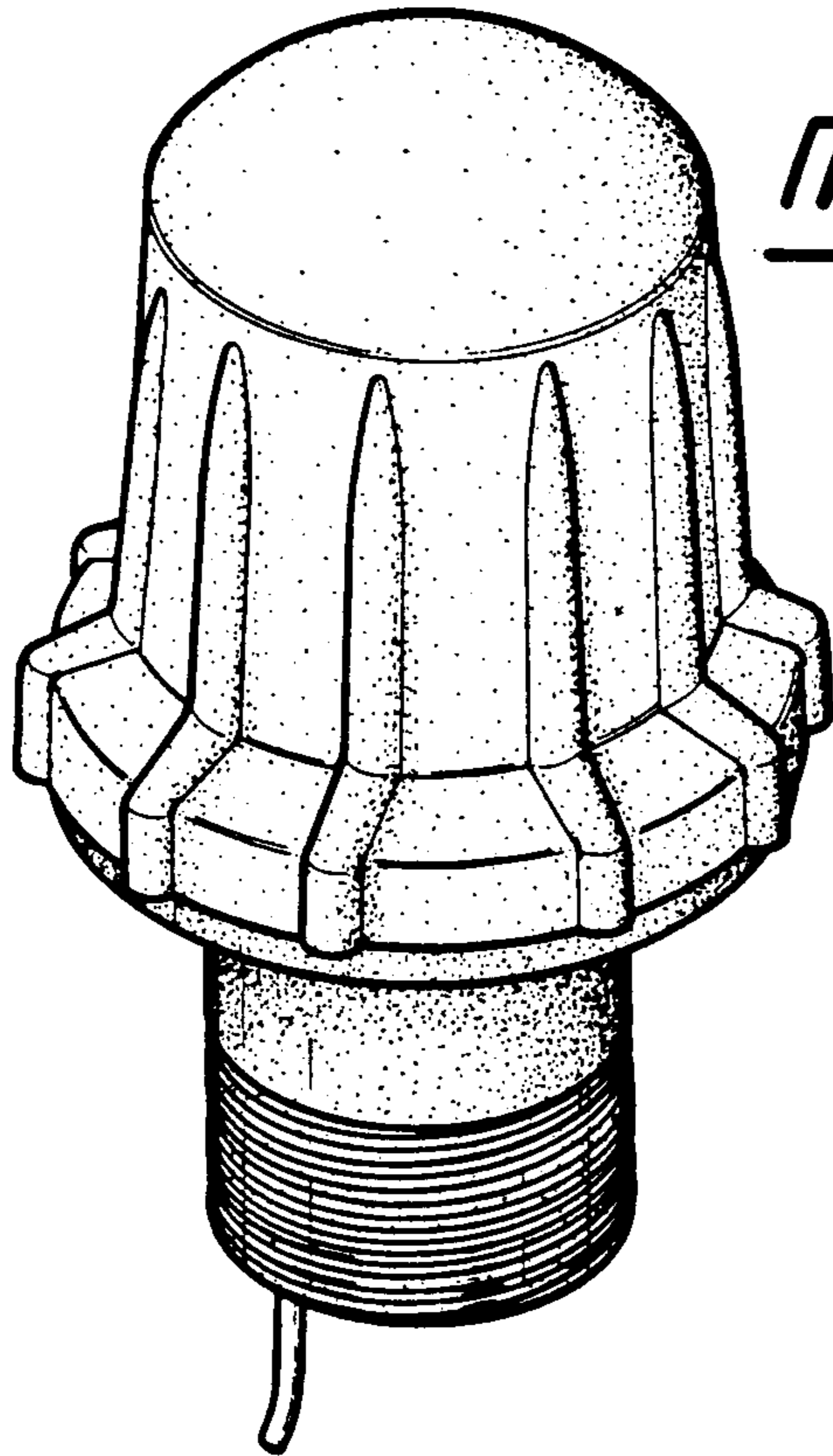

Fig-1

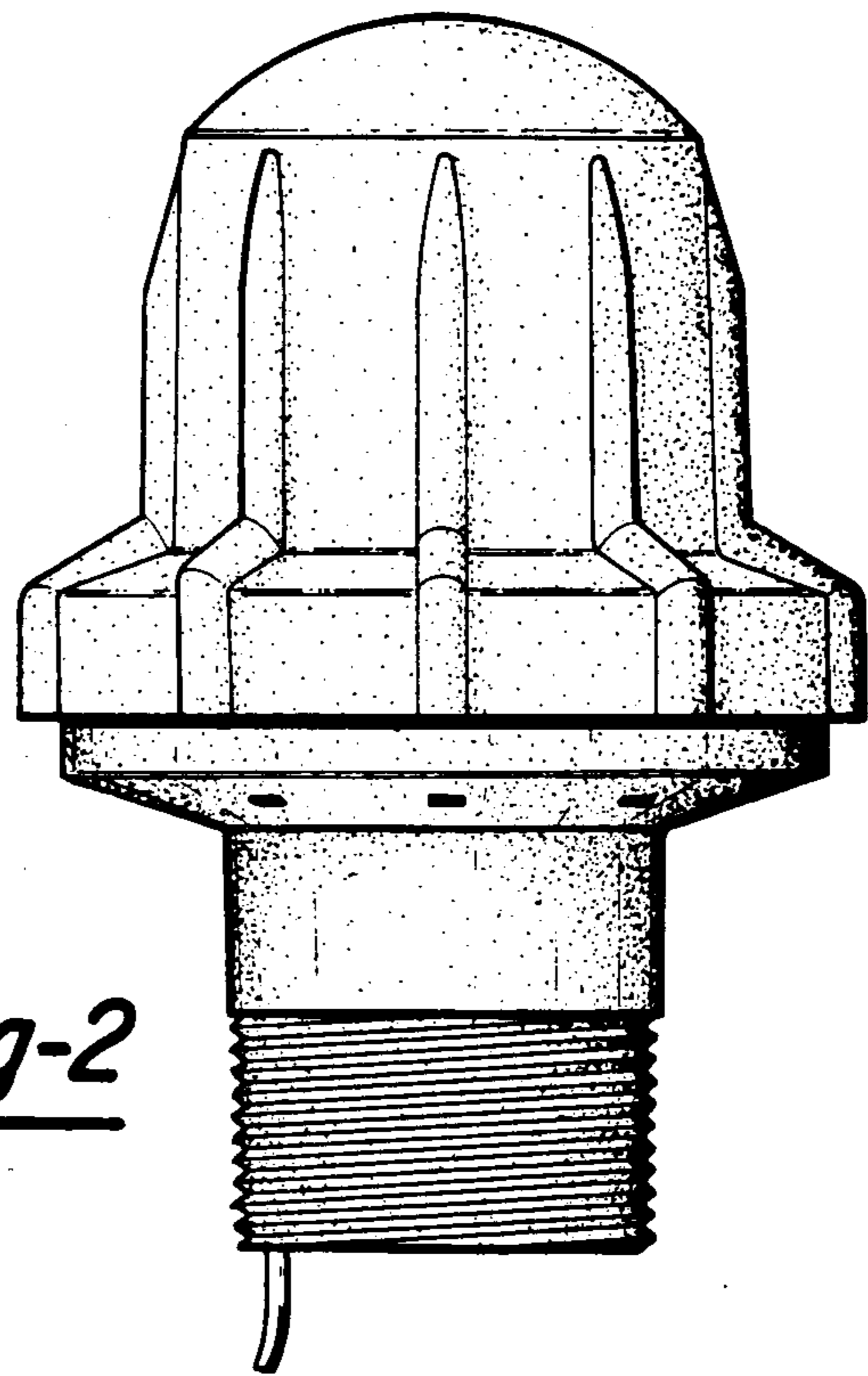

Fig-2

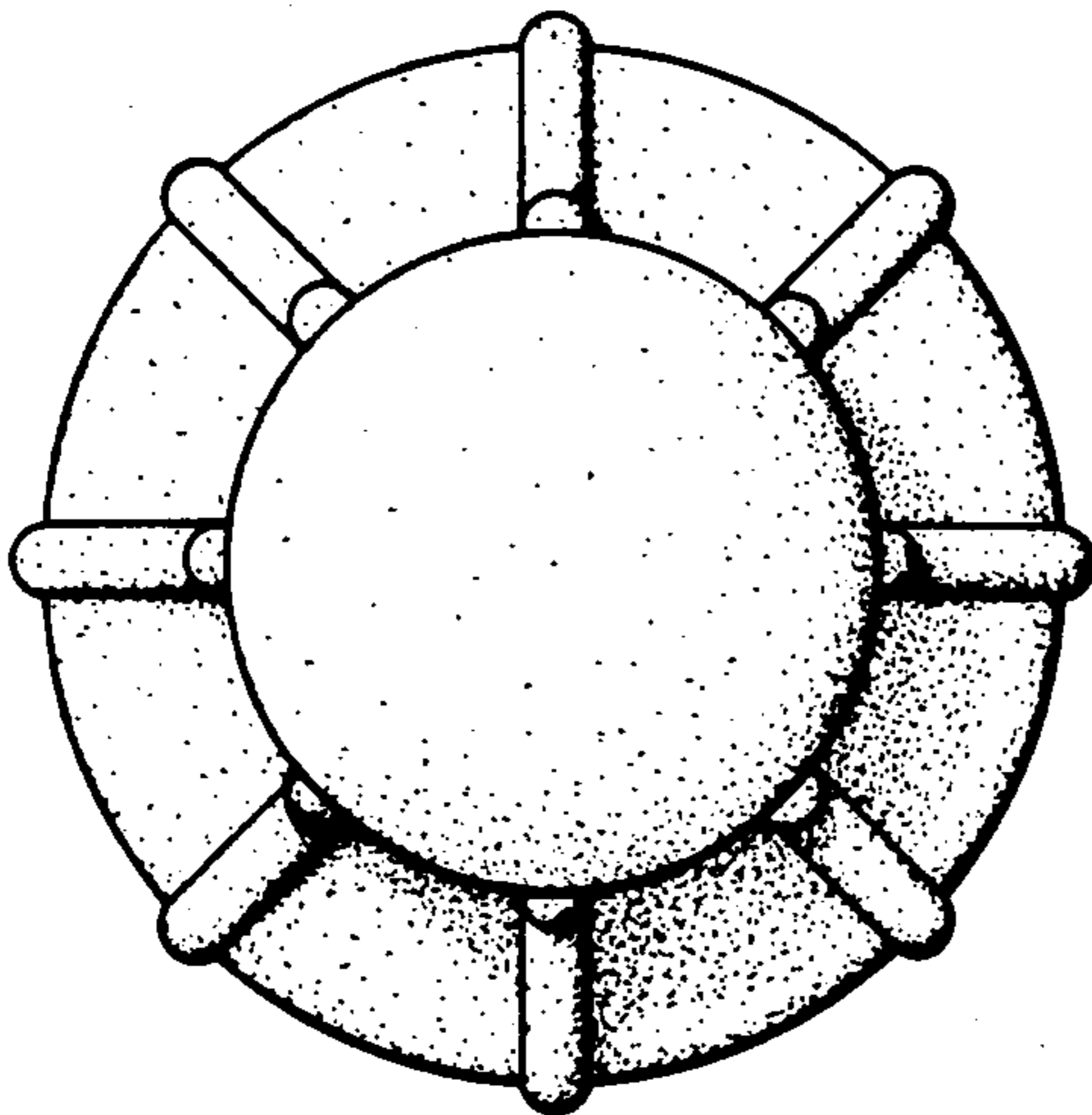

Fig-3

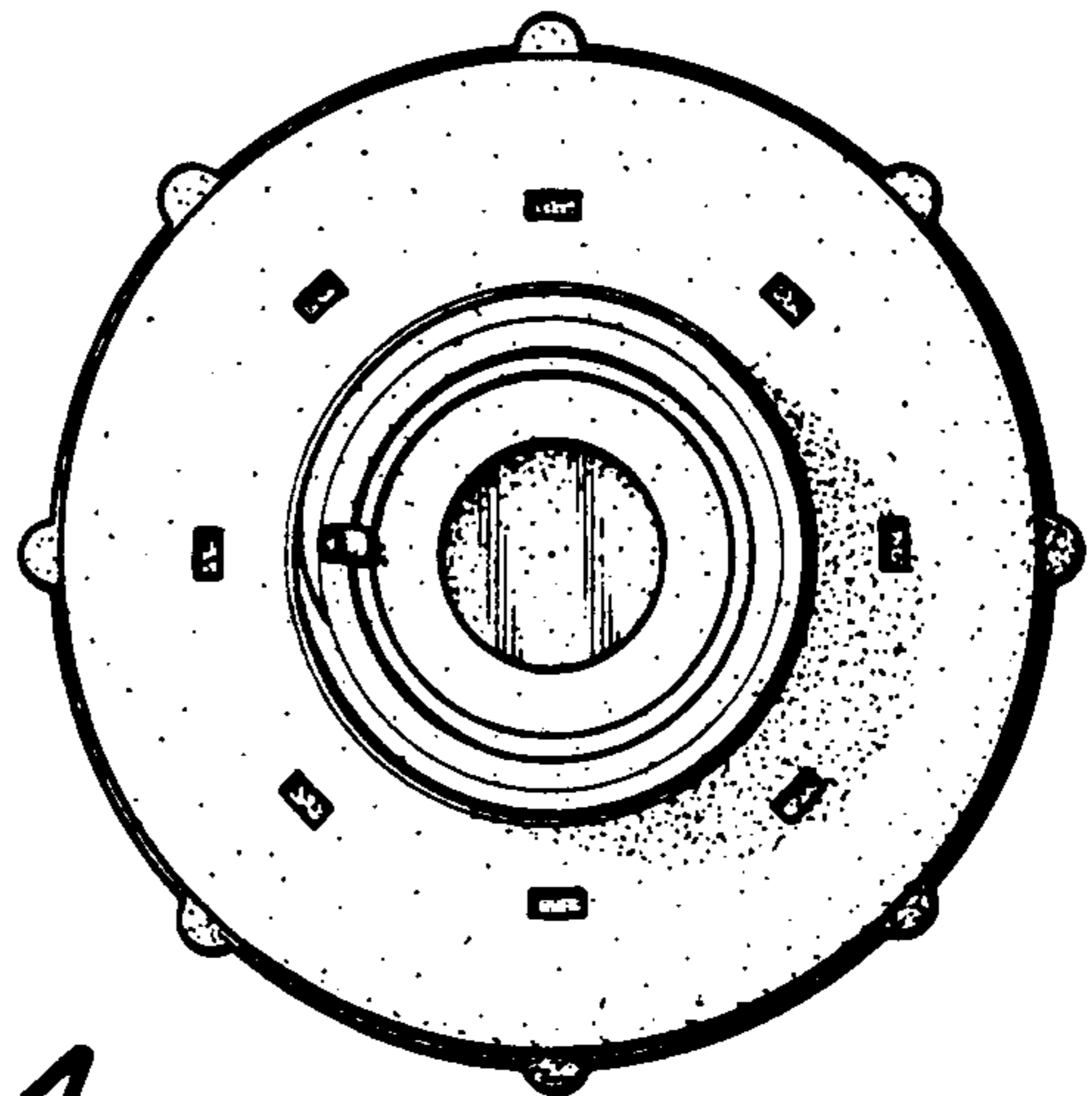

Fig-4