

[54] TREE STAND BOW HOLDER

[76] Inventors: Robert W. Chilcutt, 22 Henderson Dr.; Michael W. Mooney, P.O. Box 1242, Byrd Rd., both of Paris, Tenn. 38242

[\*\*] Term: 14 Years

[21] Appl. No.: 176,376

[22] Filed: Mar. 23, 1988

[52] U.S. Cl. .... D3/38; D6/552; D6/553; D8/355; D8/373

[58] Field of Search ..... D22/199, 107; D3/38; D6/552, 553; D7/631; 211/45, 64, 87, 60, 13; 248/309.1, 214, 296, 122, 126, 176, 187; 124/41.1, 23.1; 42/94; 89/37.04; 182/134, 135, 136, 187; D8/355, 373

[56] References Cited

U.S. PATENT DOCUMENTS

3,286,961 11/1966 Mandolare ..... 248/122

3,953,014 4/1976 Mendell, Jr. .... D7/631 X  
4,360,179 11/1982 Roberts ..... 248/122 X  
4,474,296 10/1984 Hartman ..... 124/23.1 X  
4,542,873 9/1985 Matherly et al. .... 248/309.1 X  
4,729,363 3/1988 Skyba ..... 211/13 X

Primary Examiner—A. Hugo Word  
Assistant Examiner—Doris V. Coles  
Attorney, Agent, or Firm—Walker & McKenzie

[57] CLAIM

The ornamental design for a tree stand bow holder, as shown and described.

DESCRIPTION

FIG. 1 is a front elevational view of a tree stand bow holder showing our new design, the rear elevation being a mirror image thereof;  
FIG. 2 is a right side elevational view thereof, the left side being a mirror image thereof;  
FIG. 3 is a top plan view thereof;  
FIG. 4 is a bottom plan-view thereof; and  
FIG. 5 is an enlarged sectional view as taken on line 5—5 of FIG. 2.

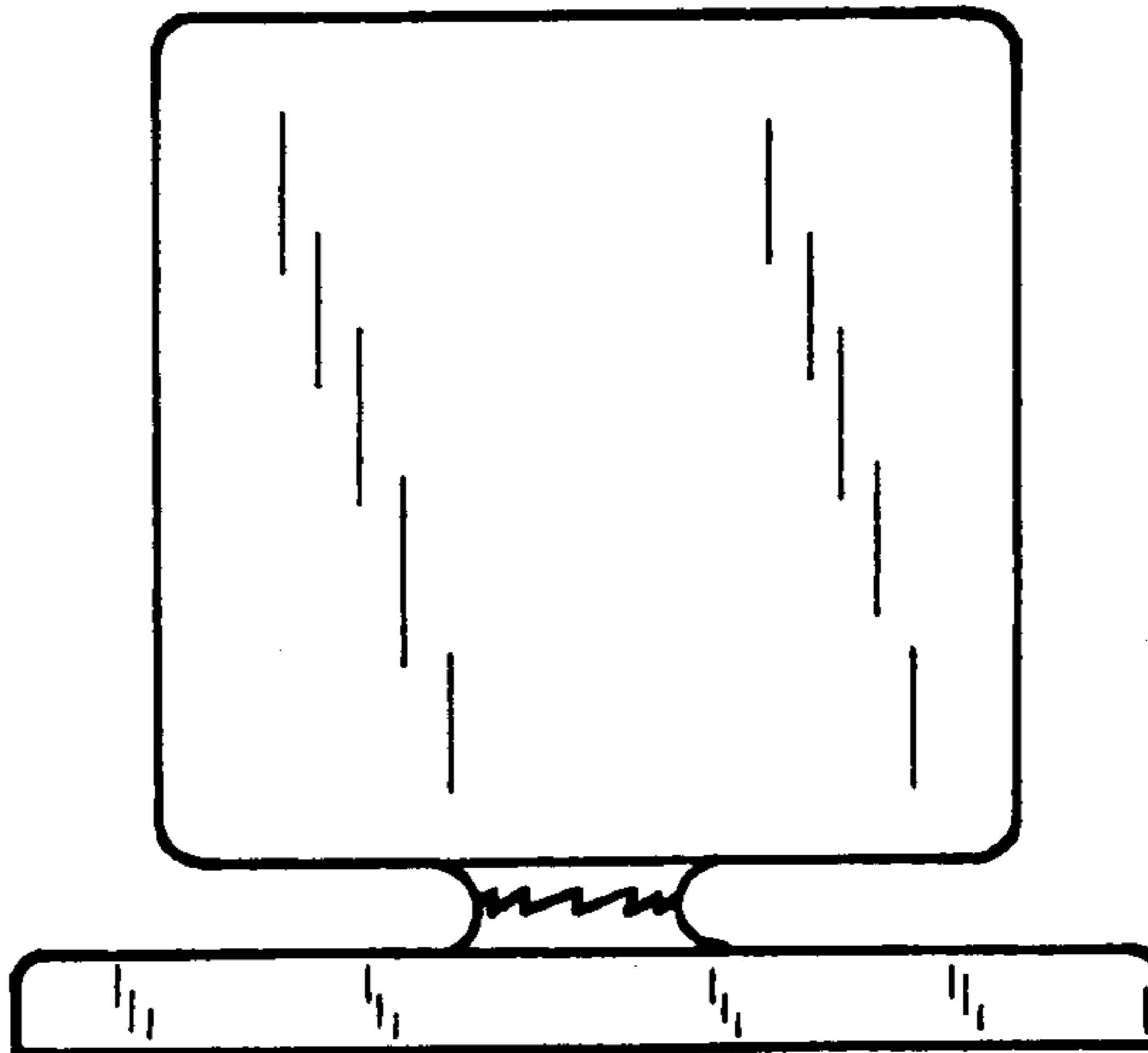

FIG. 1

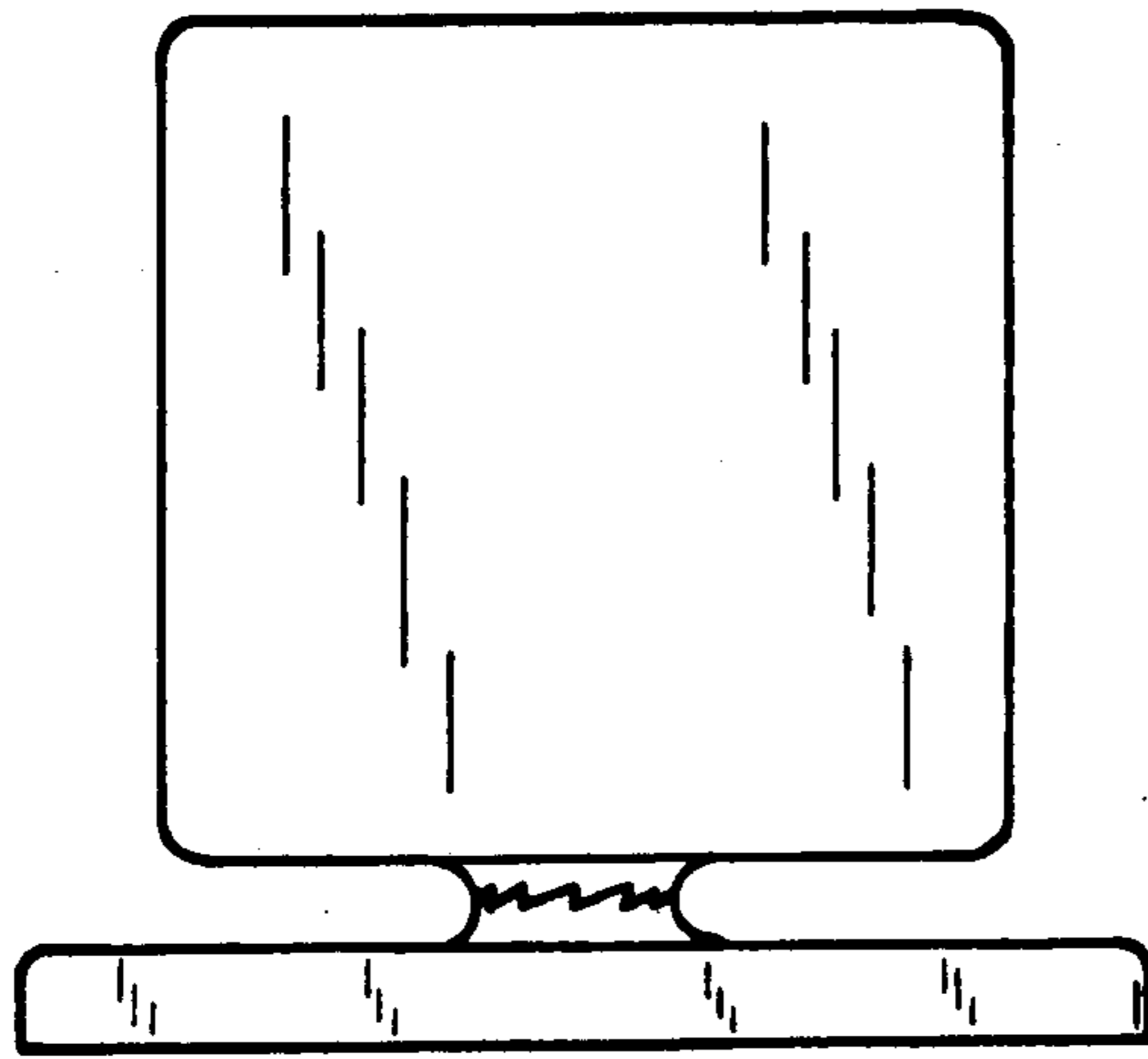

FIG. 2

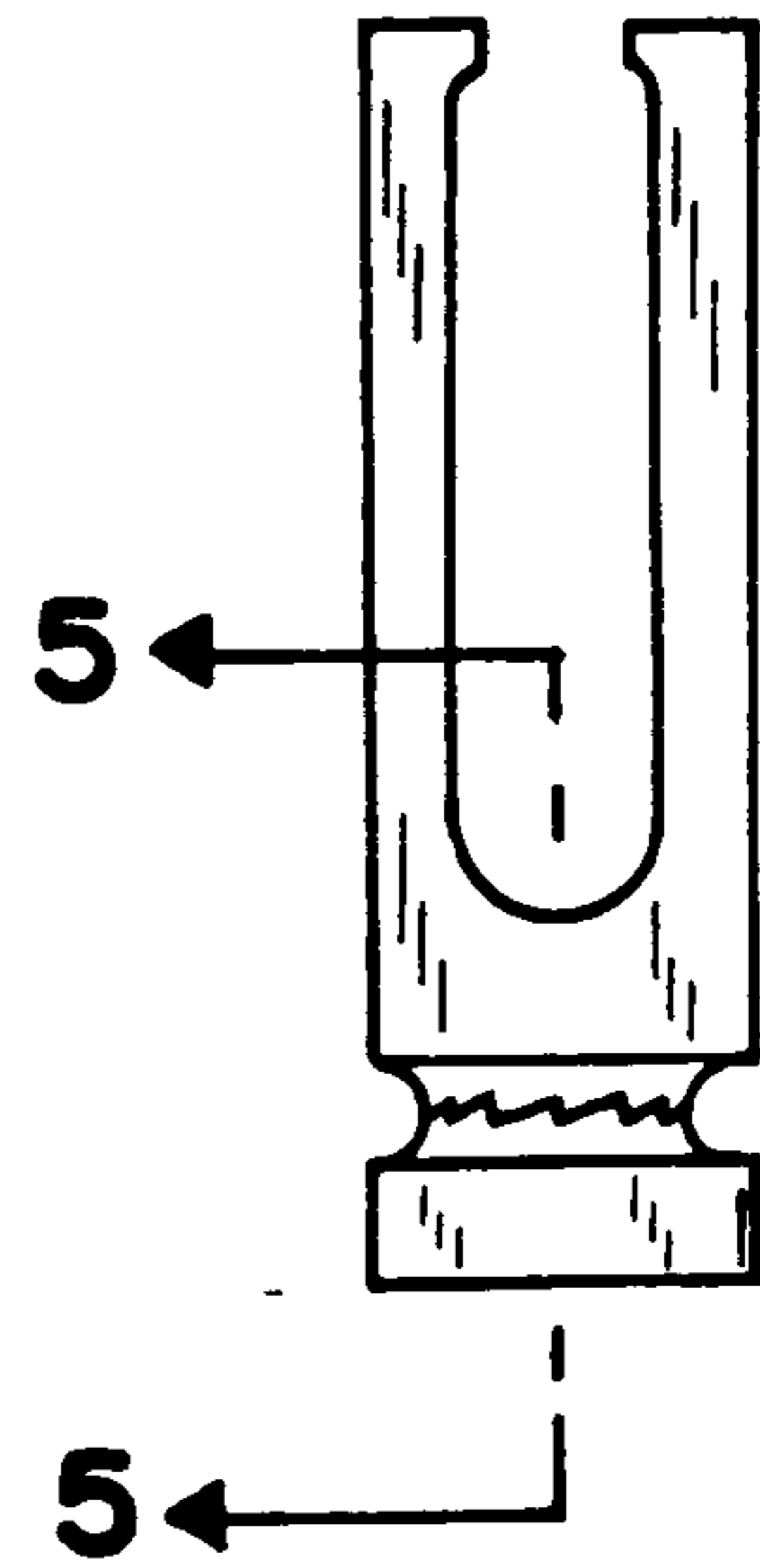

FIG. 3

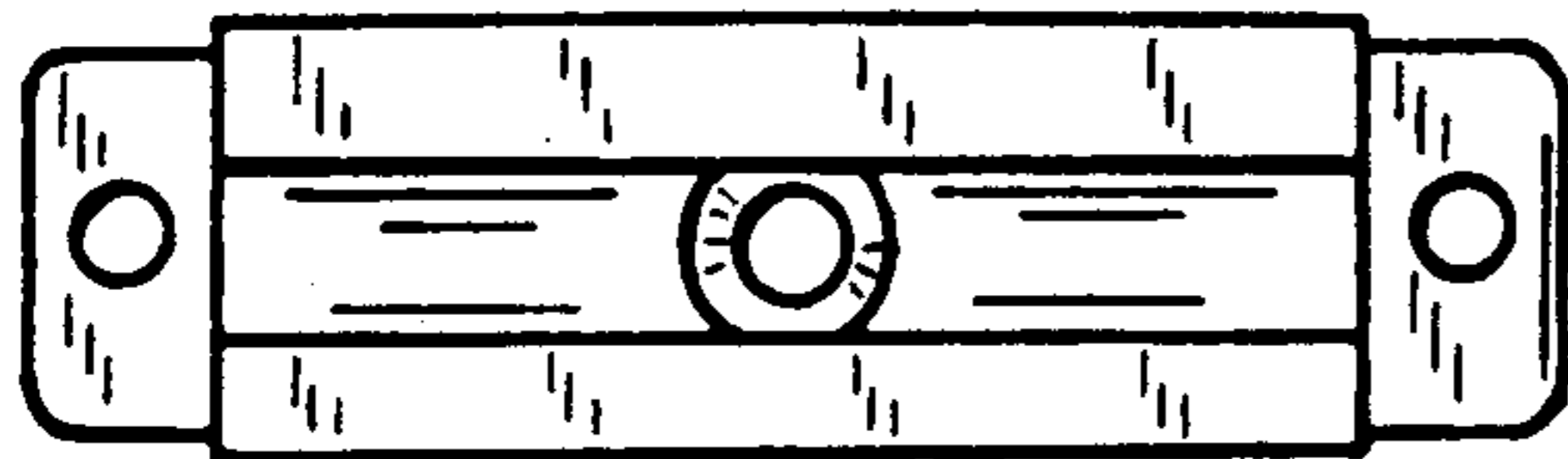

FIG. 4

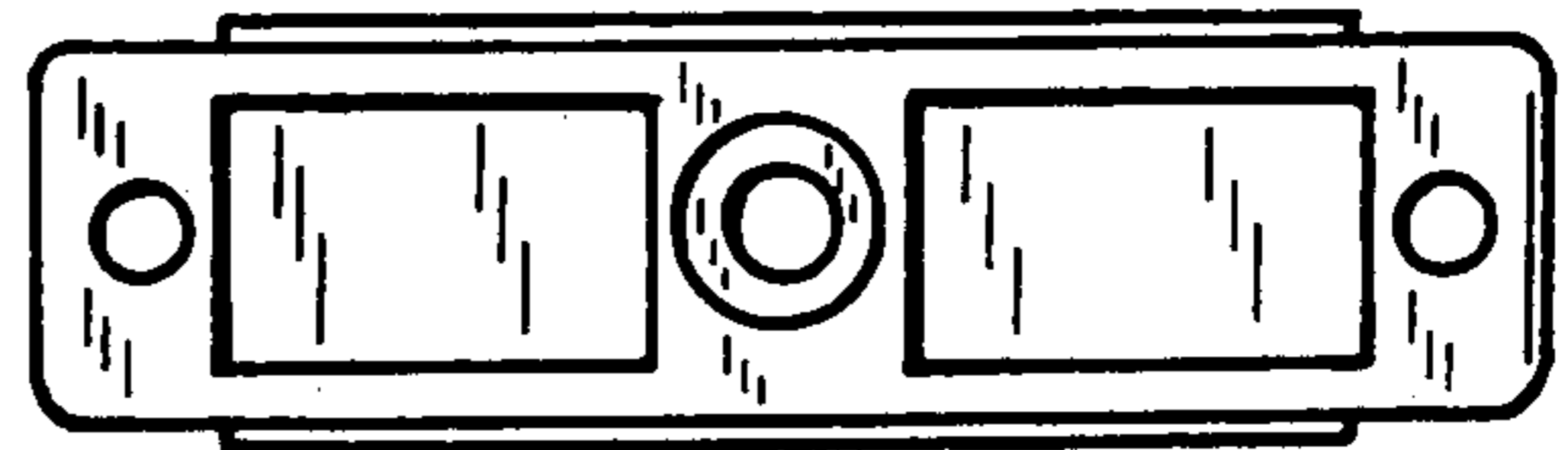

FIG. 5

