

[54] COMBINED VIDEO CAMERA AND A VIDEO CASSETTE RECORDER

[75] Inventor: Kue S. Shim, Seoul, Rep. of Korea

[73] Assignee: Gold Star Co. Ltd., Seoul, Rep. of Korea

[**] Term: 14 Years

[21] Appl. No.: 365,026

[22] Filed: Jun. 9, 1989

[30] Foreign Application Priority Data

Dec. 22, 1988 [KR] Rep. of Korea 17447/1988

[52] U.S. Cl. D16/202

[58] Field of Search D16/200, 202, 205, 208; 352/34, 242, 243; 354/82, 293; 358/229, 906

[56] References Cited

U.S. PATENT DOCUMENTS

| | | | | |
|------------|---------|--------------|-------|---------|
| D. 285,683 | 9/1986 | Shibata | | D16/202 |
| D. 289,893 | 5/1987 | Takemoto | | D16/202 |
| D. 298,134 | 10/1988 | Mori | | D16/202 |
| 4,623,931 | 11/1986 | Inaga et al. | | 358/229 |

OTHER PUBLICATIONS

Video Review, Dec. 1985, p. 104 (Pentax PV-C11A Camcorder).

Video Review, Dec. 1986, p. 20 (Canon VM-E1 Camcorder).

Video Review, Mar. 1988, p. 68 (Pentax PV-C1SA Camcorder).

Popular Photography, Mar. 1989, p. 50 (Olympus VX-406 & JVC GR-S707U Camcorders).

Primary Examiner—B. J. Bullock

Assistant Examiner—Adir Aronovich

Attorney, Agent, or Firm—John P. White

[57] CLAIM

The ornamental design for a combined video camera and video cassette, as shown.

DESCRIPTION

FIG. 1 is a top, front and right side perspective view of a combined video camera and video cassette showing my new design;

FIG. 2 is a top plan view thereof;

FIG. 3 is a bottom plan view thereof;

FIG. 4 is a front elevational view thereof;

FIG. 5 is a rear elevational view thereof;

FIG. 6 is a right side elevational view thereof; and

FIG. 7 is a left side elevational view thereof.

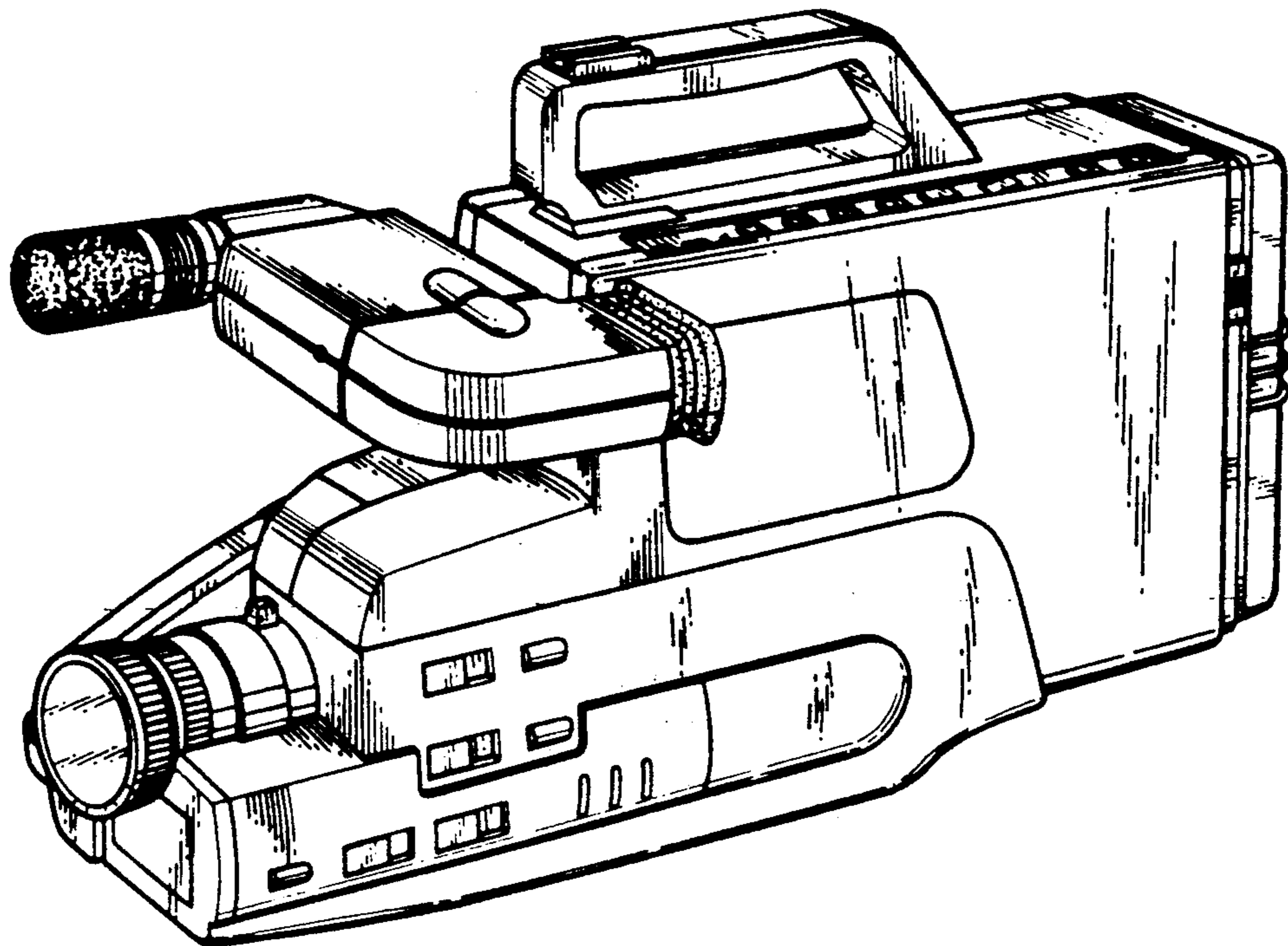

F I G . 1

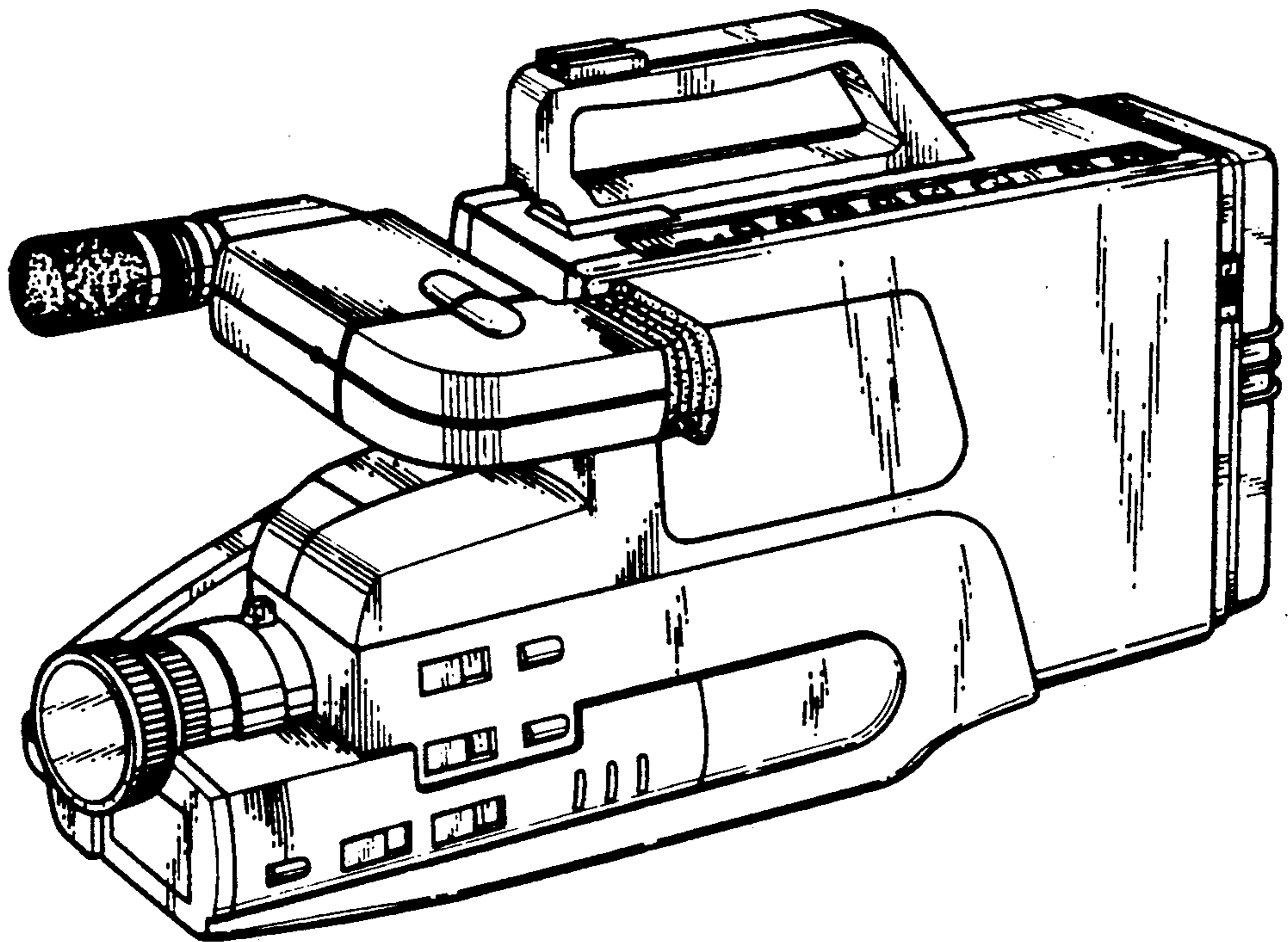

F I G . 2

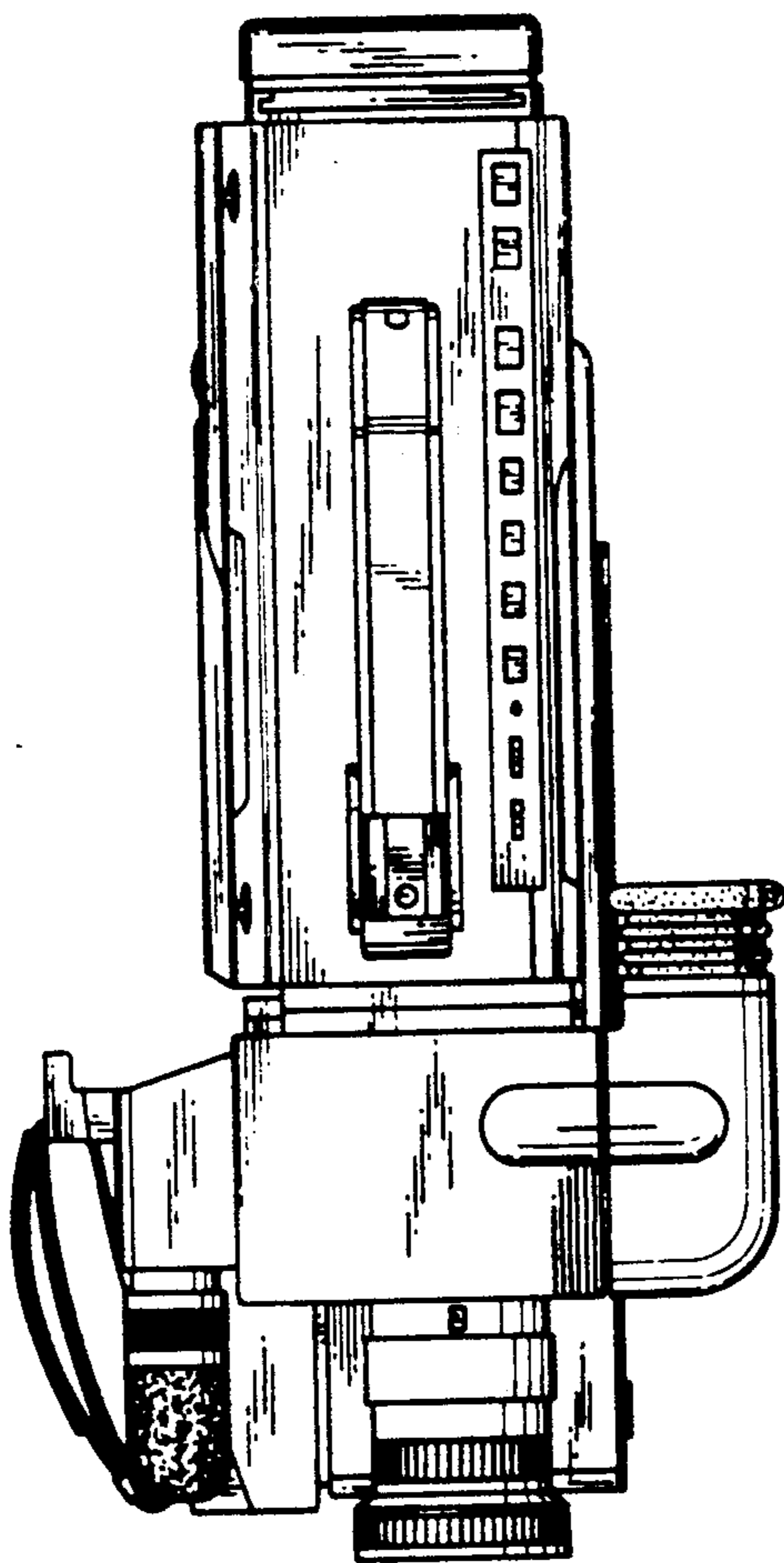

F I G . 3

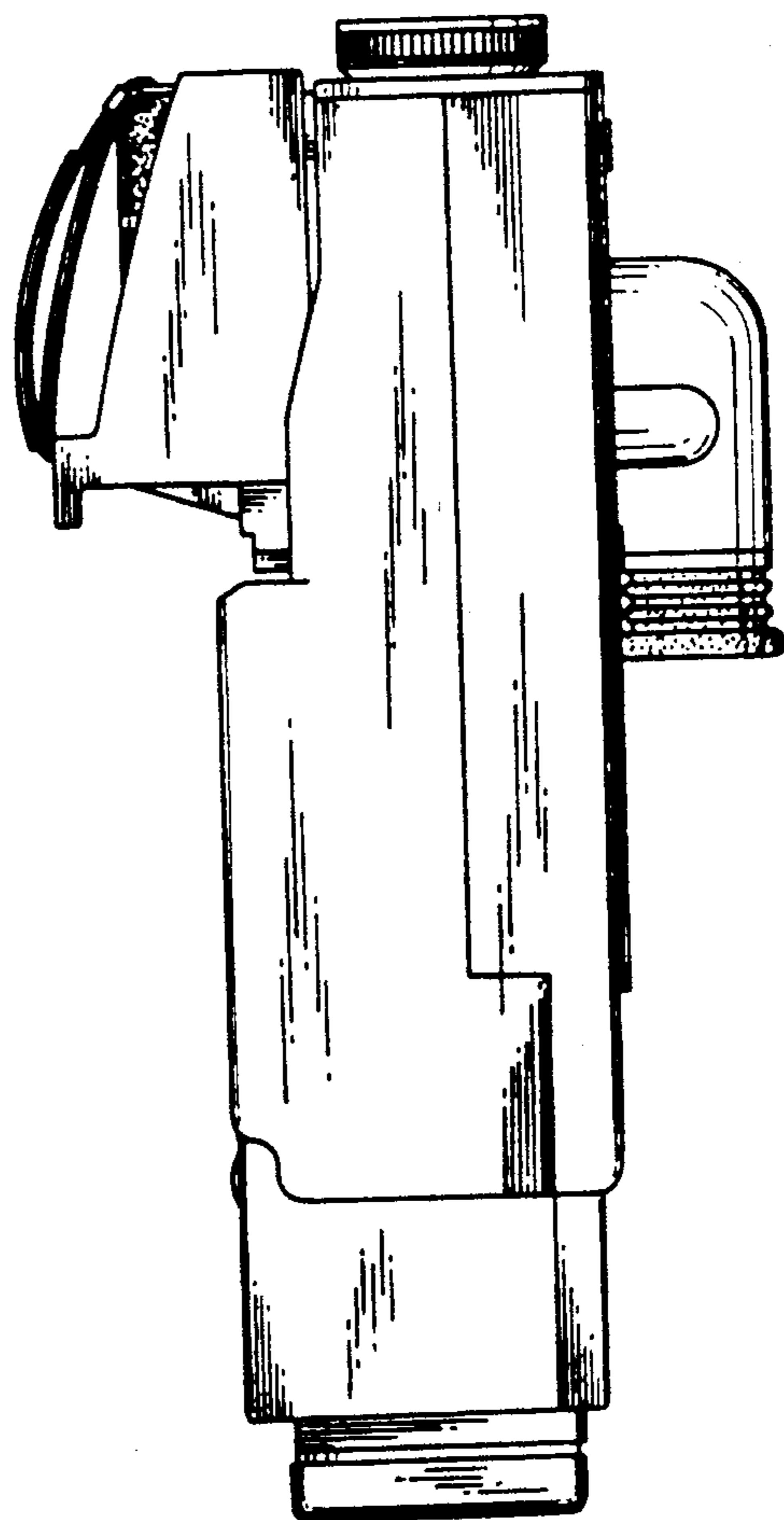

F I G . 4

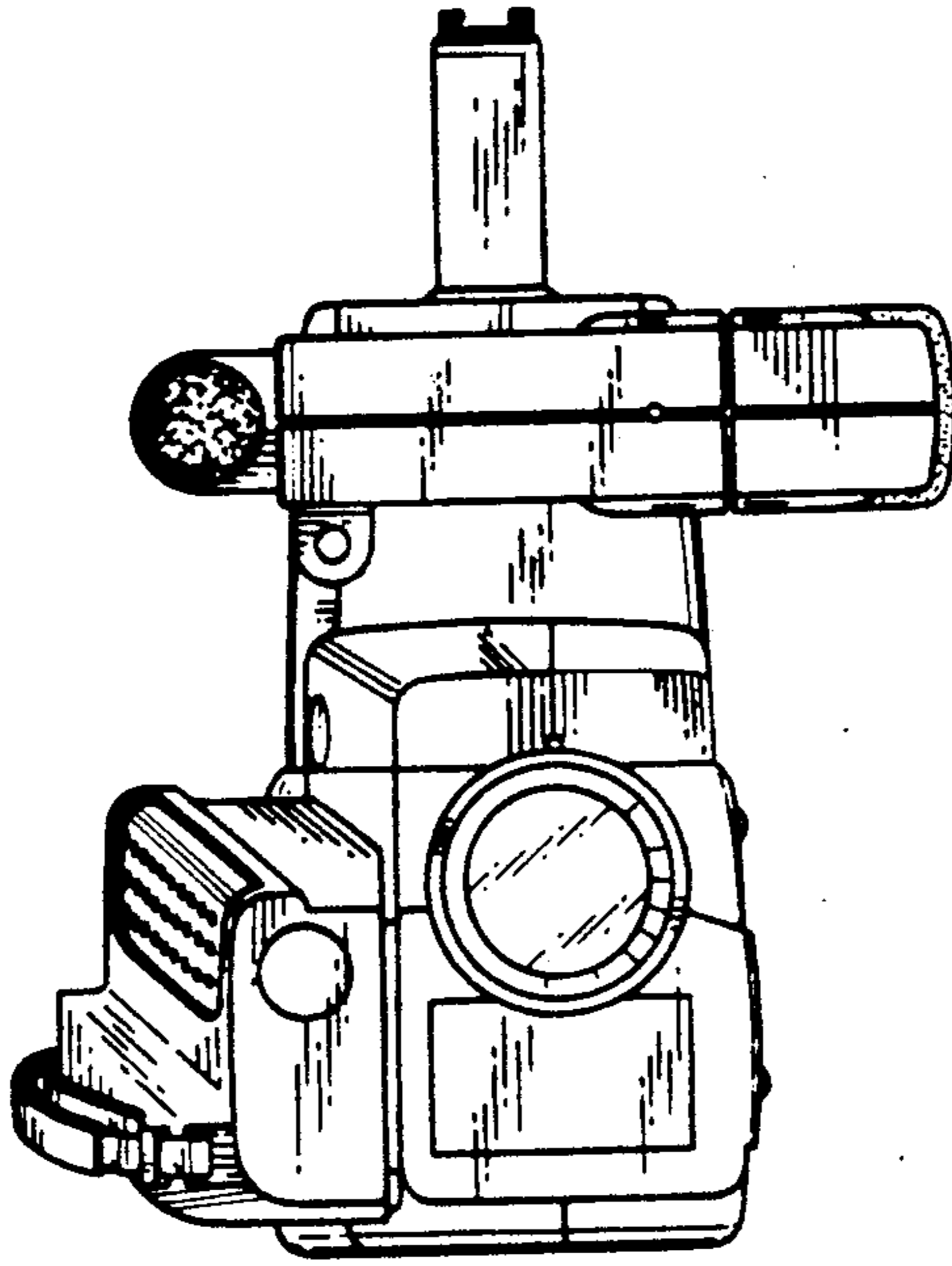

F I G . 5

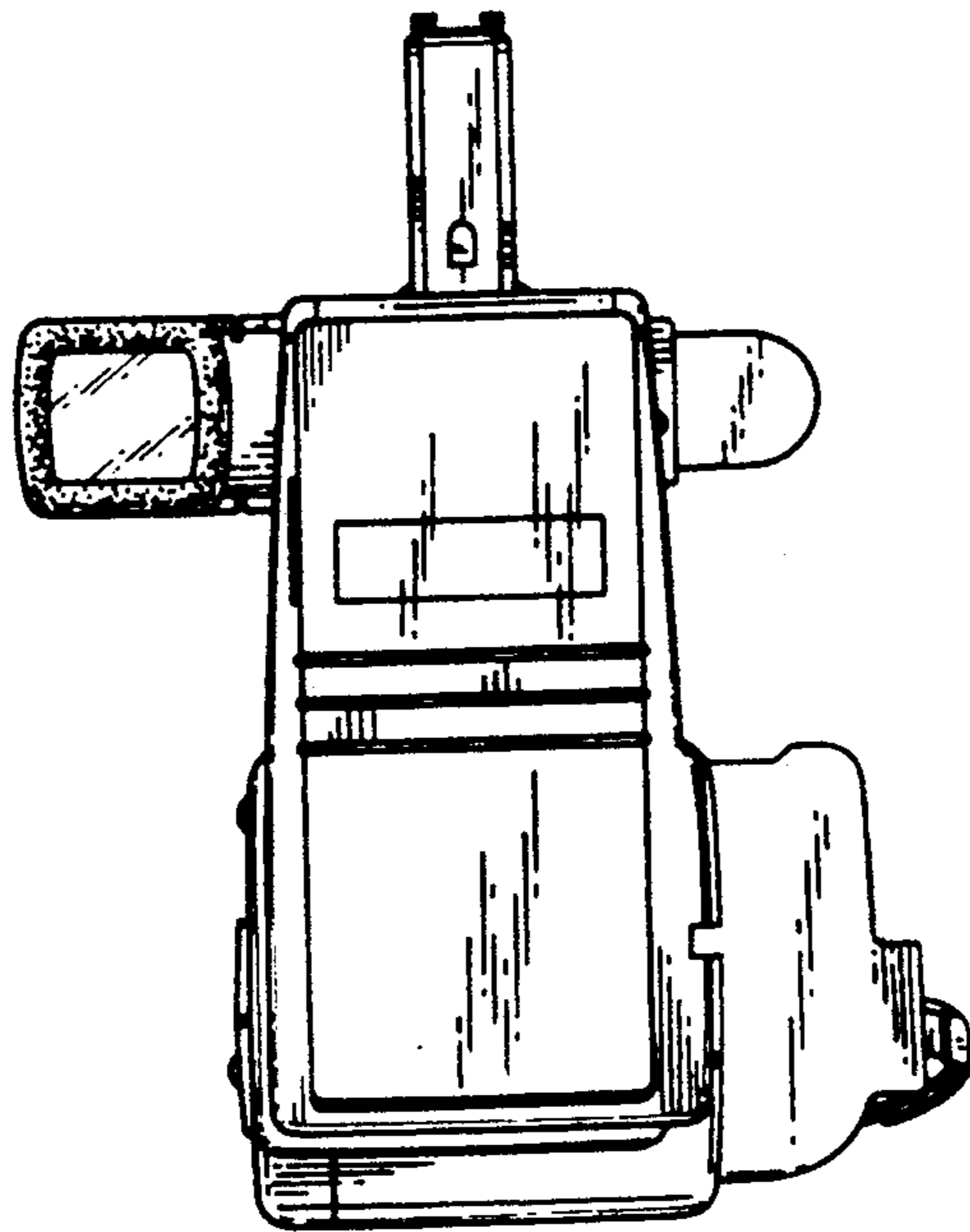

F I G . 6

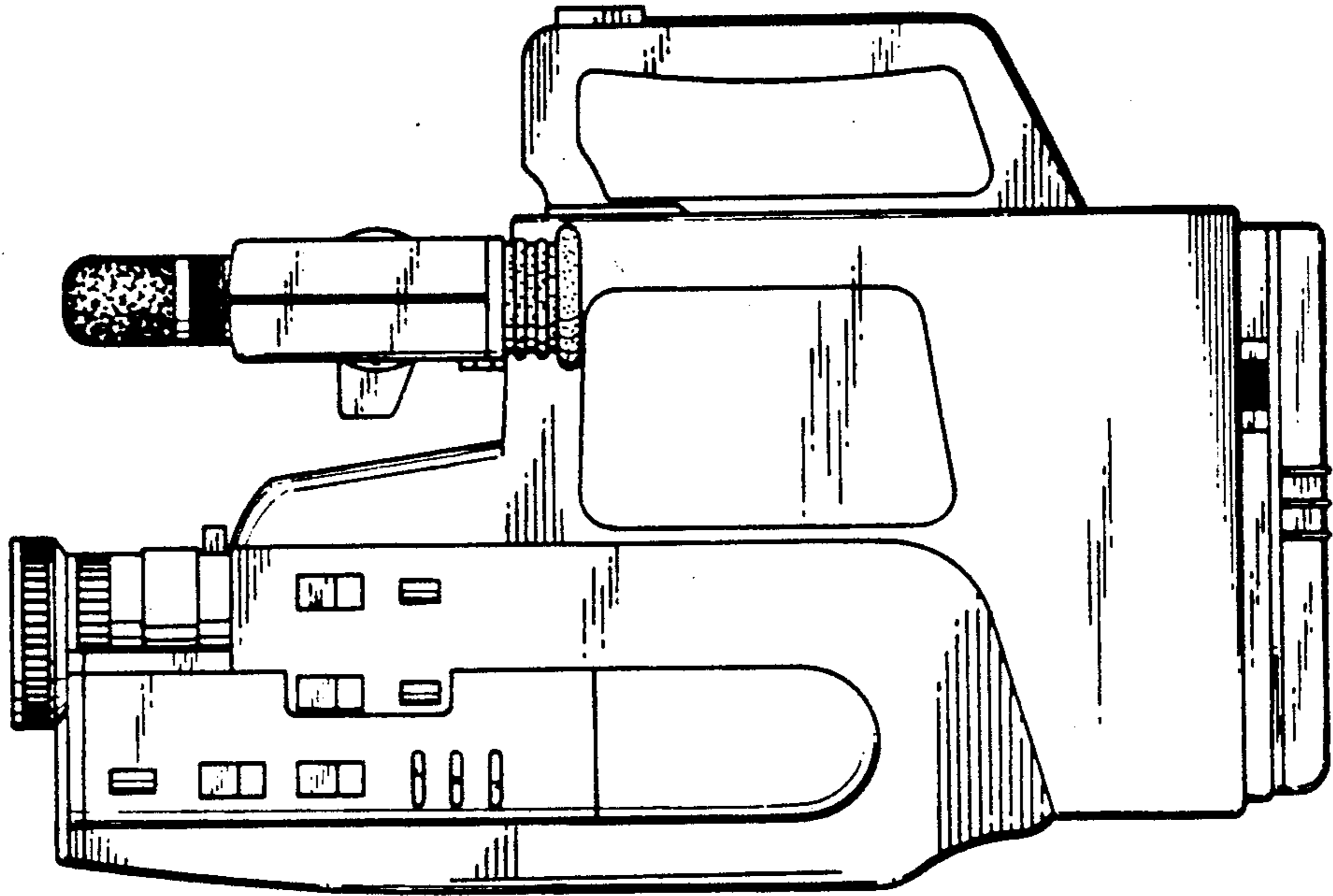

F I G . 7

