

[54] AMBIENT AIR IMPELLER FOR IGNITING BRIQUETS, OR THE LIKE

[76] Inventor: Christopher D. Williams, 14019 Calmont Dr., Houston, Tex. 77070

[**] Term: 14 Years

[21] Appl. No.: 202,443

[22] Filed: Jun. 6, 1988

4,668,855 5/1987 Wilson et al. 34/96 X

OTHER PUBLICATIONS

Hong Kong Enterprise, Sep. 1985, p. 213, Item "I" (Turbo Driver).

Primary Examiner—A. Hugo Word
Assistant Examiner—Doris V. Coles
Attorney, Agent, or Firm—Pravel, Gambrell, Hewitt, Kimball & Krieger

Related U.S. Application Data

[63] Continuation-in-part of Ser. No. 33,255, Apr. 2, 1987.

[52] U.S. Cl. D7/416

[58] Field of Search D15/7; D7/416; D28/13, D28/16; D8/14.1; 417/411, 234; 34/96, 97; 132/271; 126/25 B

[57] CLAIM

The ornamental design for an ambient air impeller for igniting briquets or the like, as shown and described.

DESCRIPTION

FIG. 1 is a top plan view of an ambient air impeller, for igniting briquets, or the like showing my new design; FIG. 2 is a bottom plan view thereof; FIG. 3 is a front elevational view thereof; FIG. 4 is a rear elevational view thereof; FIG. 5 is a side elevational view thereof; FIG. 6 is a side elevational fragmented view of the handle of the claimed design, with the hook extended; and FIG. 7 is a rear elevational view of an alternative rear embodiment.

[56] References Cited

U.S. PATENT DOCUMENTS

- D. 276,941 12/1984 Stansbury, Jr. D28/13
- D. 279,124 6/1985 Jensen et al. D7/416
- D. 281,360 11/1985 Wistrand D28/13
- D. 283,259 4/1986 Stansbury, Jr. D28/13
- D. 290,681 7/1987 Pudwill D8/14.1
- 4,044,750 8/1977 Zeigler 417/411 X
- 4,551,615 11/1985 Wilson 34/96 X

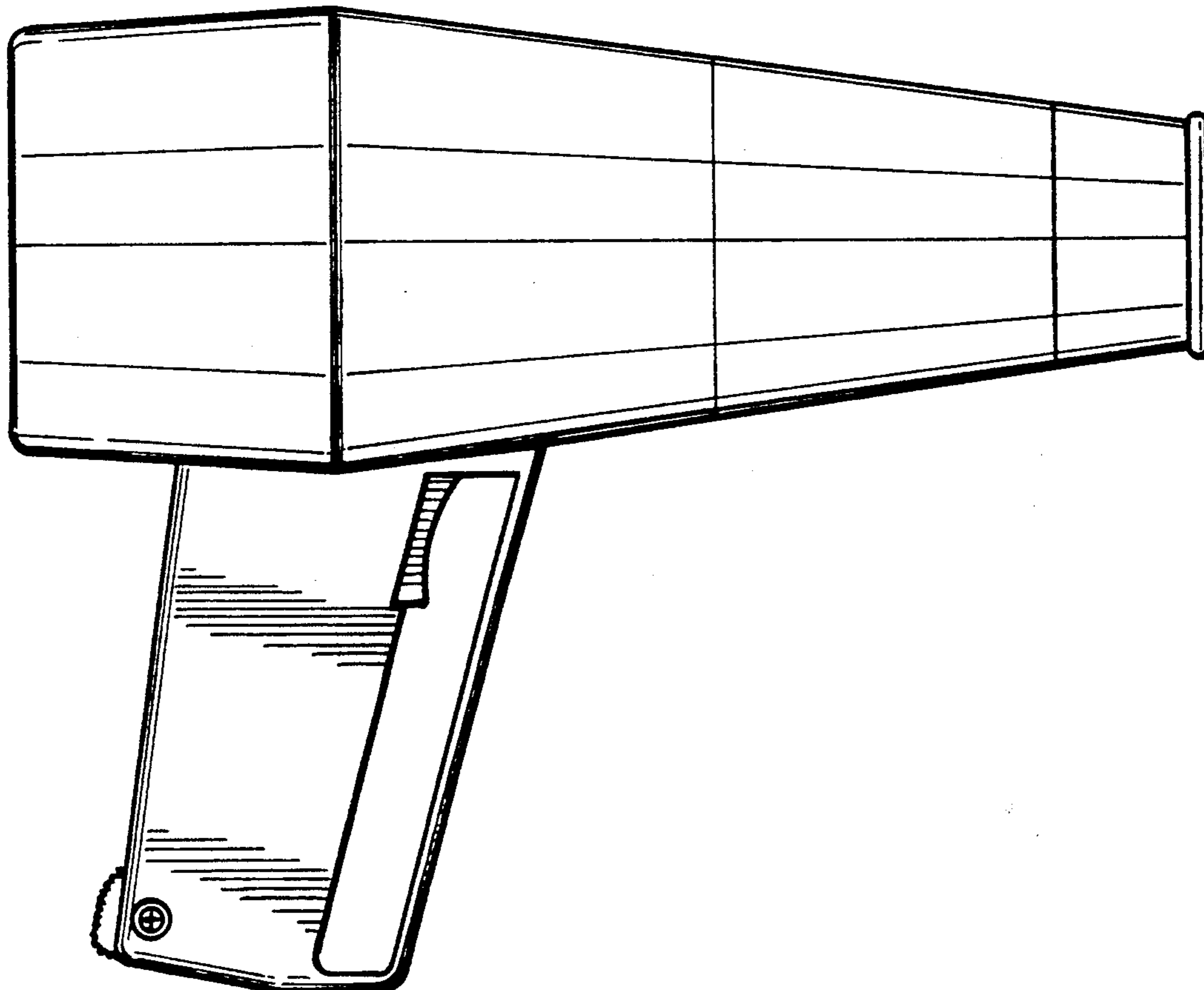

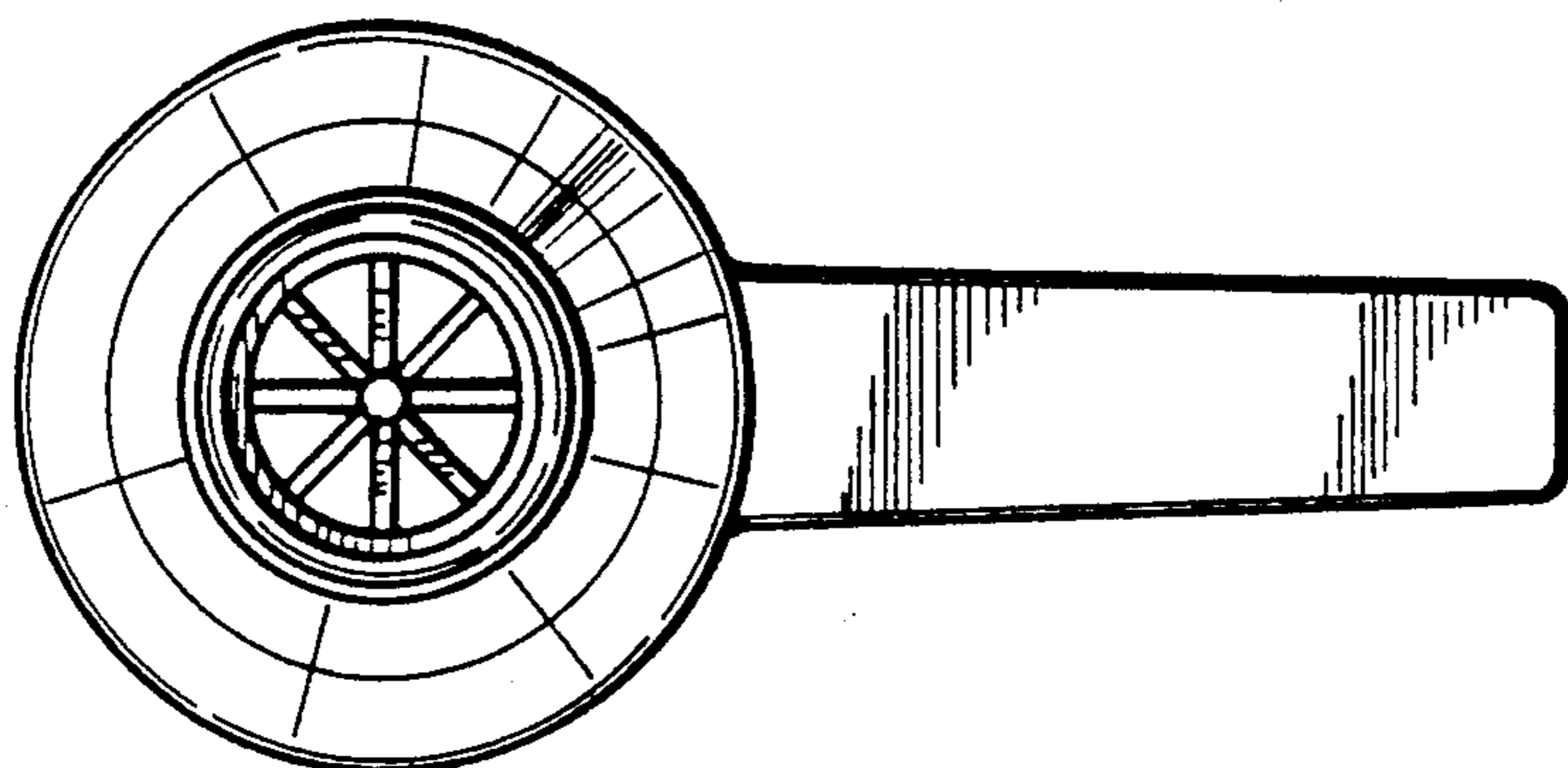

FIG 3

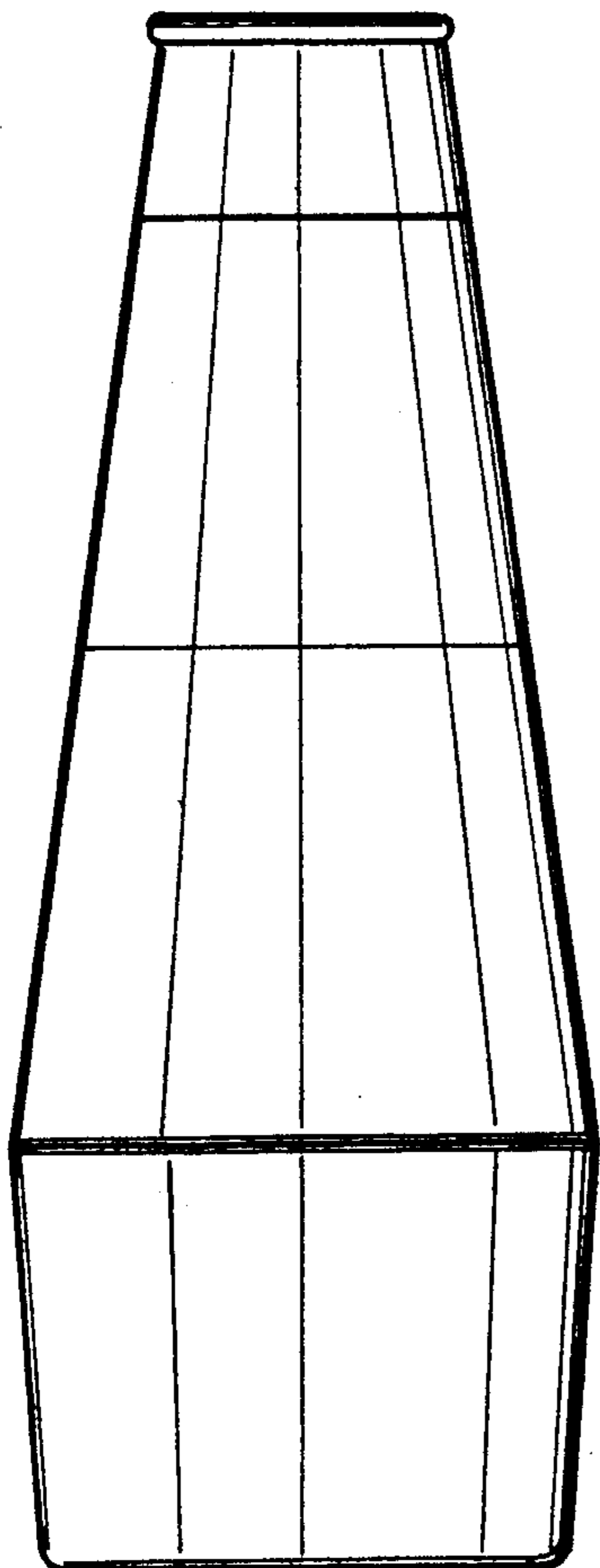

FIG 1

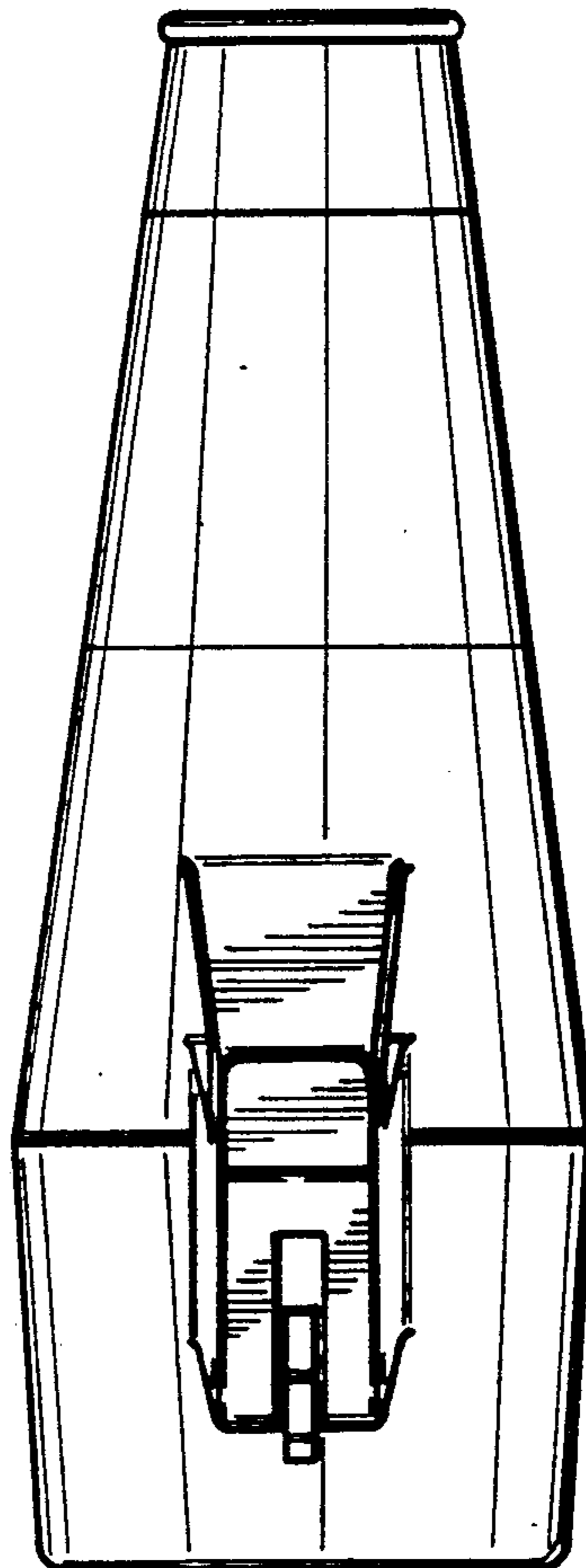

FIG 2

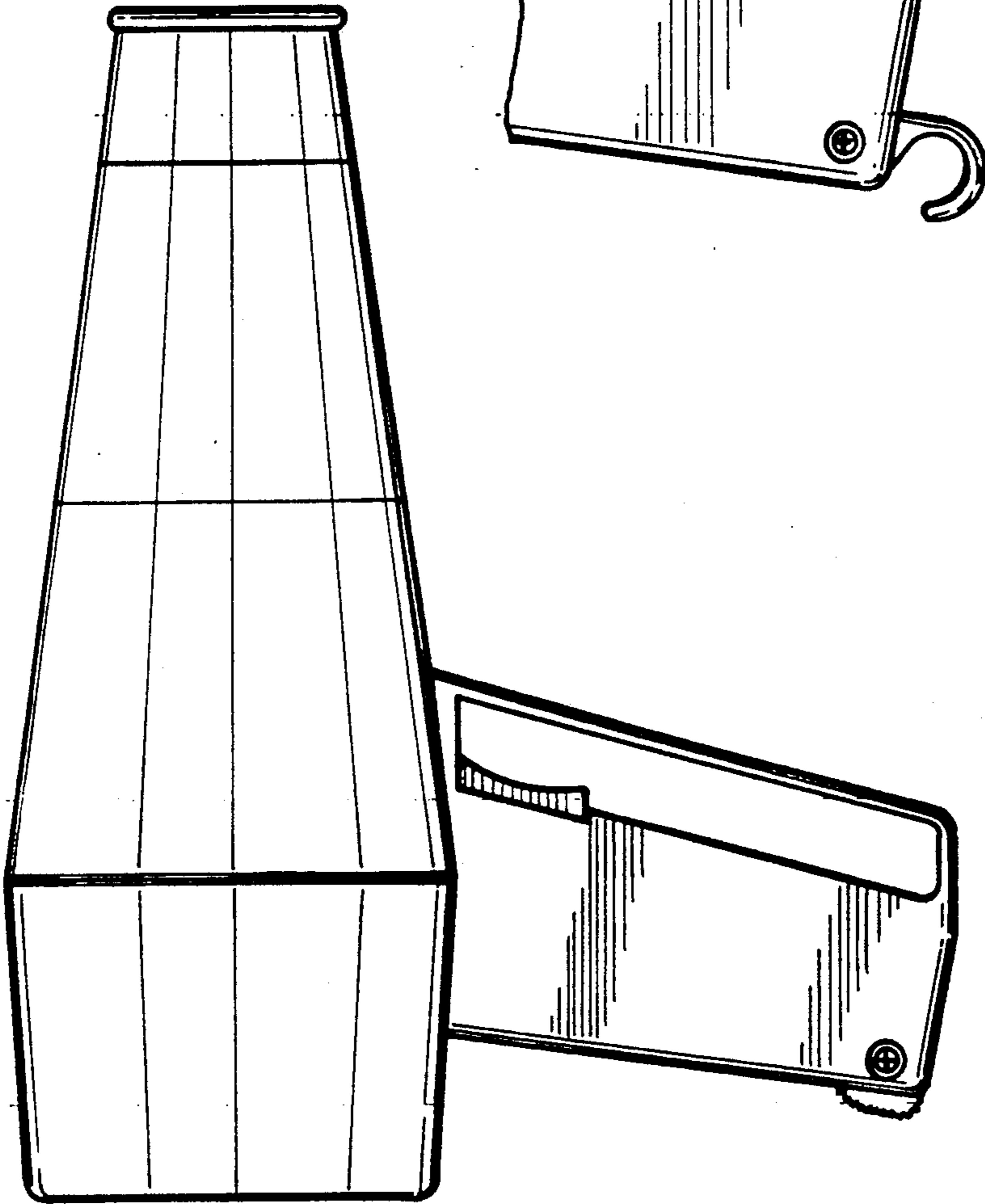

FIG 5

FIG 6

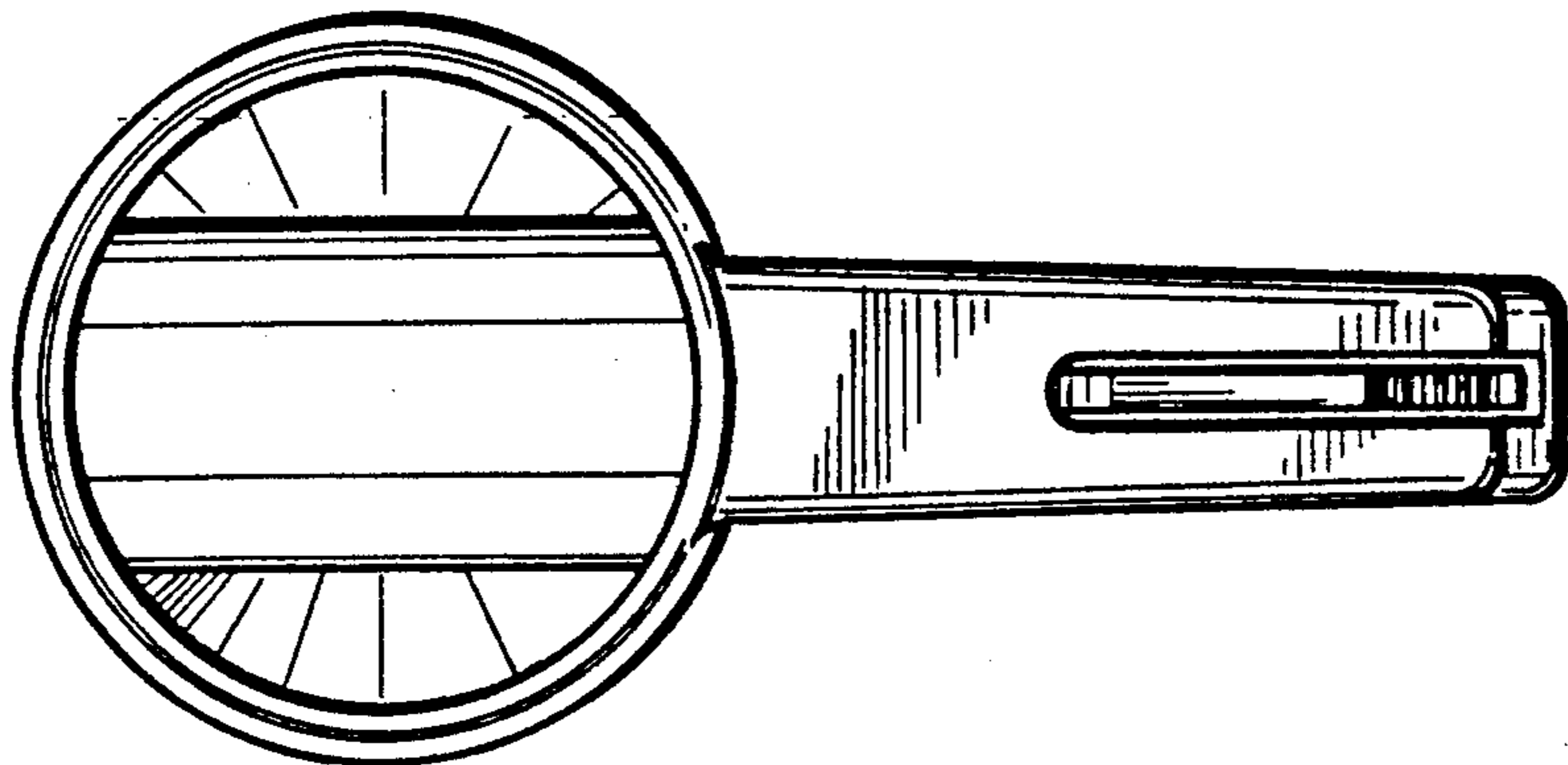

FIG 4

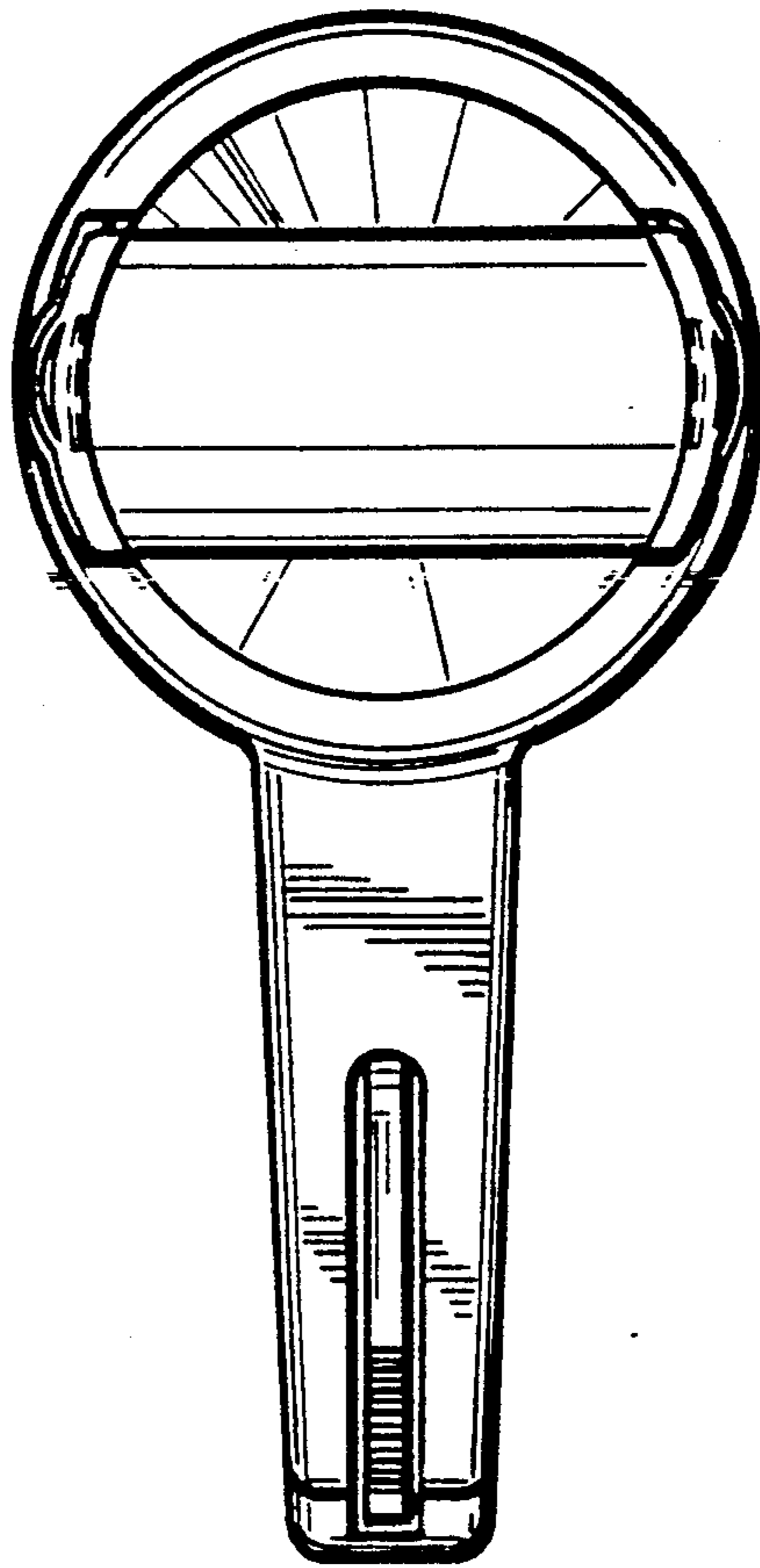

FIG 7