

[54] TOY RACING CAR

[75] Inventor: Hiroyuki Yoshino, Shizuoka, Japan

[73] Assignee: Kabushiki Kaisha Tamiya Mokei, Japan

[\*\*] Term: 14 Years

[21] Appl. No.: 393,770

[22] Filed: Aug. 15, 1989

[52] U.S. Cl. .... D21/137

[58] Field of Search ..... D21/136, 137; D12/88, D12/86; 446/470, 471, 454, 456, 444, 446

[56] References Cited

PUBLICATIONS

Hong Kong Toys '88 p. 86 lower right.  
Hong Kong Toys '88 p. 706, bottom.

Model BXPO Winter 1986-87, p. 3, middle Vehicle Digest.

Primary Examiner—Charles A. Rademaker  
Assistant Examiner—Raphael Barkai  
Attorney, Agent, or Firm—Finnegan, Henderson, Farabow, Garrett & Dunner

[57] CLAIM

The ornamental design for a toy racing car, as shown and described.

DESCRIPTION

FIG. 1 is a perspective view of a toy racing car showing my new design;  
FIG. 2 is a front elevational view thereof;  
FIG. 3 is a rear elevational view thereof;  
FIG. 4 is a top plan view thereof;  
FIG. 5 is a bottom plan view thereof;  
FIG. 6 is a right side elevational view thereof; and  
FIG. 7 is a left side elevational view thereof.

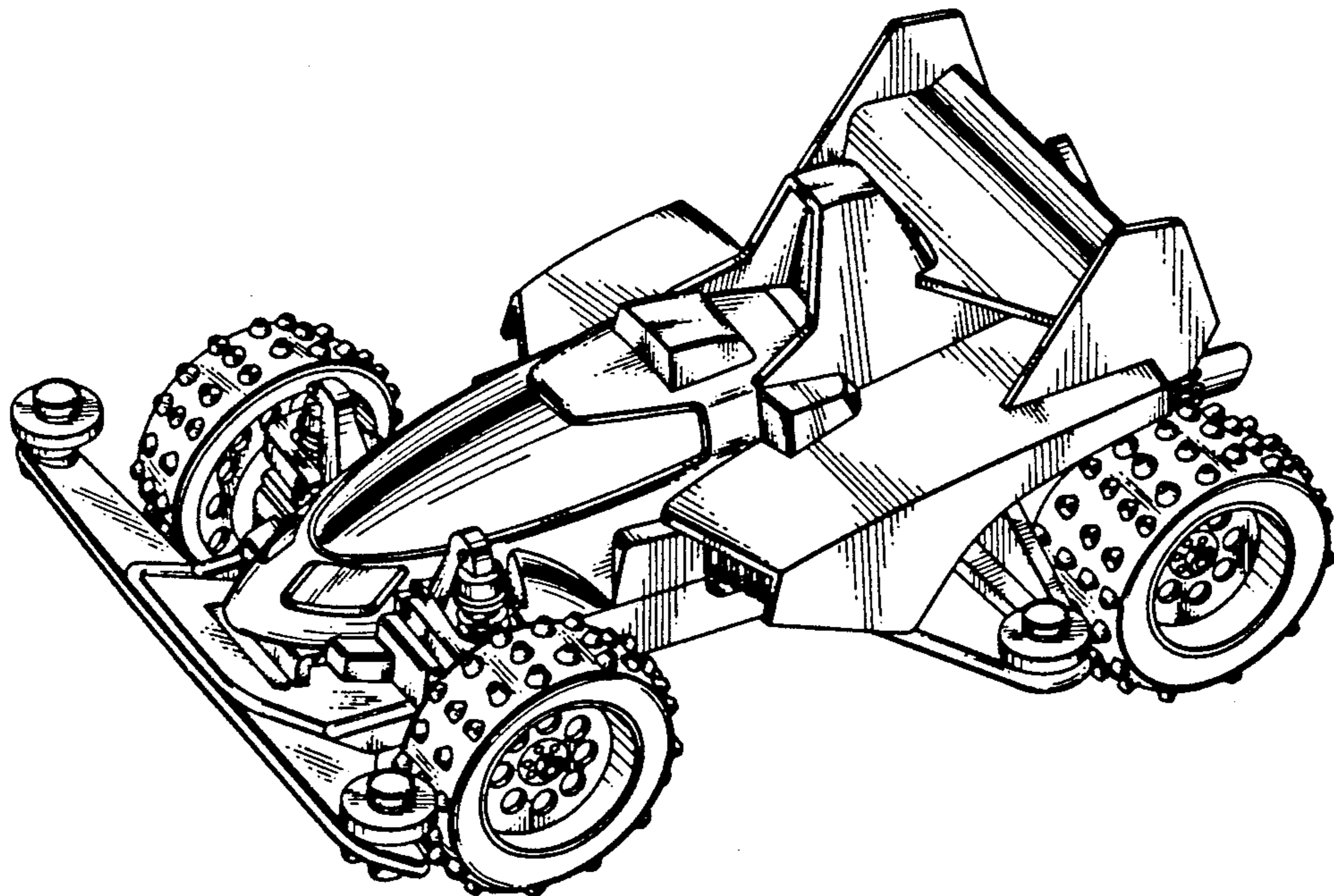

FIG. 1

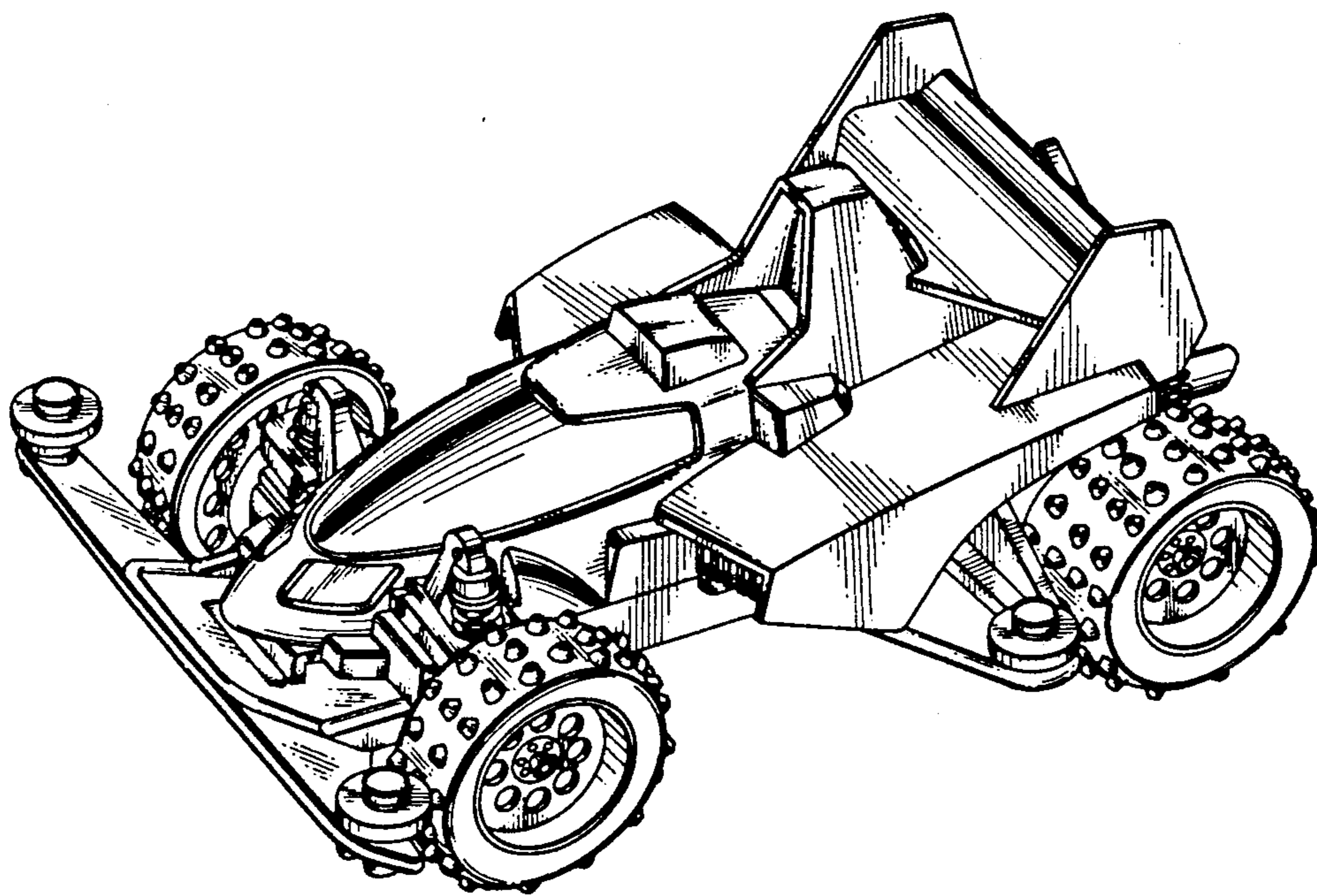

FIG. 2

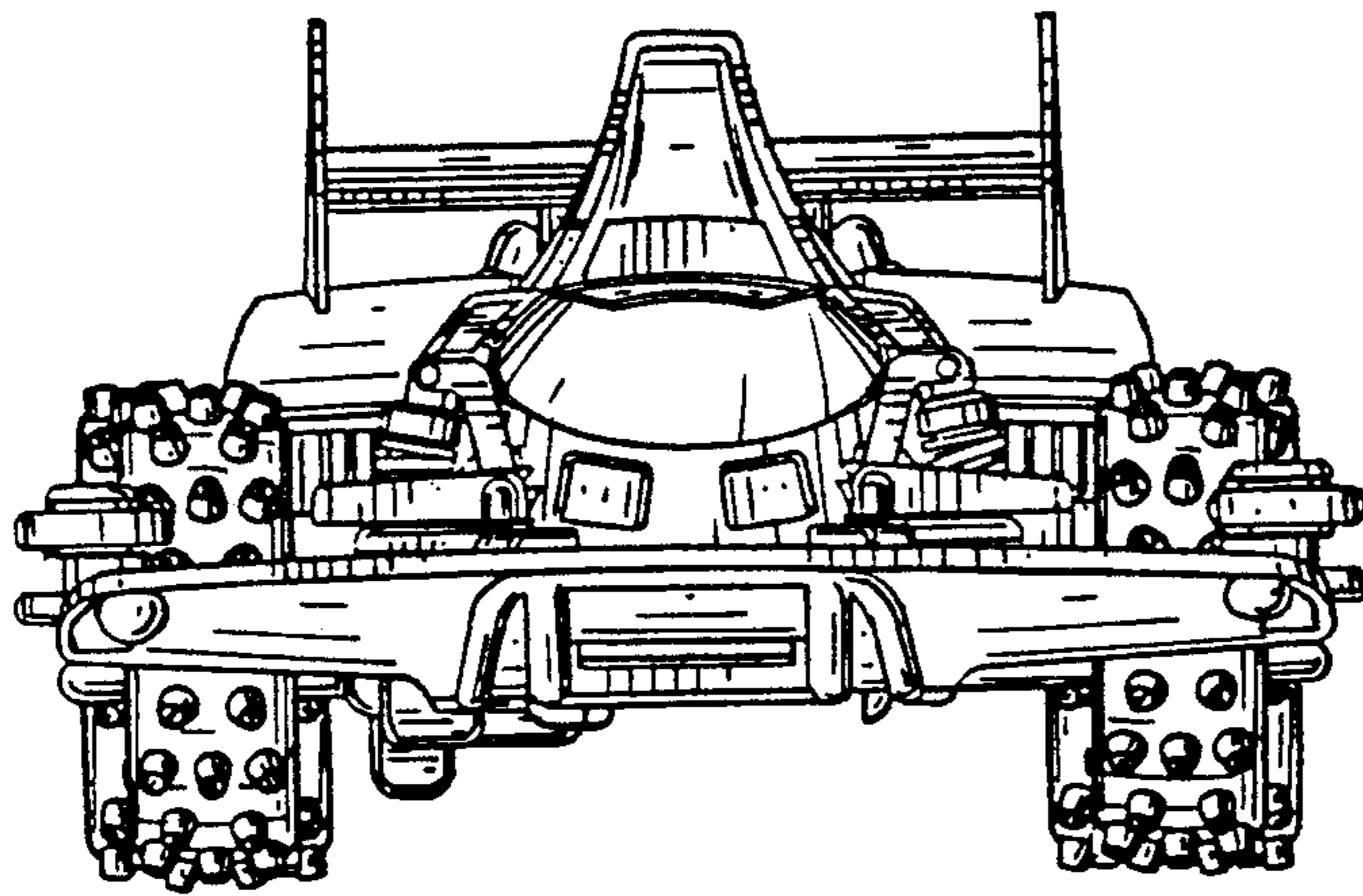

FIG. 3

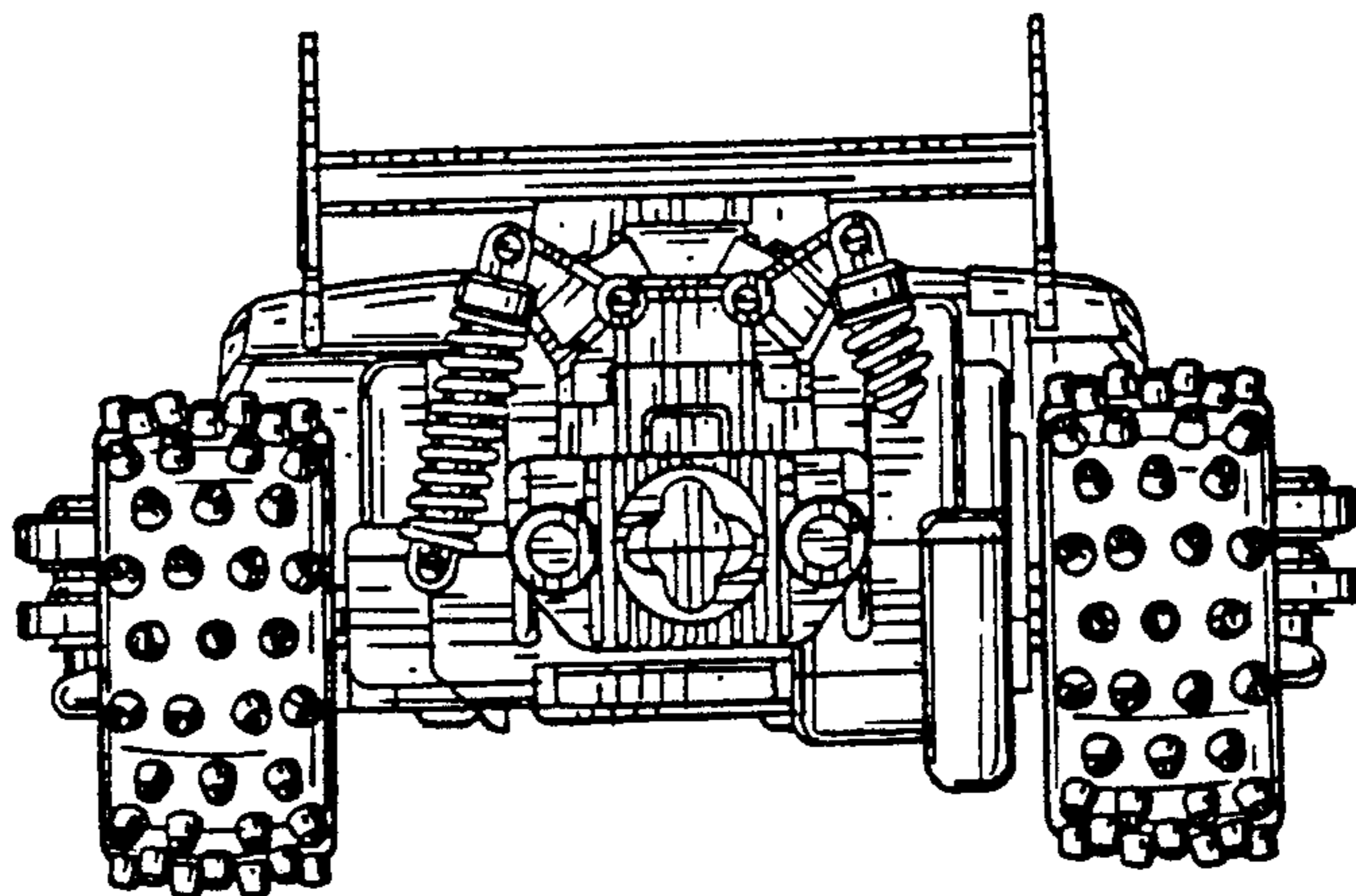

FIG. 4

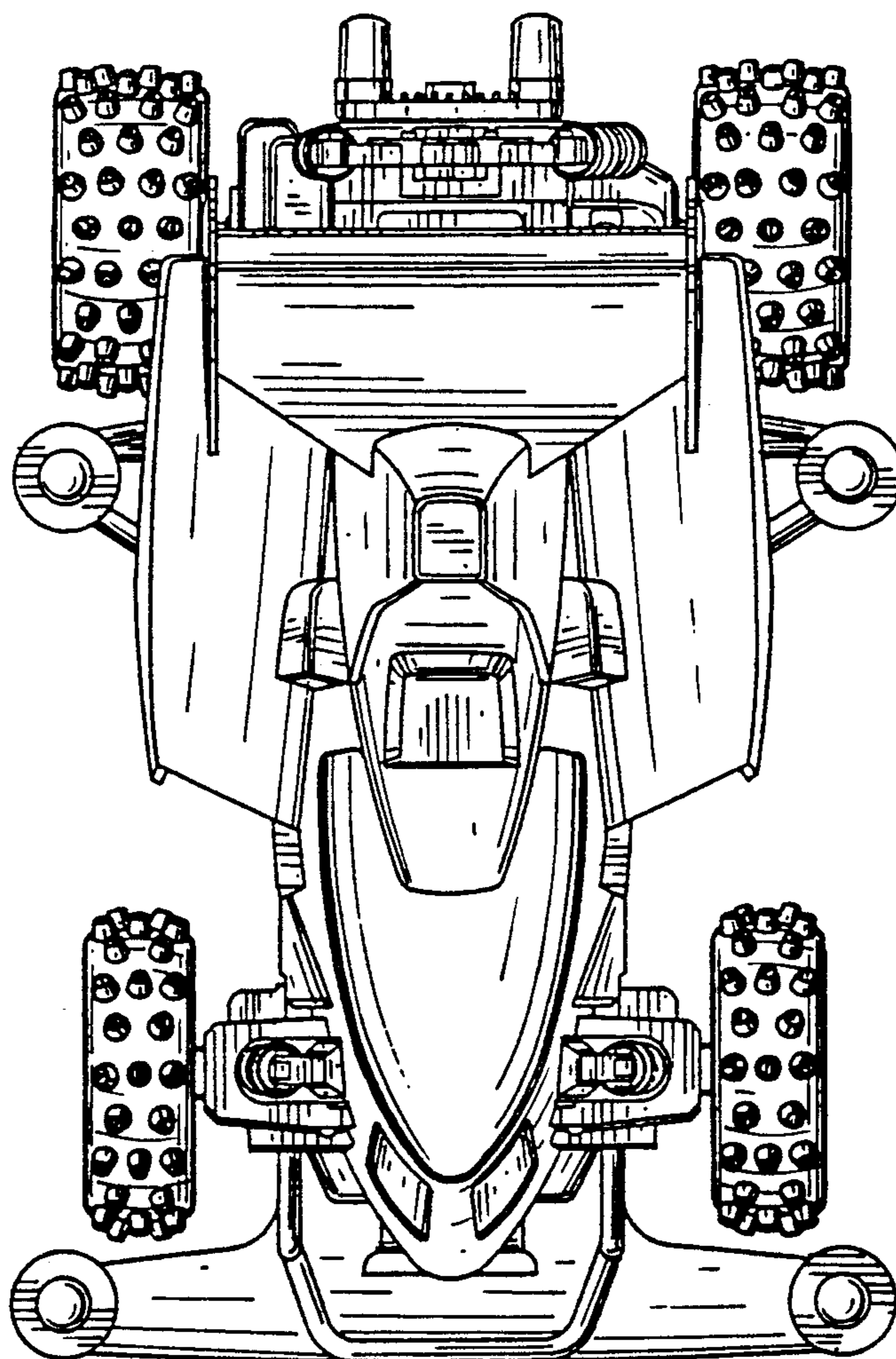

FIG. 5

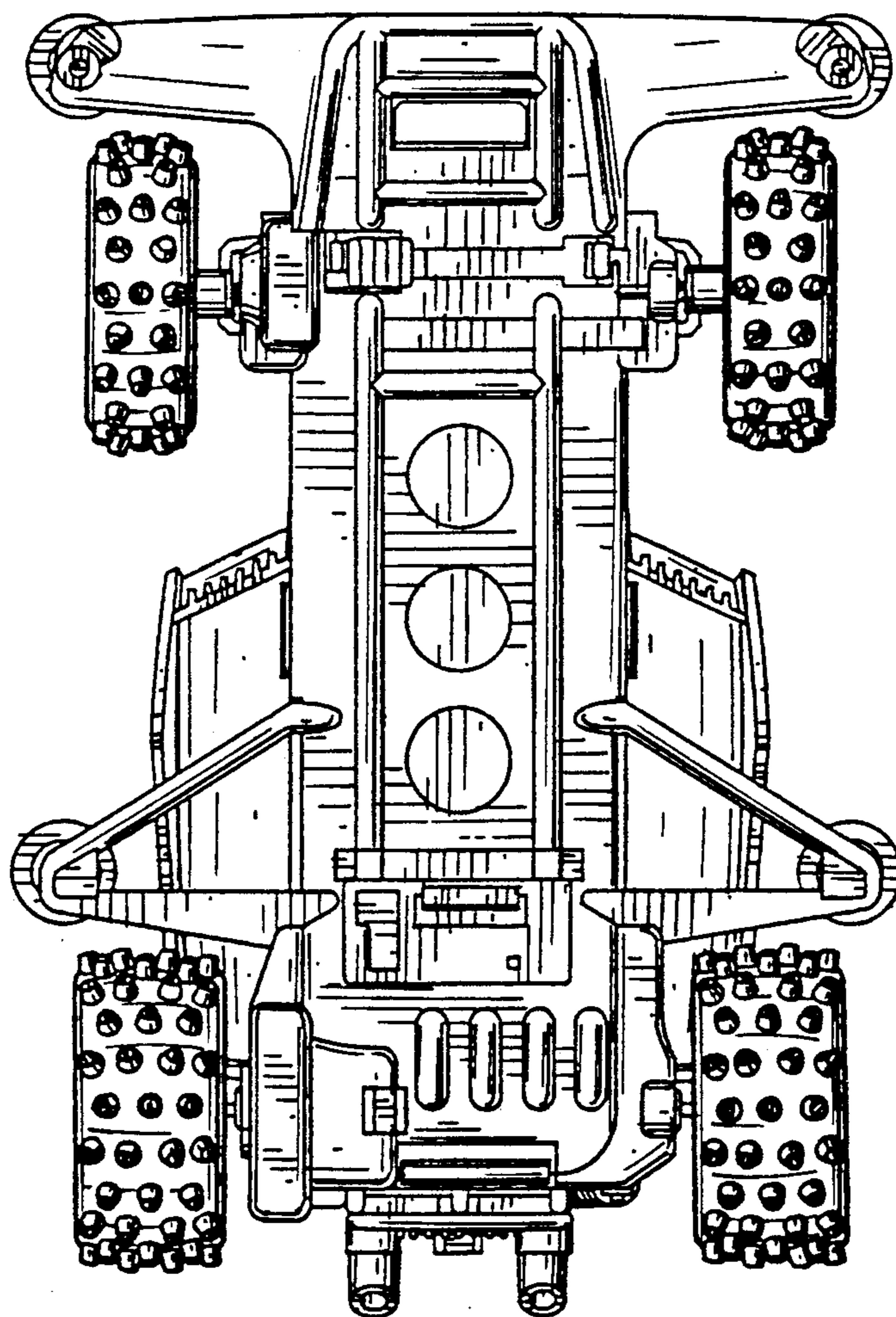

FIG. 6

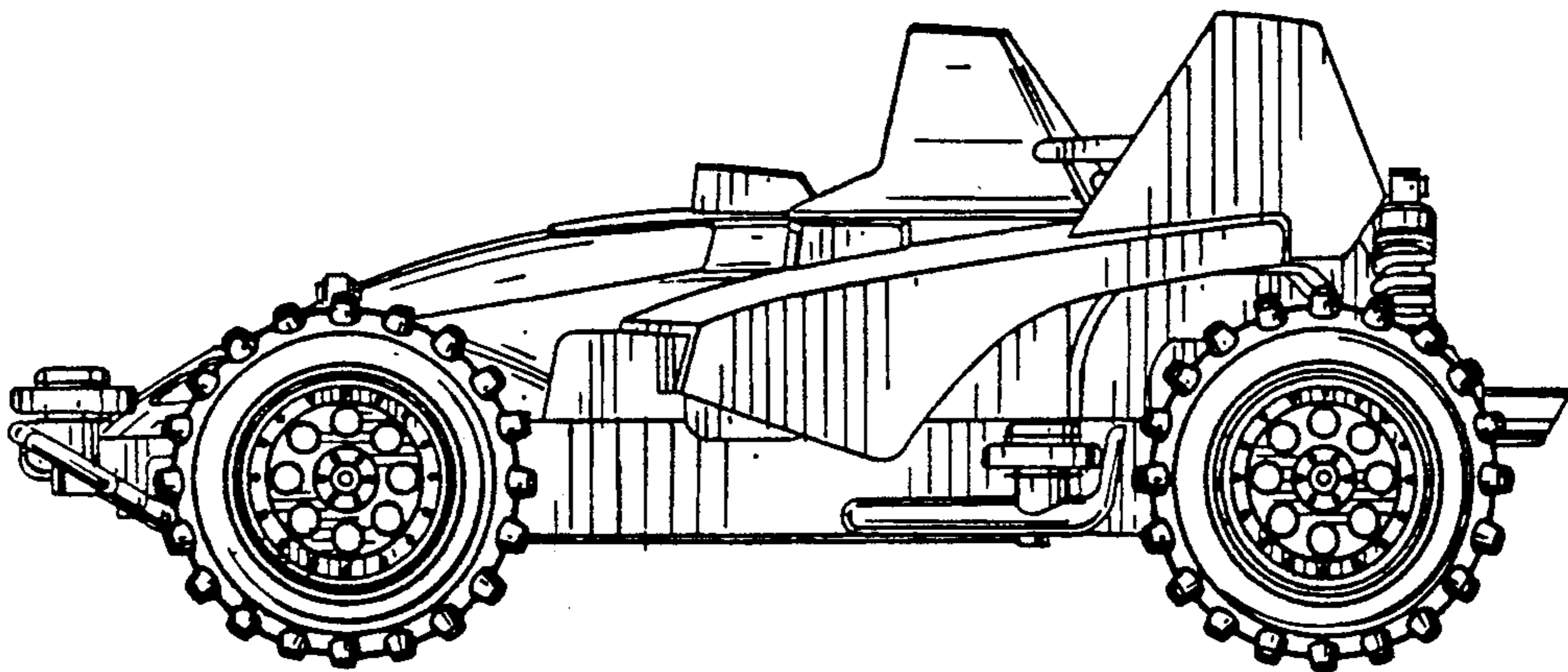

FIG. 7

