

[54] COMBINED AUTOMOBILE SPLASH GUARD AND DISPLAY UNIT

[75] Inventors: Pierre Charet; Duke Kraai, both of Miami, Fla.

[73] Assignee: Rally Manufacturing, Inc., Miami, Fla.

[*] Notice: The portion of the term of this patent subsequent to Jan. 2, 2004 has been disclaimed.

[**] Term: 14 Years

[21] Appl. No.: 151,793

[22] Filed: Feb. 3, 1988

[52] U.S. Cl. D12/185

[58] Field of Search D12/185; 280/851

[56] References Cited

U.S. PATENT DOCUMENTS

D. 281,774 12/1985 Ward D12/185
4,709,938 12/1987 Ward et al. 280/154.5 R

OTHER PUBLICATIONS

J. C. Whitney Catalog No. 468K, ©1986, p. 136, Ex-

tra-Wide Splash Guards, second box in from bottom right side of page.

J. C. Whitney Catalog, No. 468K, ©1986, p. 137, High-Style Splash Guards, top right side of page.

J. C. Whitney Catalog, No. 454D, ©1985, p. 112, Colorful Splash Guard, bottom left side of page.

Primary Examiner—James M. Gandy
Attorney, Agent, or Firm—Longacre & White

[57] CLAIM

The ornamental design for a combined automobile splash guard and display unit, as shown and described.

DESCRIPTION

FIG. 1 is a perspective view of a combined automobile splash guard and display unit showing our new design mounted on the left rear of an automobile; which is shown in broken lines of or illustrative purposes only and forms no part of the claimed design,

FIG. 2 is an enlarged front elevation view thereof; FIG. 3 is an enlarged left side elevation view thereof; FIG. 4 is an enlarged right side elevation view thereof; FIG. 5 is an enlarged rear elevation view thereof; and FIG. 6 is an enlarged bottom plan view thereof.

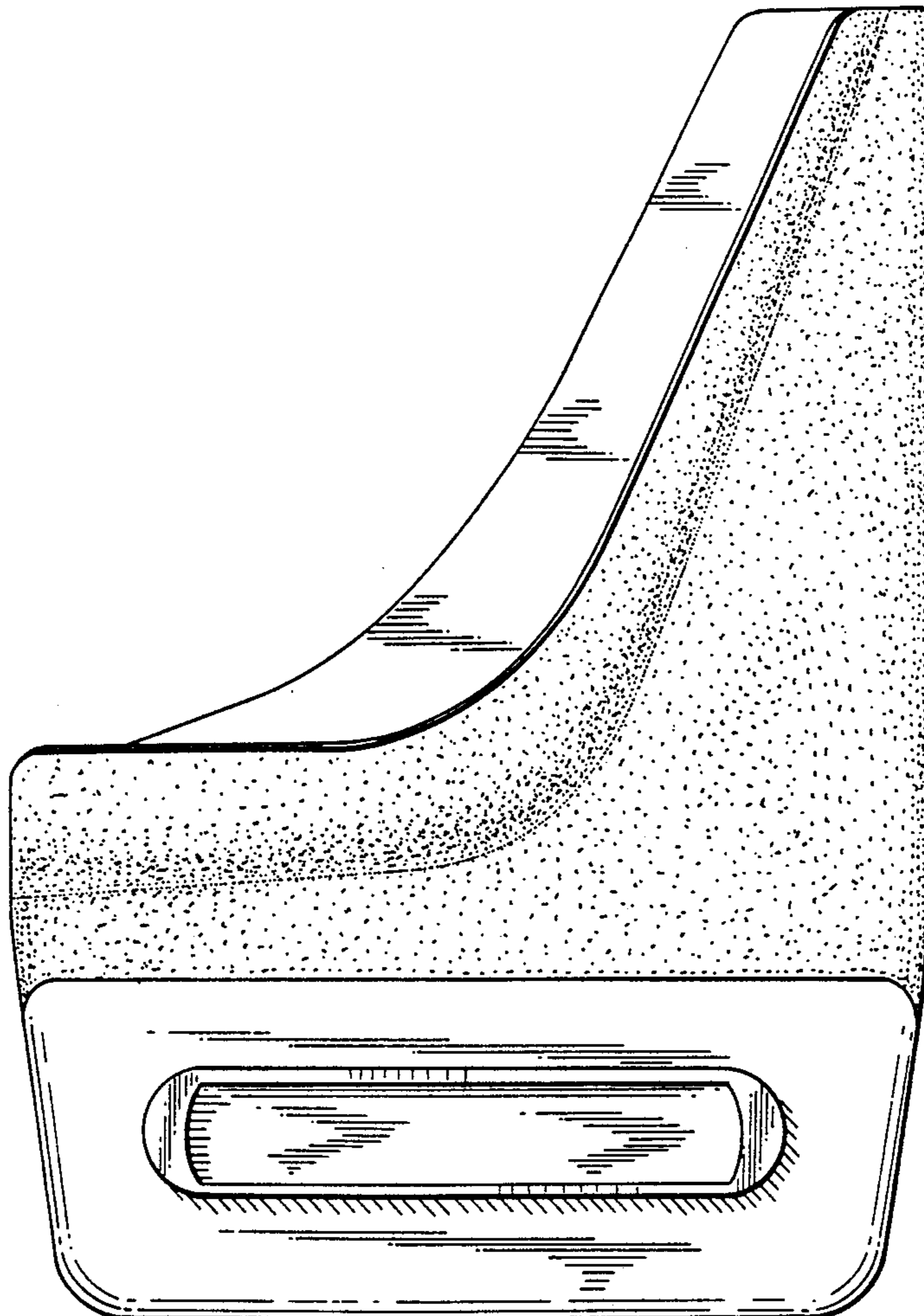

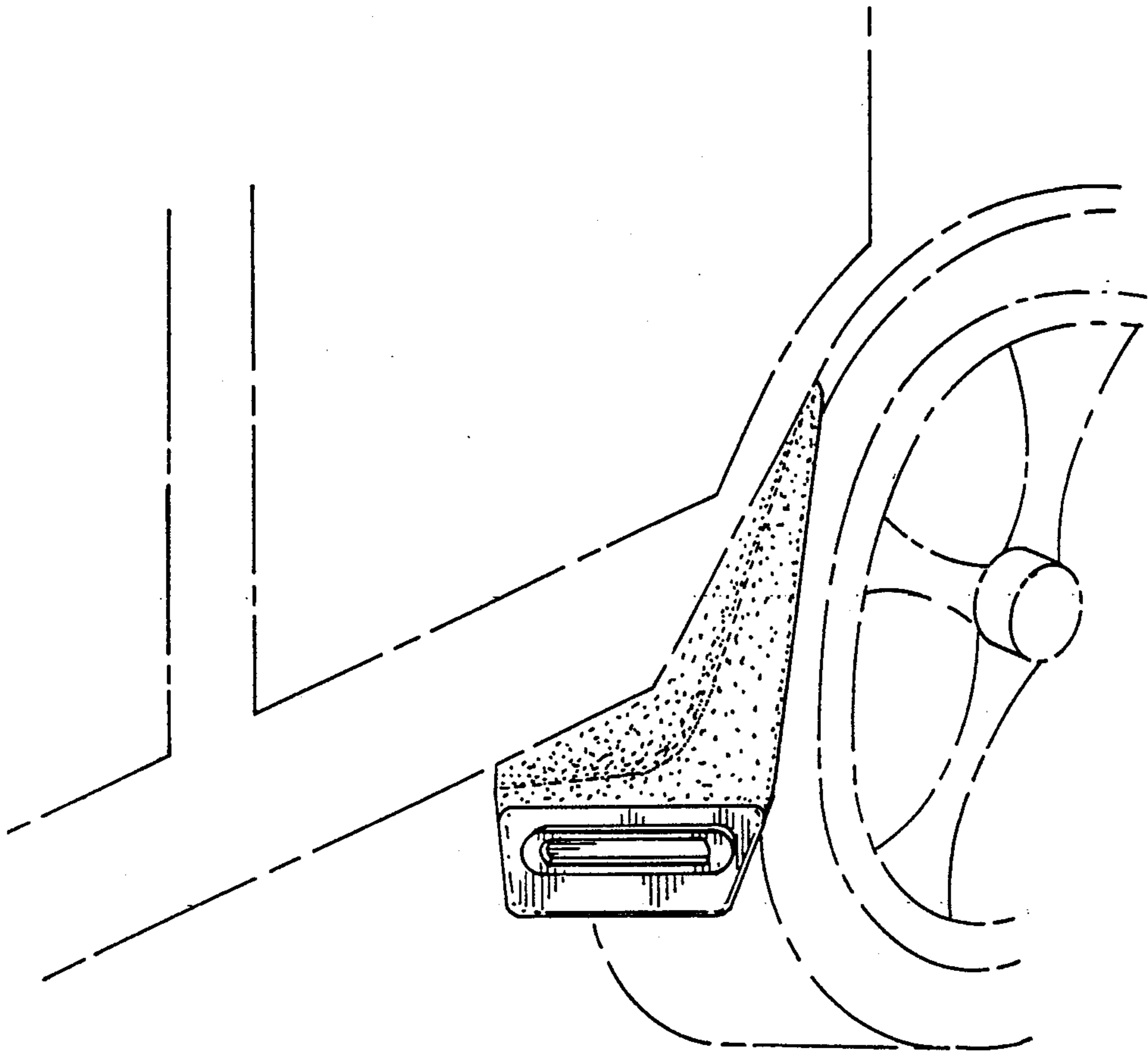

FIG. 1

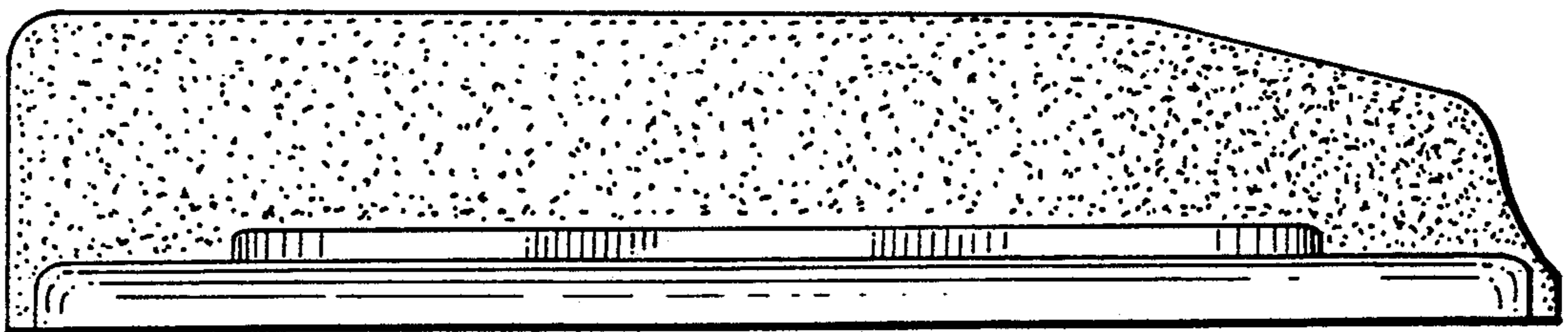

FIG. 6

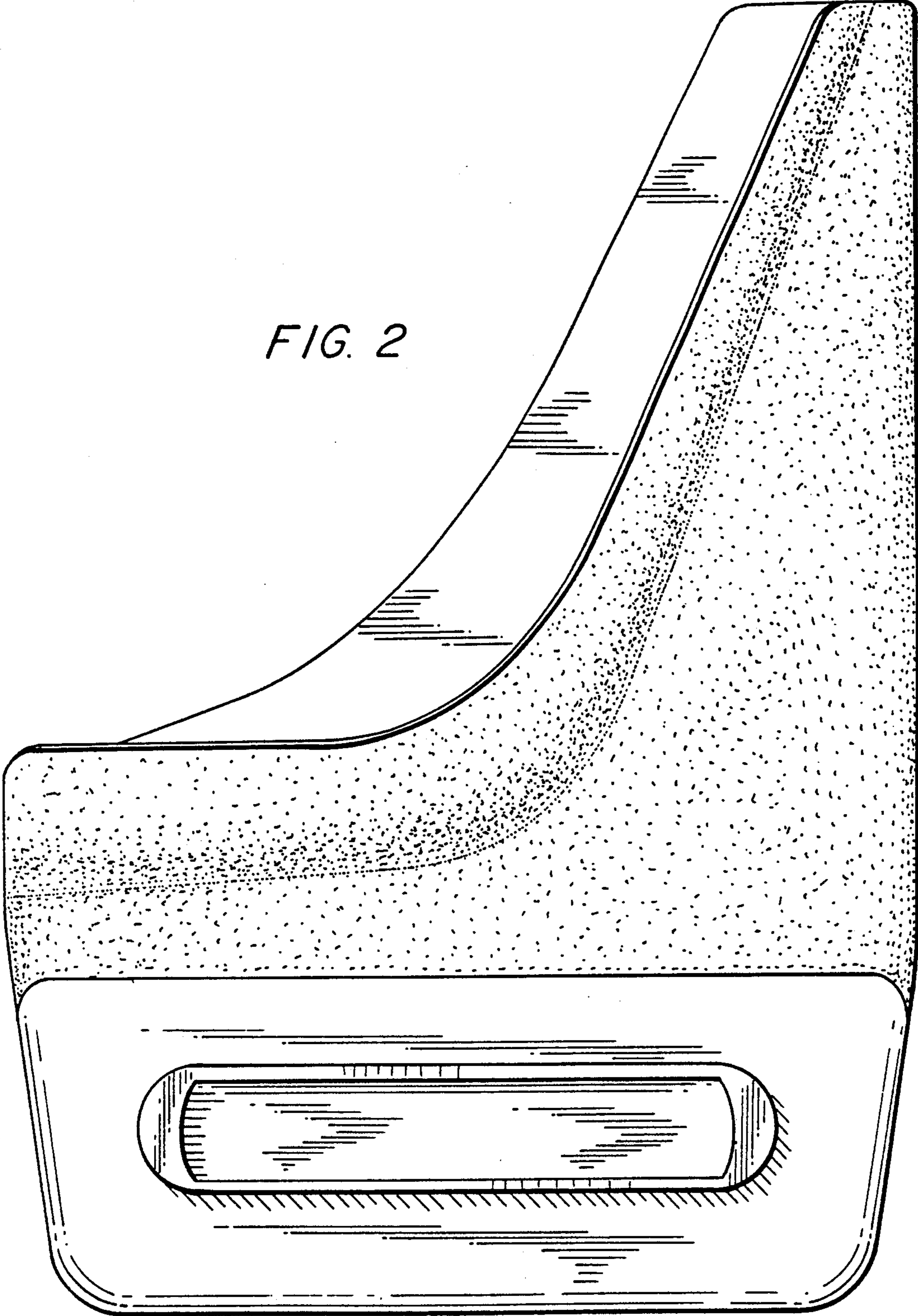

FIG. 2

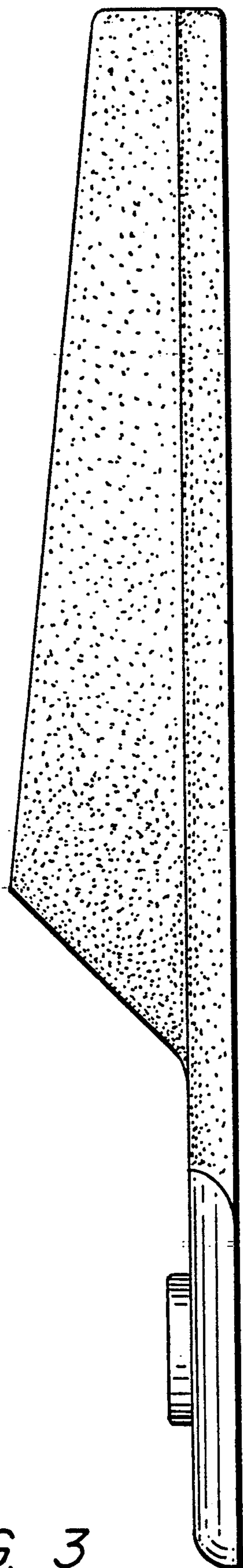

FIG. 3

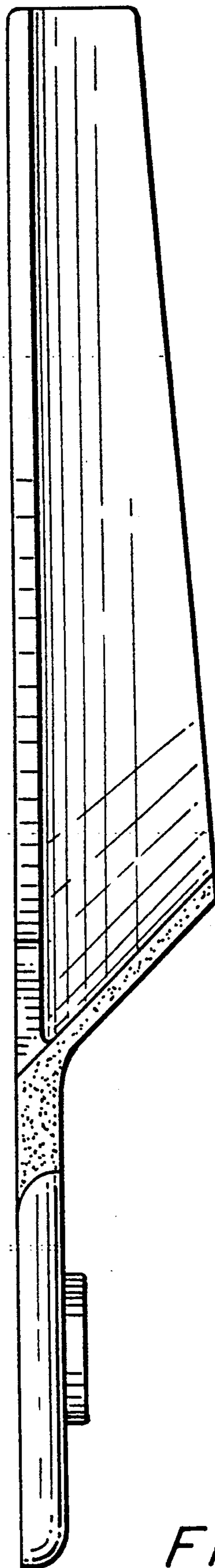

FIG. 4

