

[54] TROLLING MOTOR TILT POSITION ALARM

[76] Inventor: Samuel D. Wilson, Jr., 1523 Foxdale Dr., Murfreesboro, Tenn. 37130

[\*\*] Term: 14 Years

[21] Appl. No.: 282,298

[22] Filed: Dec. 9, 1988

[52] U.S. Cl. .... D10/106

[58] Field of Search ..... D10/106, 104, 121, 109; 340/689, 565, 566, 568, 571, 629, 630, 586, 579, 578, 551, 552, 541

[56] References Cited

U.S. PATENT DOCUMENTS

D. 291,975 9/1987 Ching-Hua ..... D10/106  
4,278,854 7/1981 Krause ..... 340/689

4,841,285 6/1989 Laut ..... 340/689

Primary Examiner—Wallace R. Burke  
Assistant Examiner—Marcus Jackson  
Attorney, Agent, or Firm—Jerry T. Kearns

[57] CLAIM

The ornamental design for a trolling motor tilt position alarm, as shown and described.

DESCRIPTION

FIG. 1 is a front elevational view of a trolling motor tilt position alarm showing my new design, with the cords broken away in the center to indicate indeterminate length.

FIG. 2 is a rear elevational view thereof;

FIG. 3 is a left side elevational view thereof;

FIG. 4 is a right side elevational view thereof;

FIG. 5 is a top plan view thereof; and,

FIG. 6 is a bottom plan view thereof.

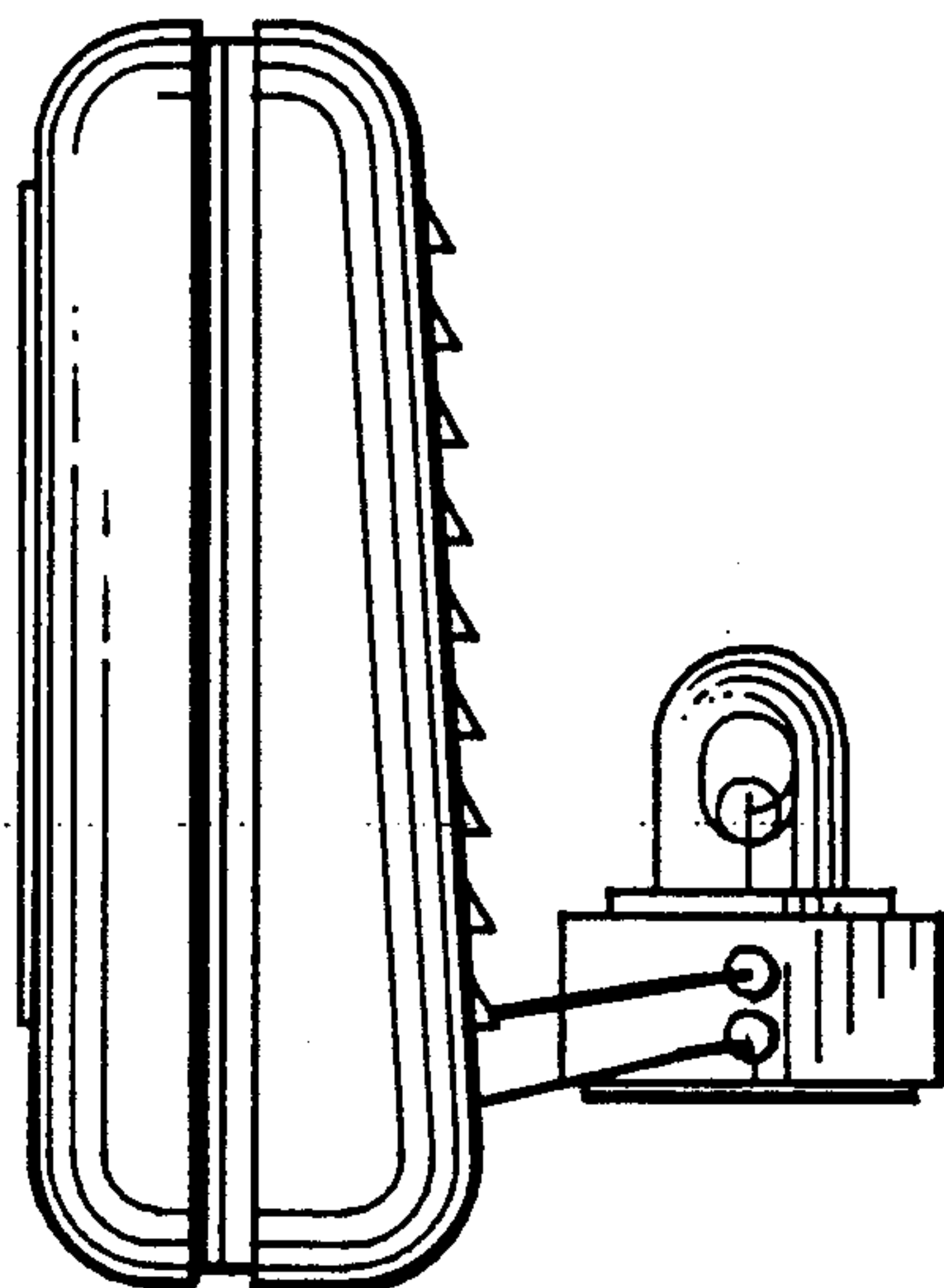
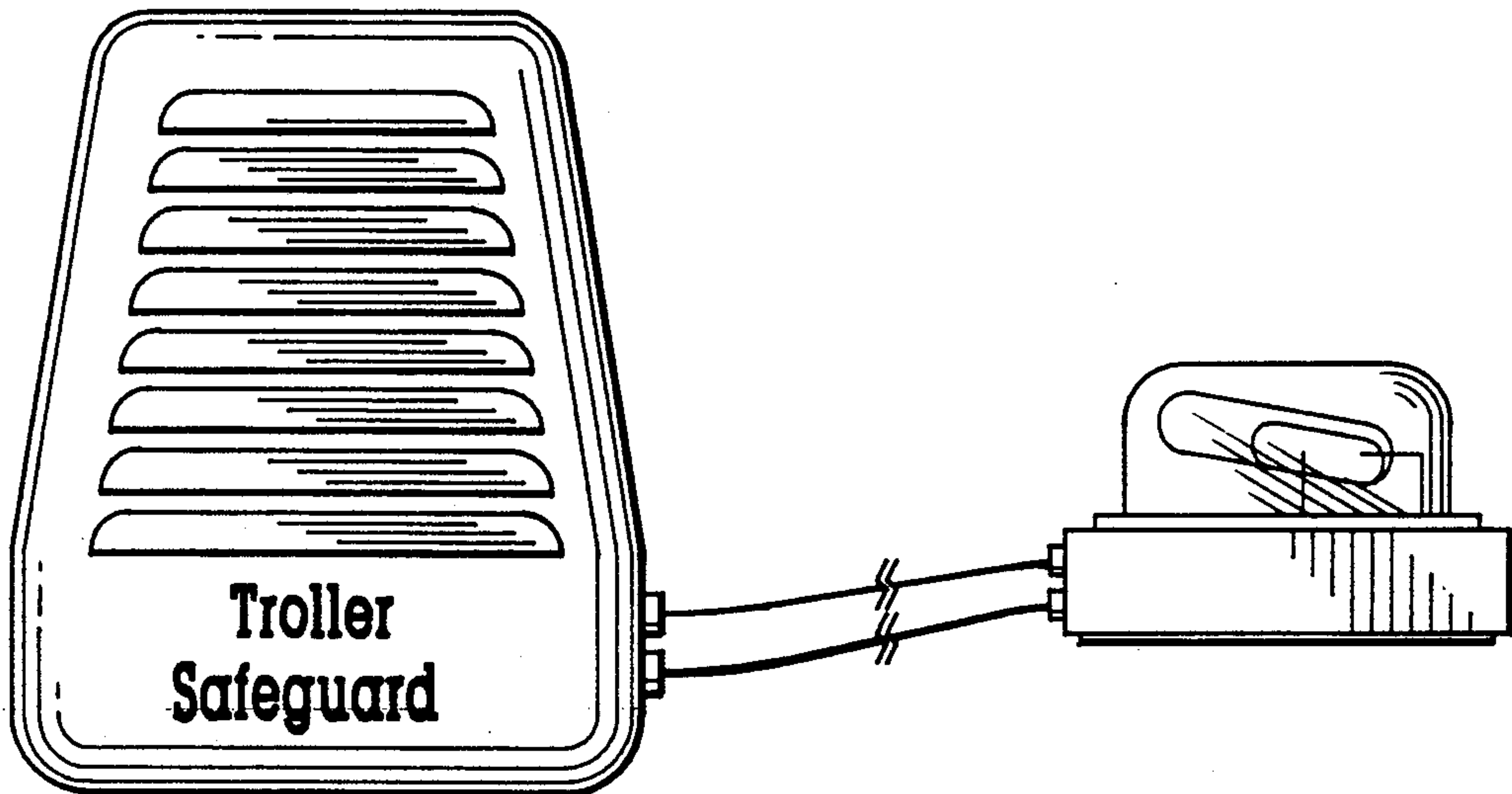

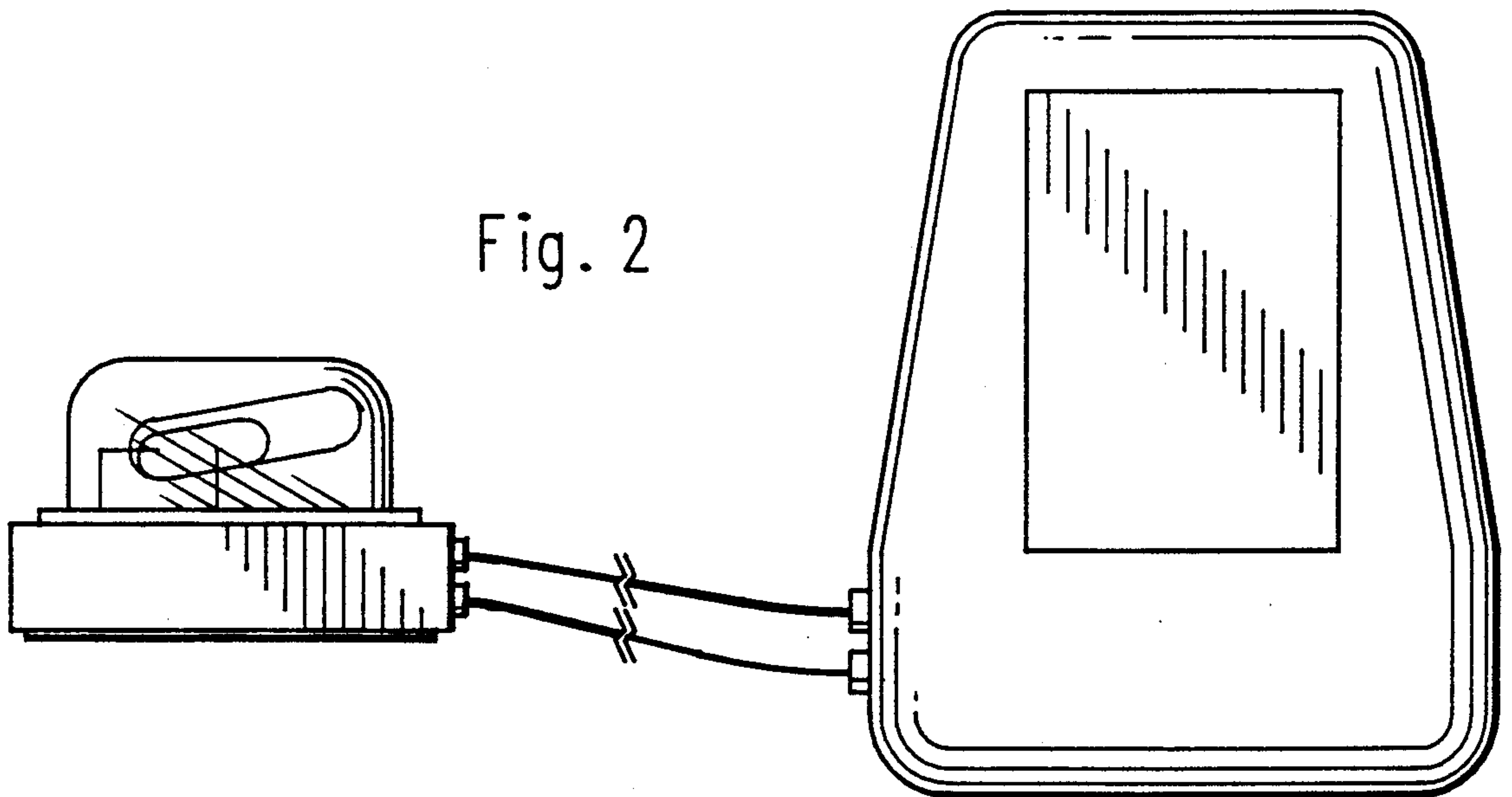
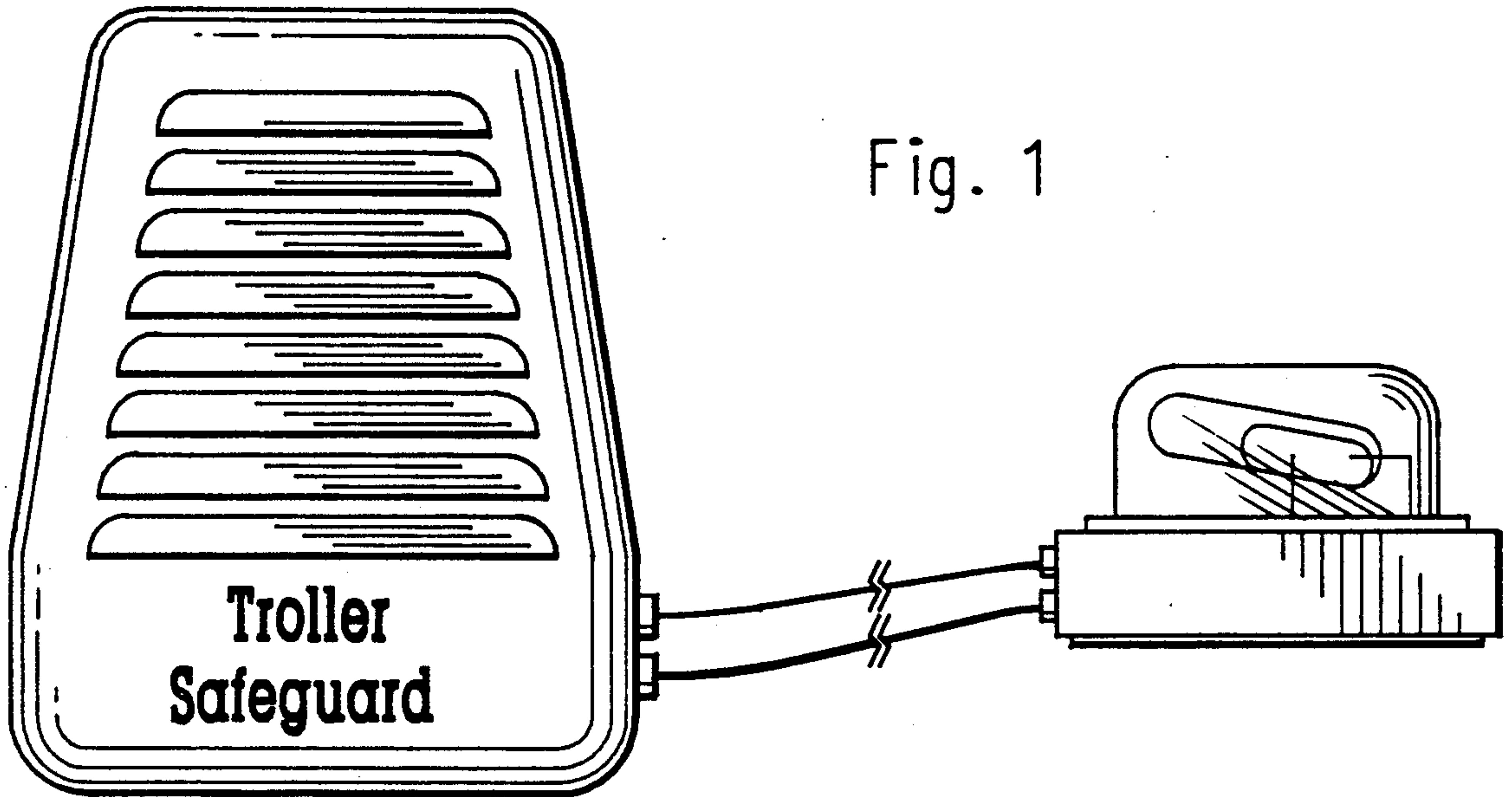

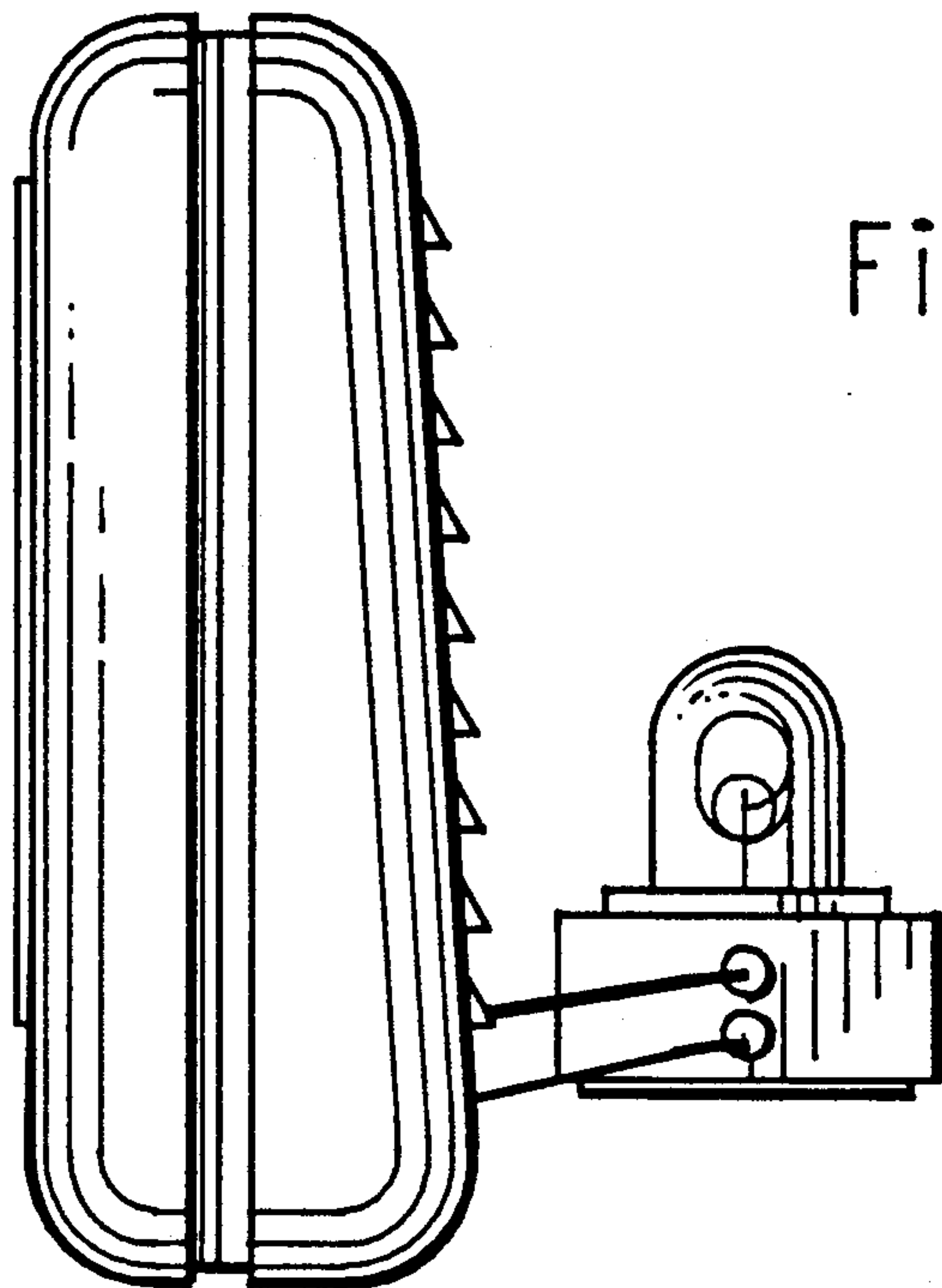
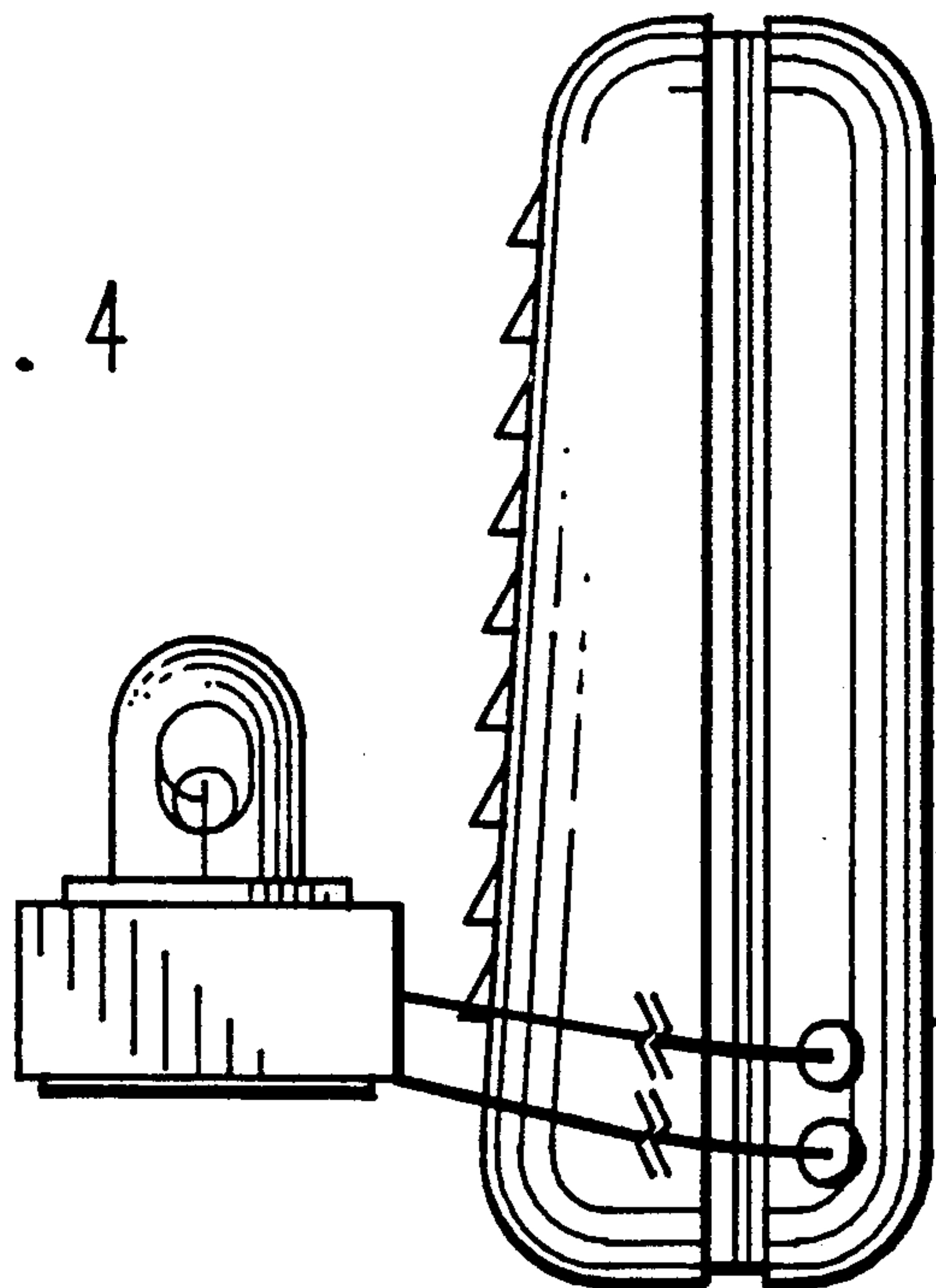

Fig. 3

Fig. 4



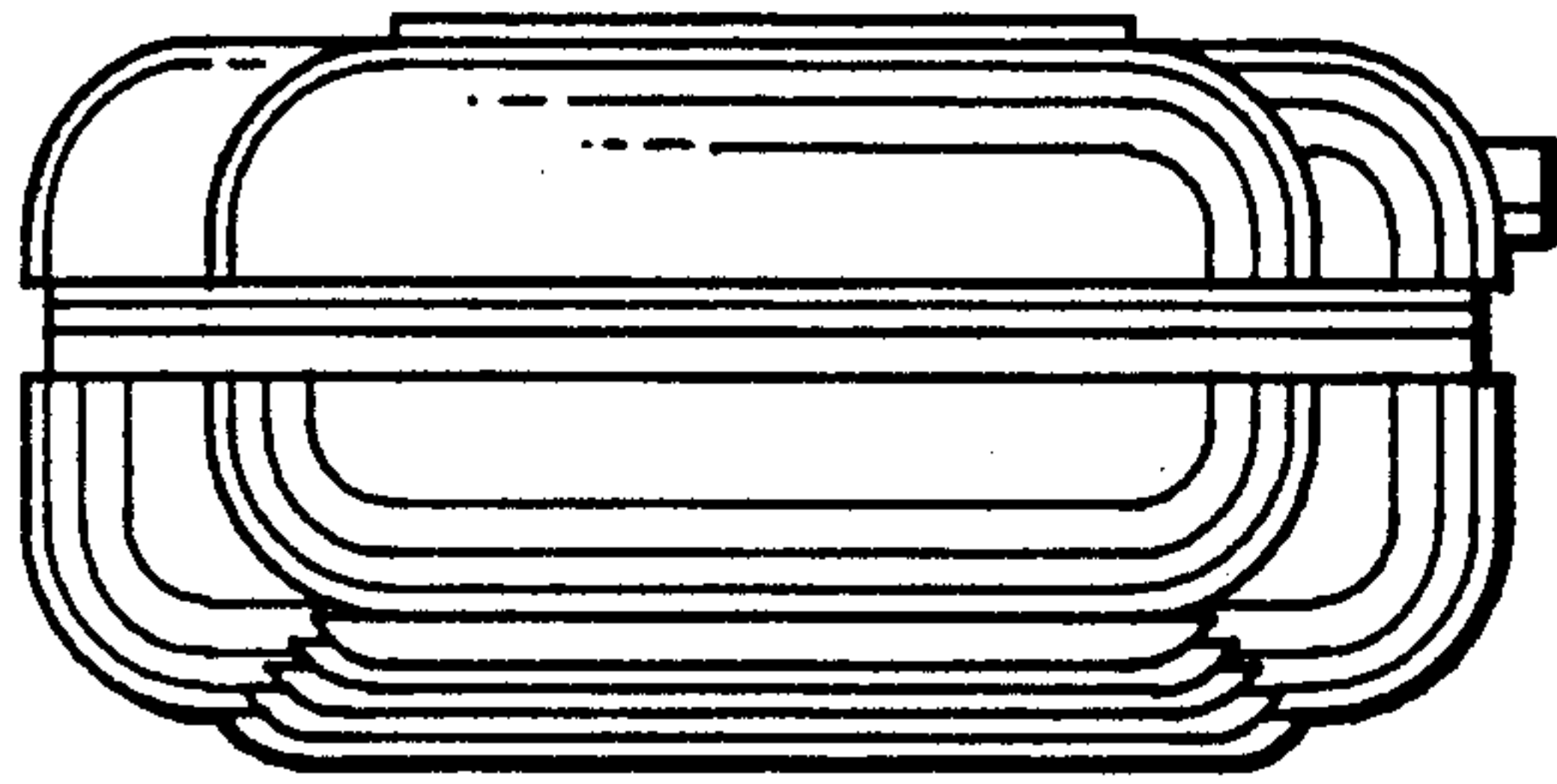

Fig. 5

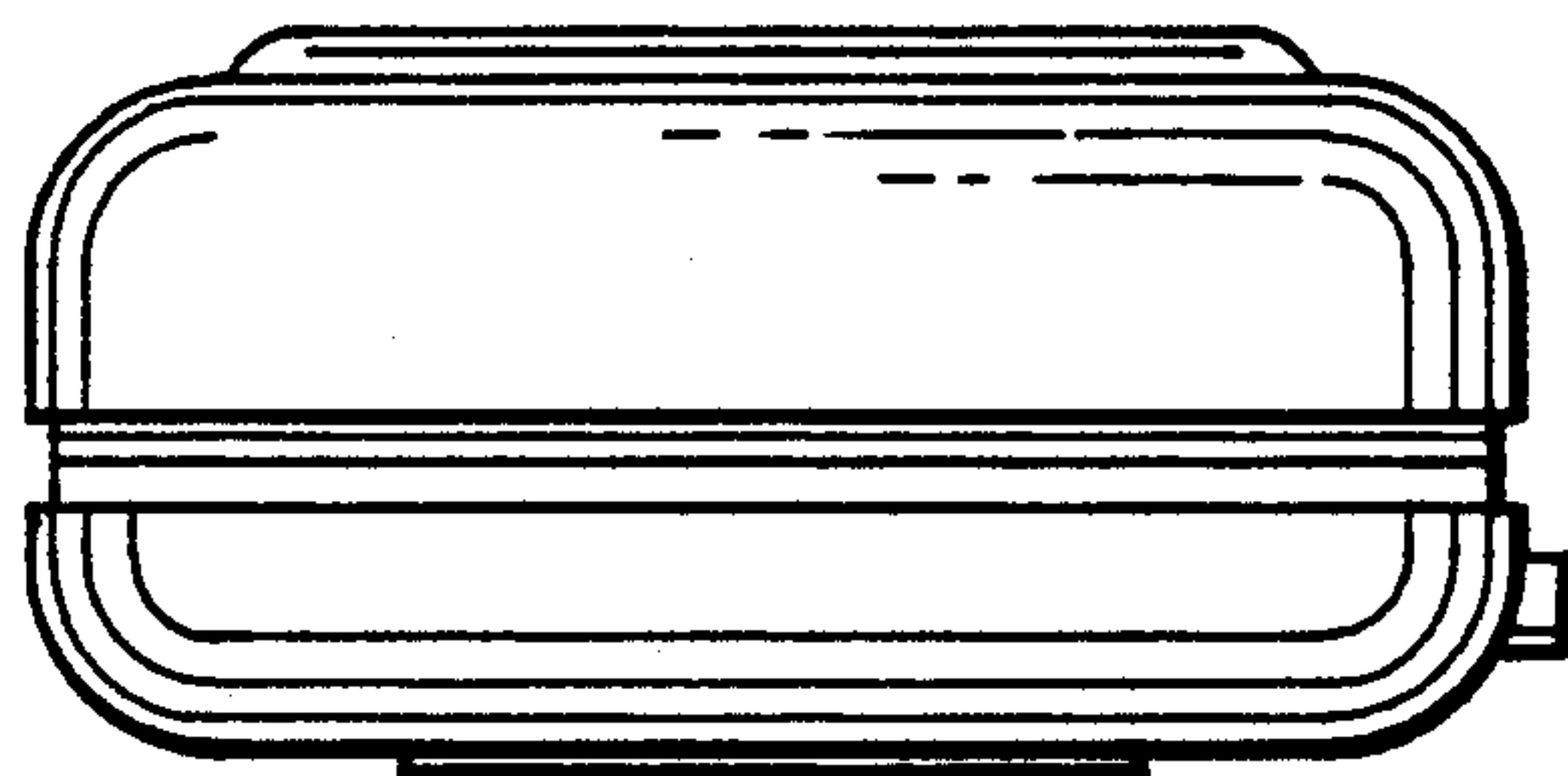
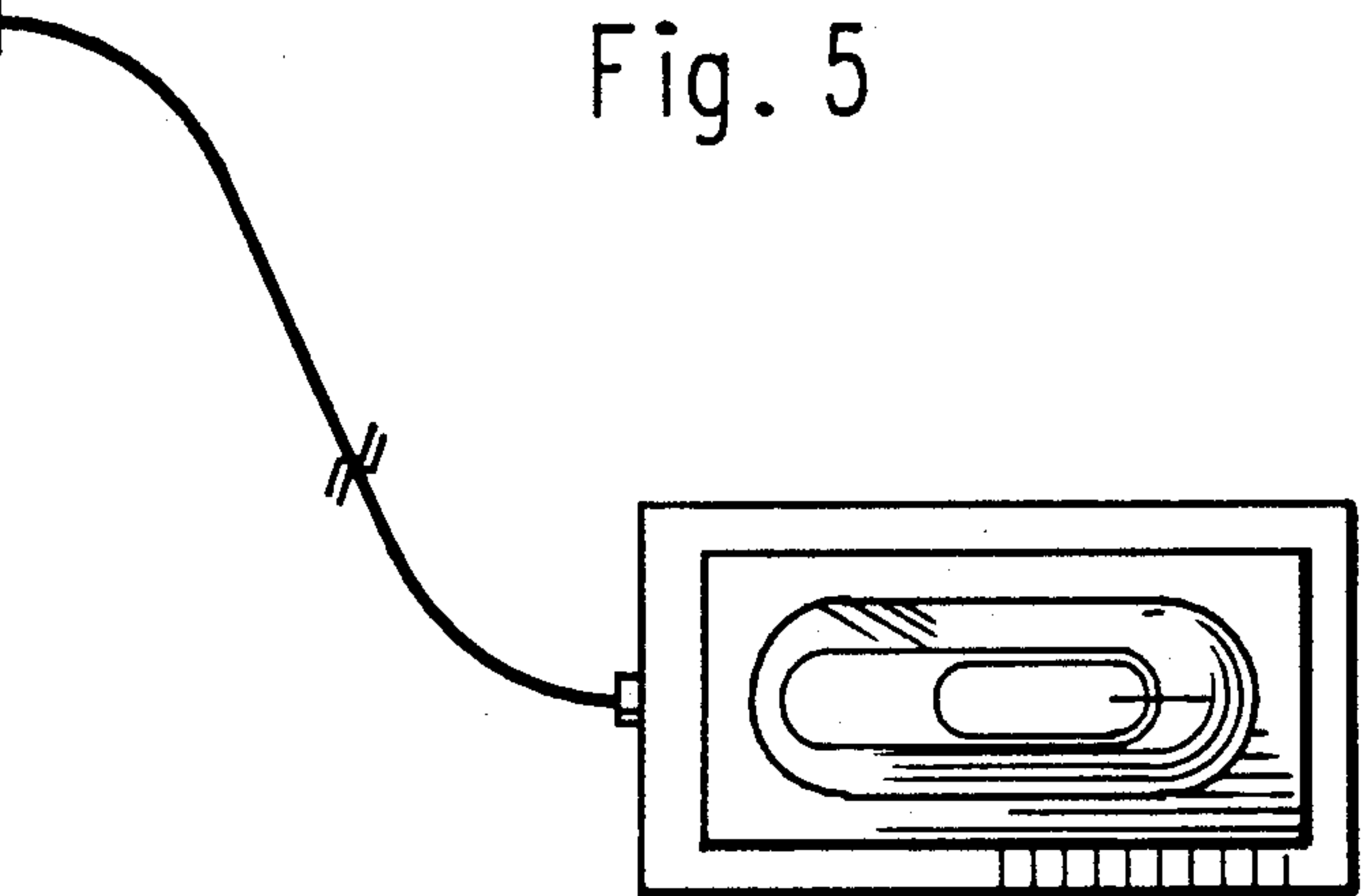

Fig. 6

