

[54] **WHEEL**

[75] **Inventor: Adolf Koch, Waiblingen-Neustadt, Fed. Rep. of Germany**

[73] **Assignee: Sport-Service-Lorinser Sportliche Autoausrüstung GmbH, Waiblingen, Fed. Rep. of Germany**

[**] **Term: 14 Years**

[21] **Appl. No.: 808,430**

[22] **Filed: Dec. 12, 1985**

[30] **Foreign Application Priority Data**

Jul. 11, 1985 [DE] Fed. Rep. of Germany 1036

[52] **U.S. Cl. D12/211**

[58] **Field of Search D12/209, 211; 301/63 R, 301/64 R, 64 SD, 65**

[56] **References Cited**

U.S. PATENT DOCUMENTS

D. 204,669 5/1966 Goodwin D12/209

D. 207,001 2/1967 Fenton D12/211

D. 216,507 1/1970 Whitney D12/211
D. 223,534 5/1972 Reid D12/209
D. 236,459 8/1975 Covert D12/211

OTHER PUBLICATIONS

Road & Track, 5/84, p. 41, Jaguar XJ-40 Wheel, bottom center of page.

Road & Track, 1/84, p. 71, Nissan 300 ZX Wheel, center left side of page.

Primary Examiner—James M. Gandy

Attorney, Agent, or Firm—Michael J. Striker

[57] **CLAIM**

The ornamental design for a wheel, as shown.

DESCRIPTION

FIG. 1 is a perspective front view of a wheel embodying my new design;

FIG. 2 is a front elevation view thereof.

FIG. 3 is a sectional view thereof taken along line 3—3 in FIG. 2;

FIG. 4 is a side elevation view thereof;

FIG. 5 is a rear elevation view thereof.

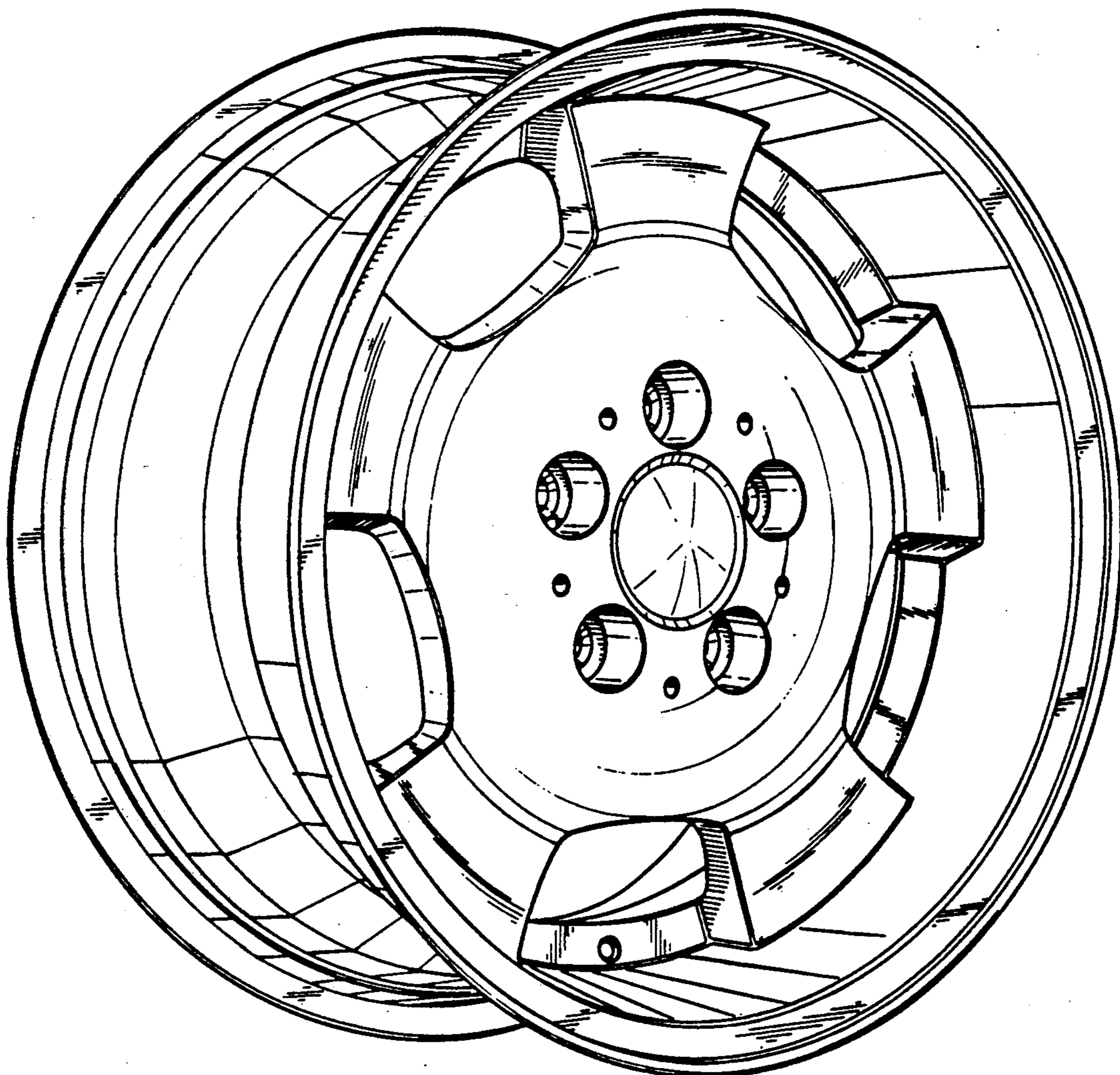

Fig. 1

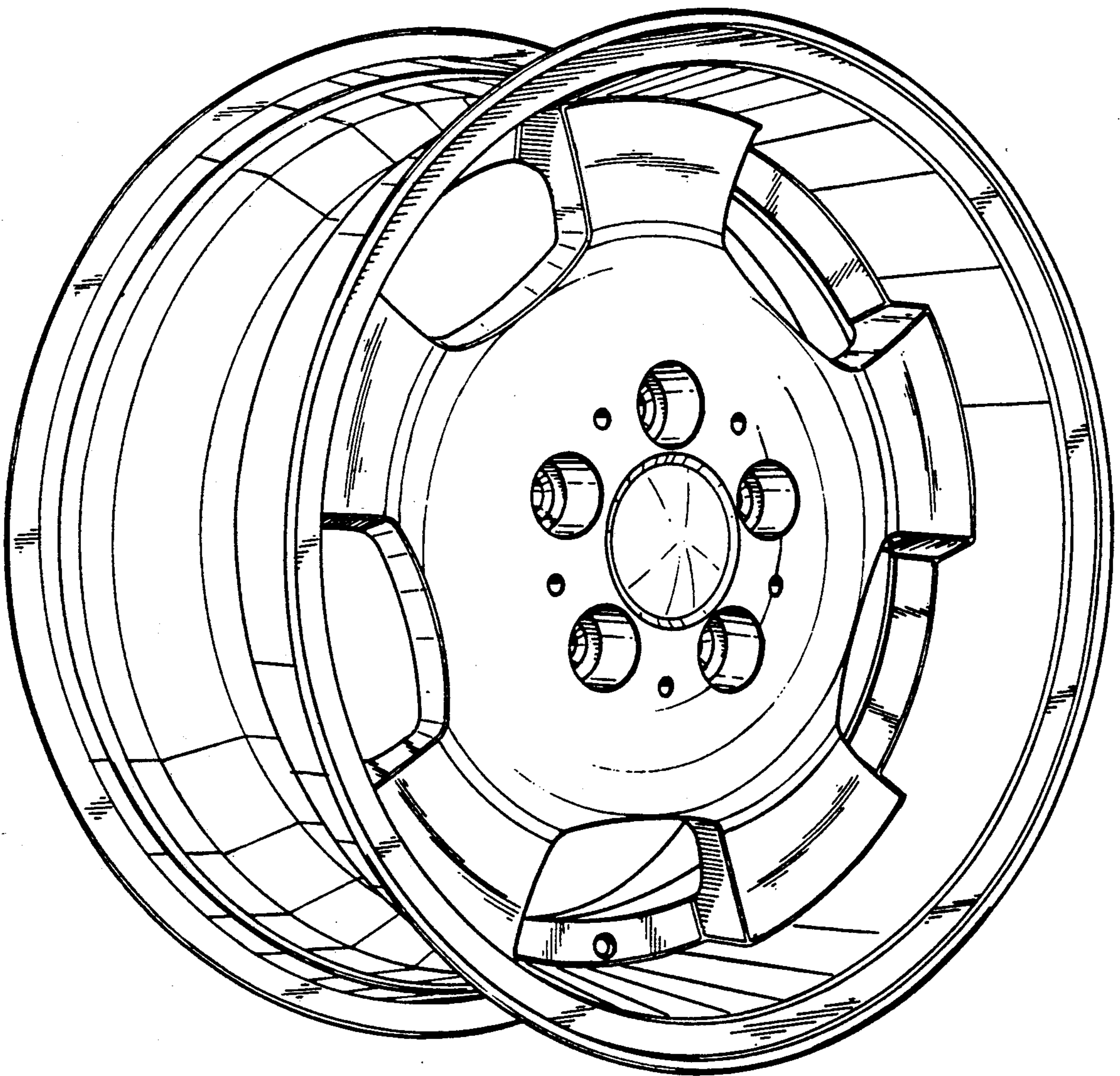

Fig. 3

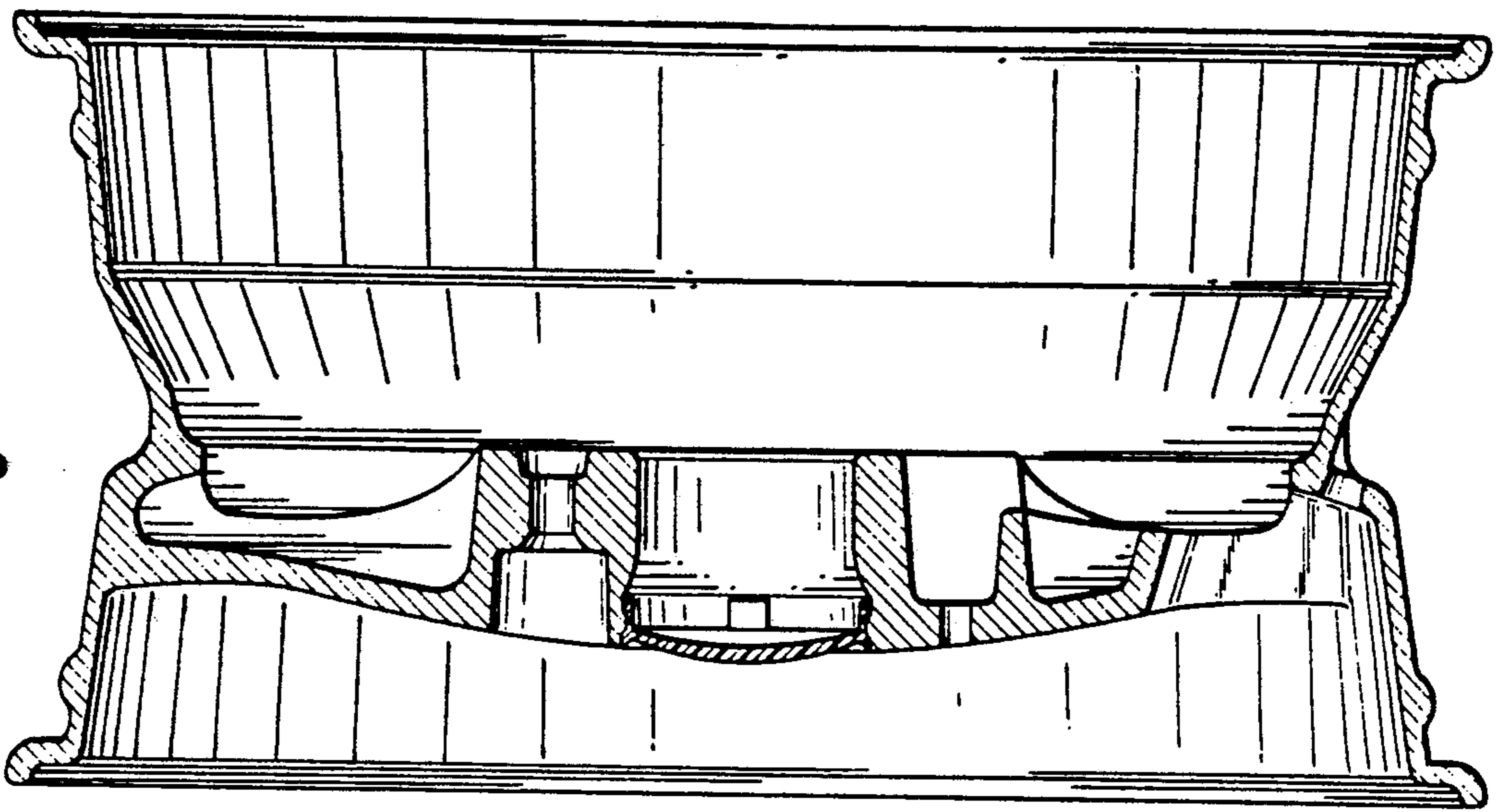

Fig. 2

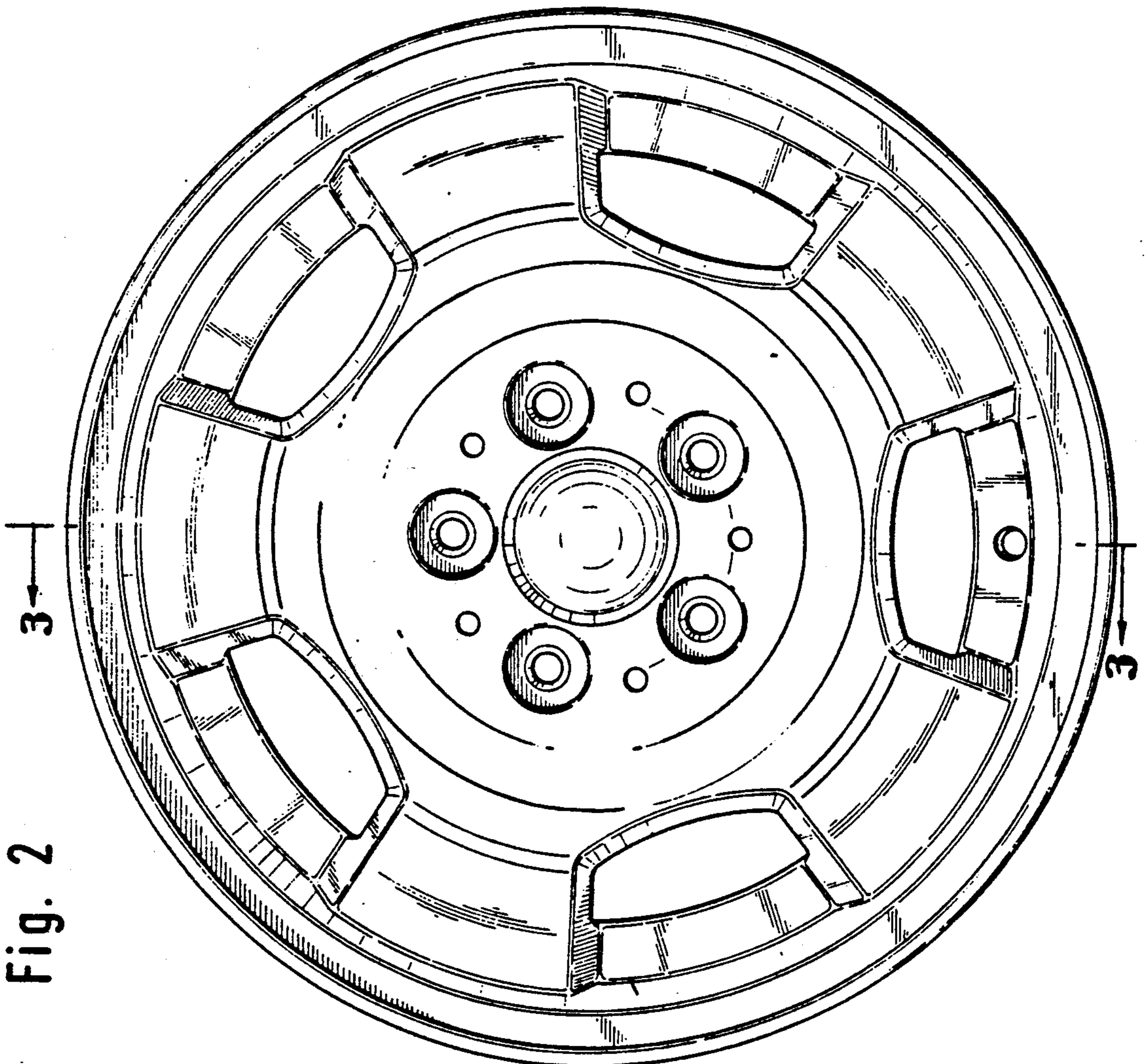

Fig. 5

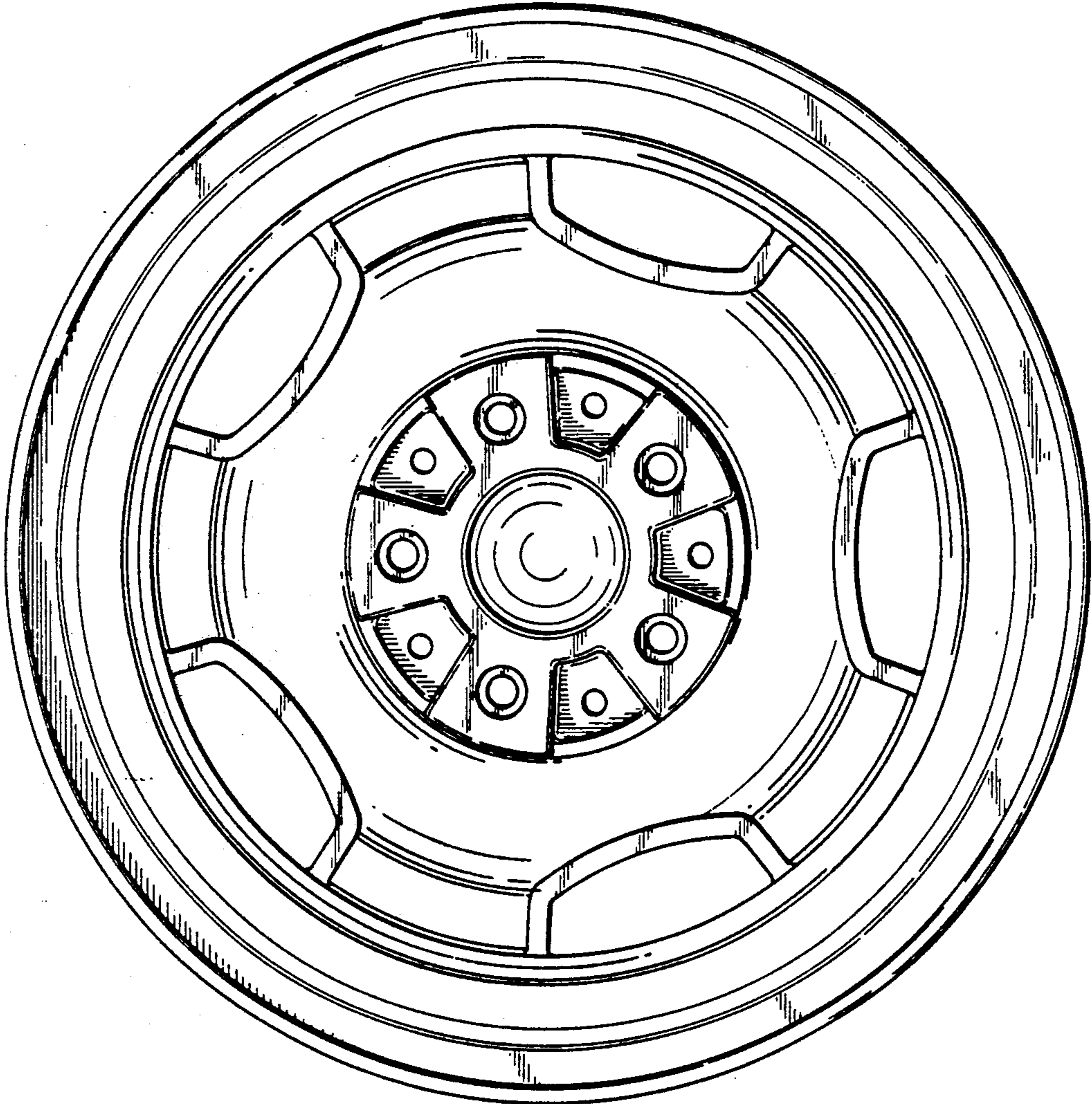

Fig. 4

