

[54] **ADJUSTABLE LUGGAGE CARRIER CROSS RAIL WITH LOCKING LEVER**

Attorney, Agent, or Firm—Edgar A. Zarins; Malcolm L. Sutherland

[75] **Inventors: William A. Razor, Goodells; Craig Stapleton, Port Huron, both of Mich.**

[57] **CLAIM**

The ornamental design for adjustable luggage carrier cross rail with locking lever, as shown and described.

[73] **Assignee: Huron/St. Clair Incorporated, Port Huron, Mich.**

DESCRIPTION

[**] **Term: 14 Years**

FIG. 1 is a perspective view of an adjustable luggage carrier cross rail with locking lever showing our new design, it being understood that the broken lines are for illustrative purposes only and form no part of the claimed design;

[21] **Appl. No.: 192,403**

FIG. 2 is an enlarged fragmentary top plan view of one end thereof;

[22] **Filed: May 3, 1988**

[52] **U.S. Cl. D12/157**

FIG. 3 is an enlarged fragmentary cross-sectional view taken along the lines 3—3 in FIG. 2;

[58] **Field of Search D12/157; 224/309, 317, 224/321, 322, 324, 325, 326, 327**

FIG. 4 is a greatly enlarged fragmentary cross-sectional view taken along the lines 4—4 in FIG. 2;

[56] **References Cited**

U.S. PATENT DOCUMENTS

4,500,020 2/1985 Rason 224/321

FIG. 5 is a greatly enlarged end elevation view thereof, the opposite end being a mirror image of that shown; and

Primary Examiner—James M. Gandy
Assistant Examiner—Melody Brown

FIG. 6 is a greatly enlarged fragmentary bottom plan view thereof to a scale slightly less than that of FIGS. 4 and 5.

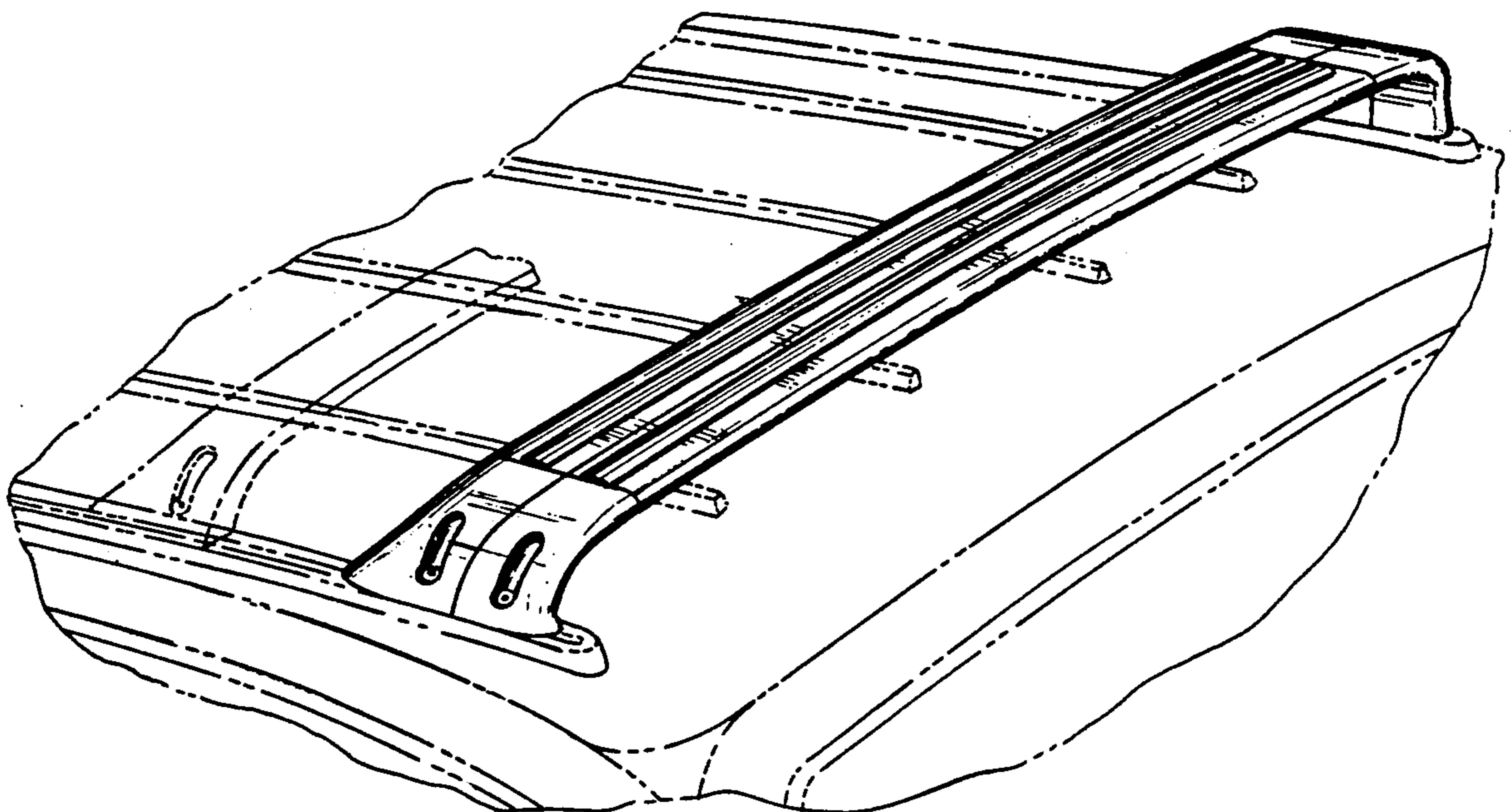

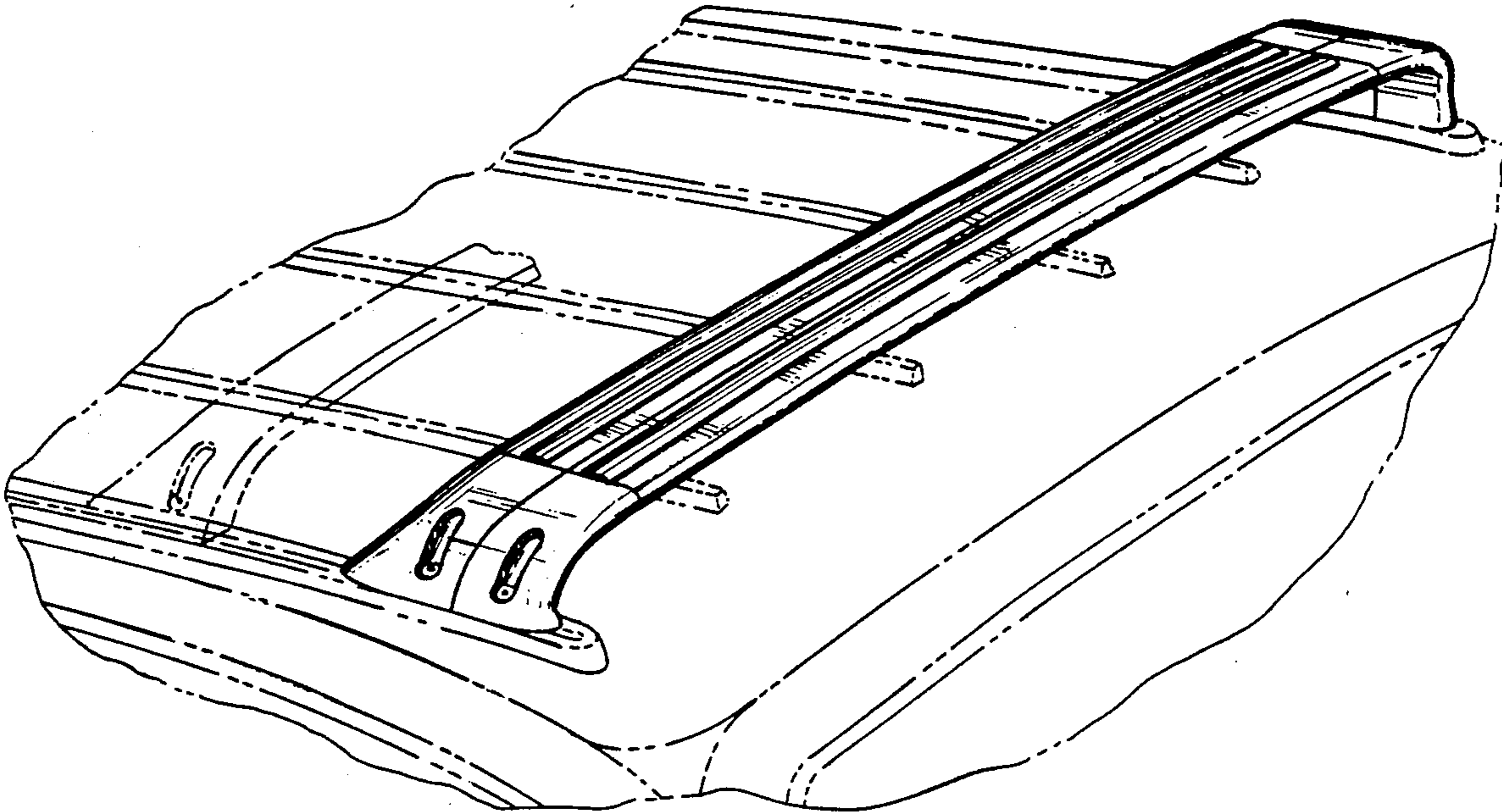

Fig-1

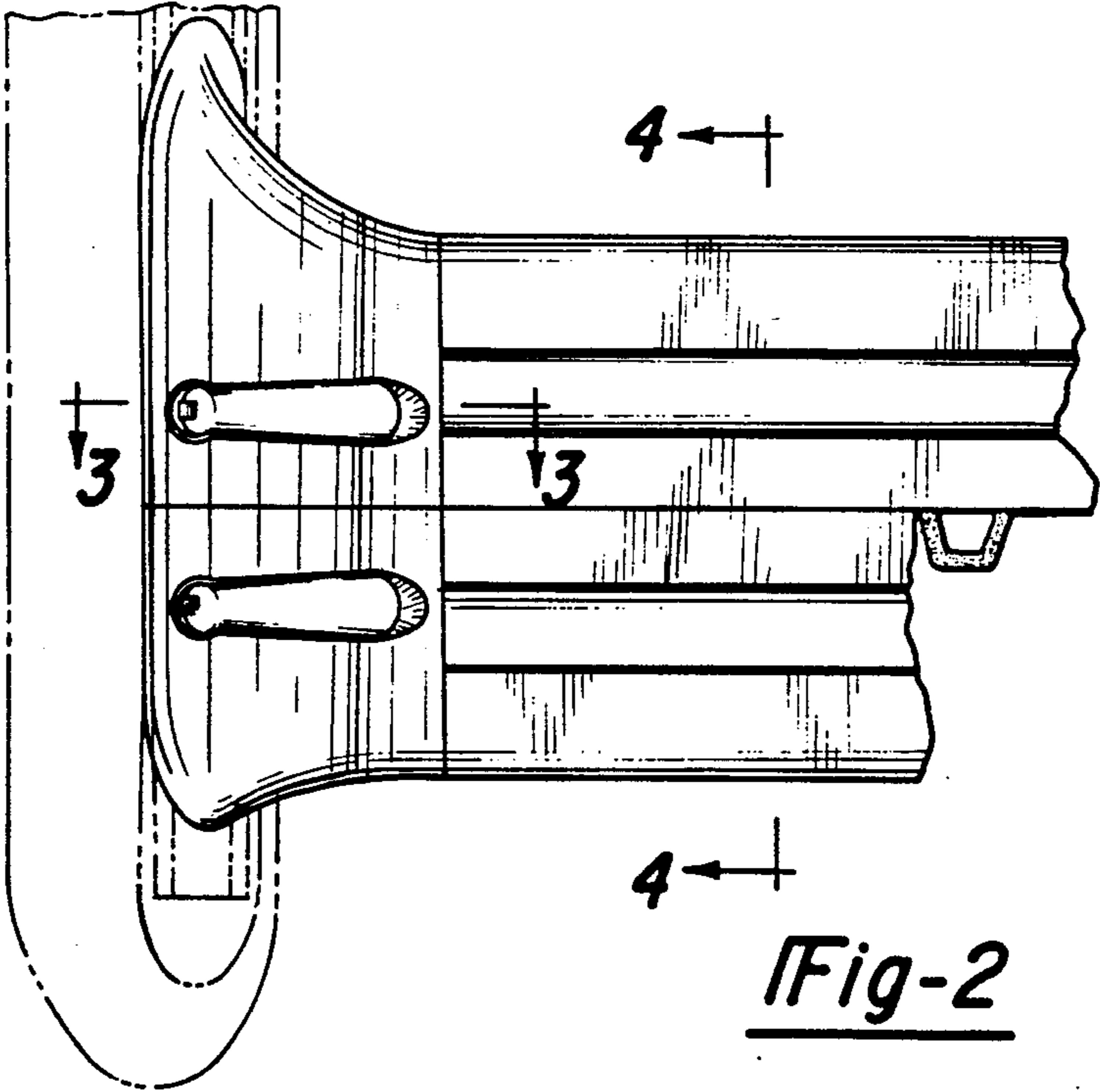

Fig-2

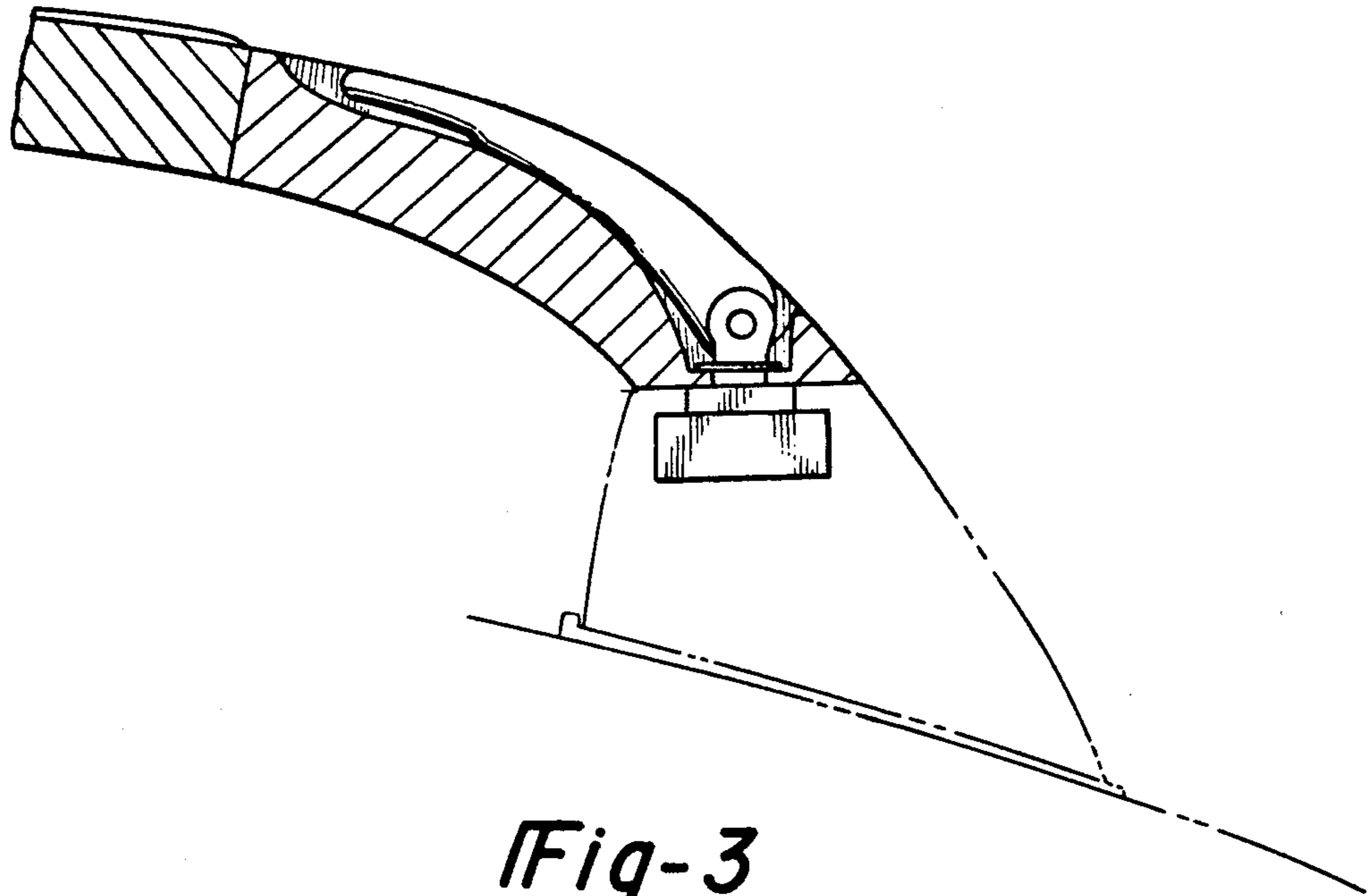

Fig-3

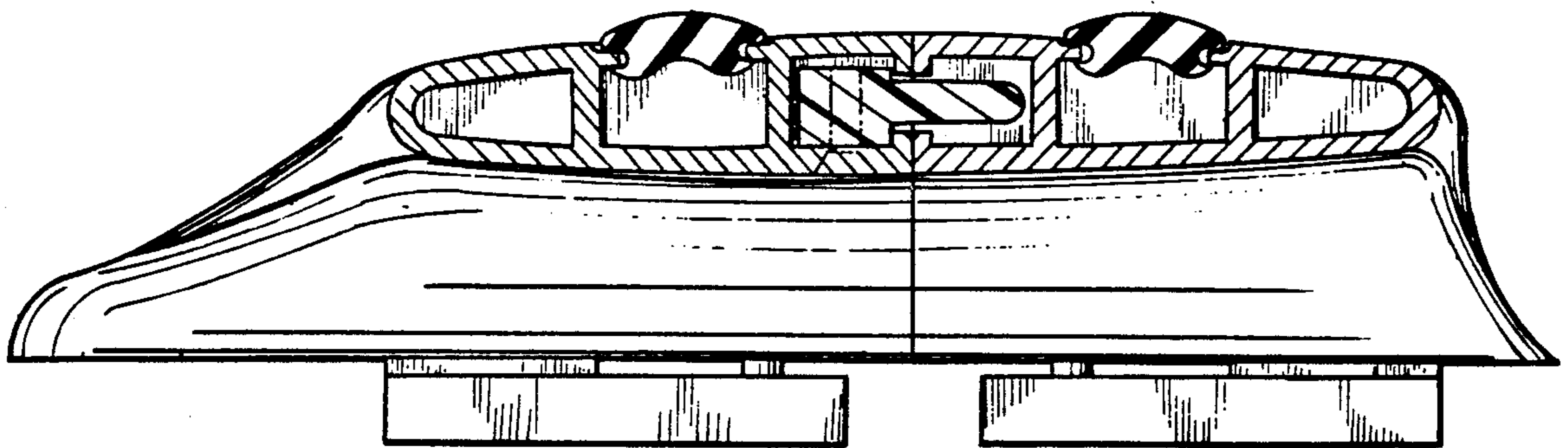

Fig-4

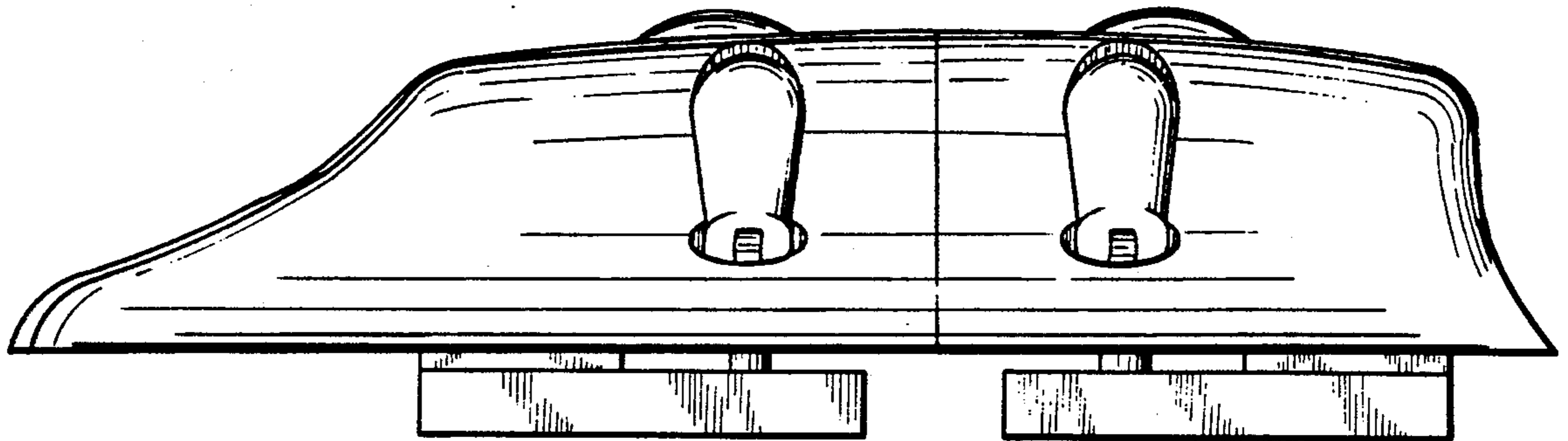

Fig-5

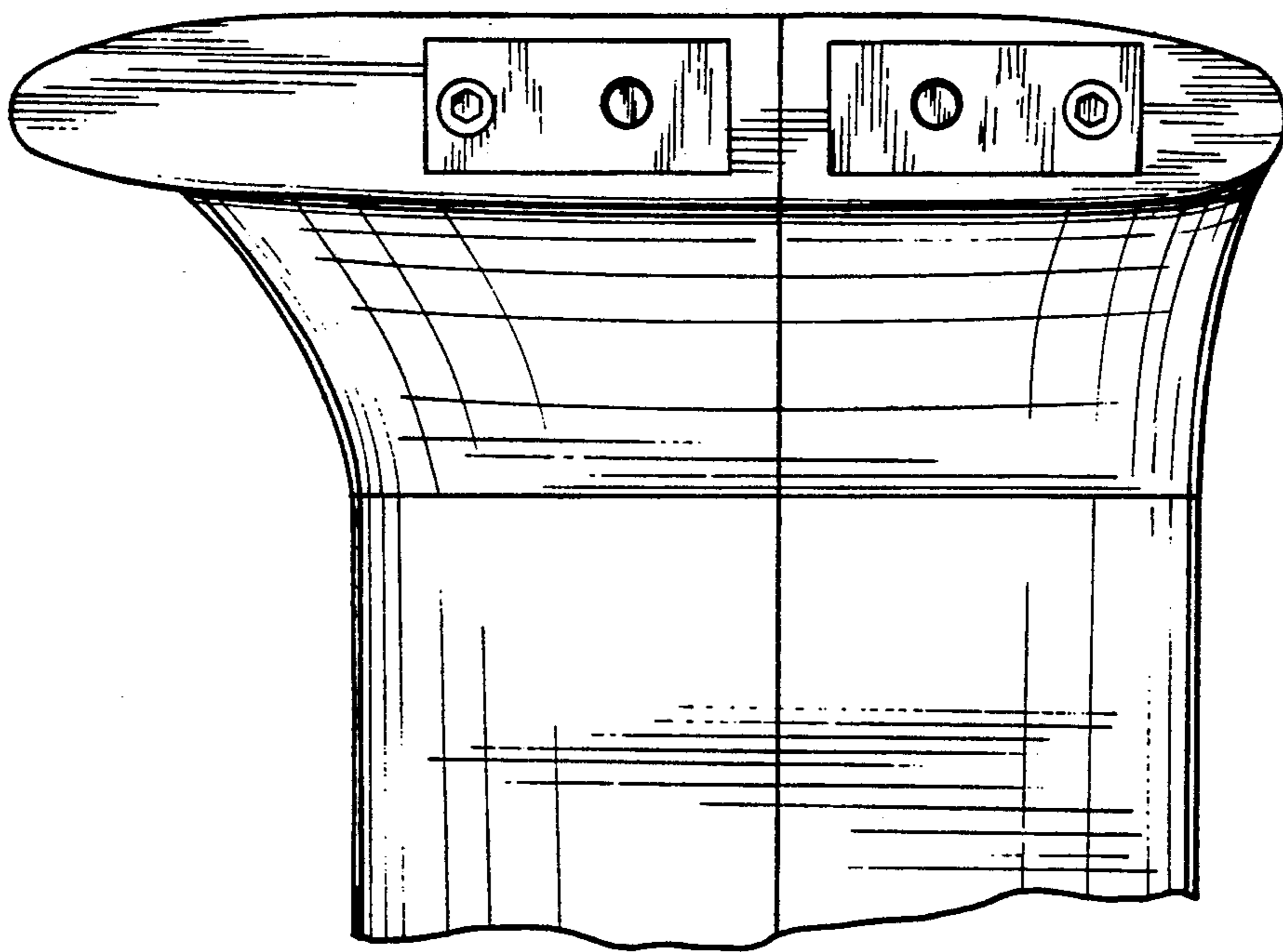

Fig-6