

[54] GUITAR BODY

[76] Inventor: E. Todd Ellison, 3203 Tareco Dr., Los Angeles, Calif. 90068

[**] Term: 14 Years

[21] Appl. No.: 150,718

[22] Filed: Feb. 1, 1988

[52] U.S. Cl. D17/20

[58] Field of Search D17/14, 18, 19, 20; 84/267, 268, 291, 293, 723, 724, 731, 733, 727, 728, 743

FOREIGN PATENT DOCUMENTS

WO87/00330 1/1987 PCT Int'l Appl. 84/267

Primary Examiner—Bernard Ansher
Assistant Examiner—Adir Aronovich
Attorney, Agent, or Firm—Charles H. Schwartz;
Ellsworth R. Roston

[57] CLAIM

The ornamental design for a guitar body, as shown and described.

DESCRIPTION

FIG. 1 is a top front perspective view of a guitar body showing my new design;
FIG. 2 is a top plan view thereof;
FIG. 3 is a front elevational view thereof;
FIG. 4 is a right side elevational view thereof;
FIG. 5 is a rear elevational view thereof;
FIG. 6 is a left side elevational view thereof; and
FIG. 7 is a bottom plan view thereof;

[56] References Cited

U.S. PATENT DOCUMENTS

D. 293,589	1/1988	Bonanno	D17/14
2,557,754	6/1951	Morrison	84/727
2,561,551	7/1951	Allen	84/723
3,911,777	10/1975	Rendell	84/743
4,254,683	3/1981	Nulman	84/743
4,616,548	10/1986	Anderson	84/743

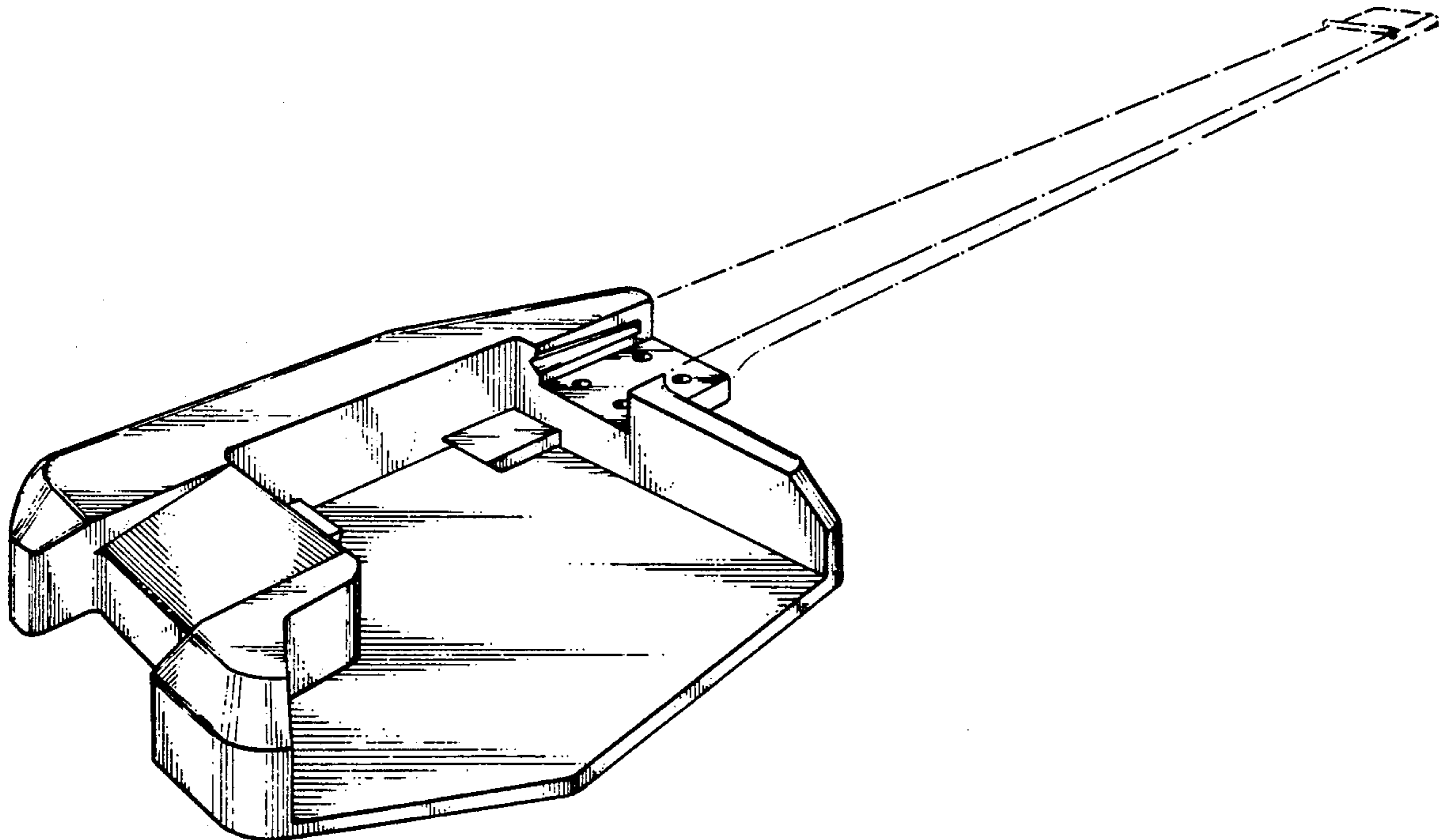

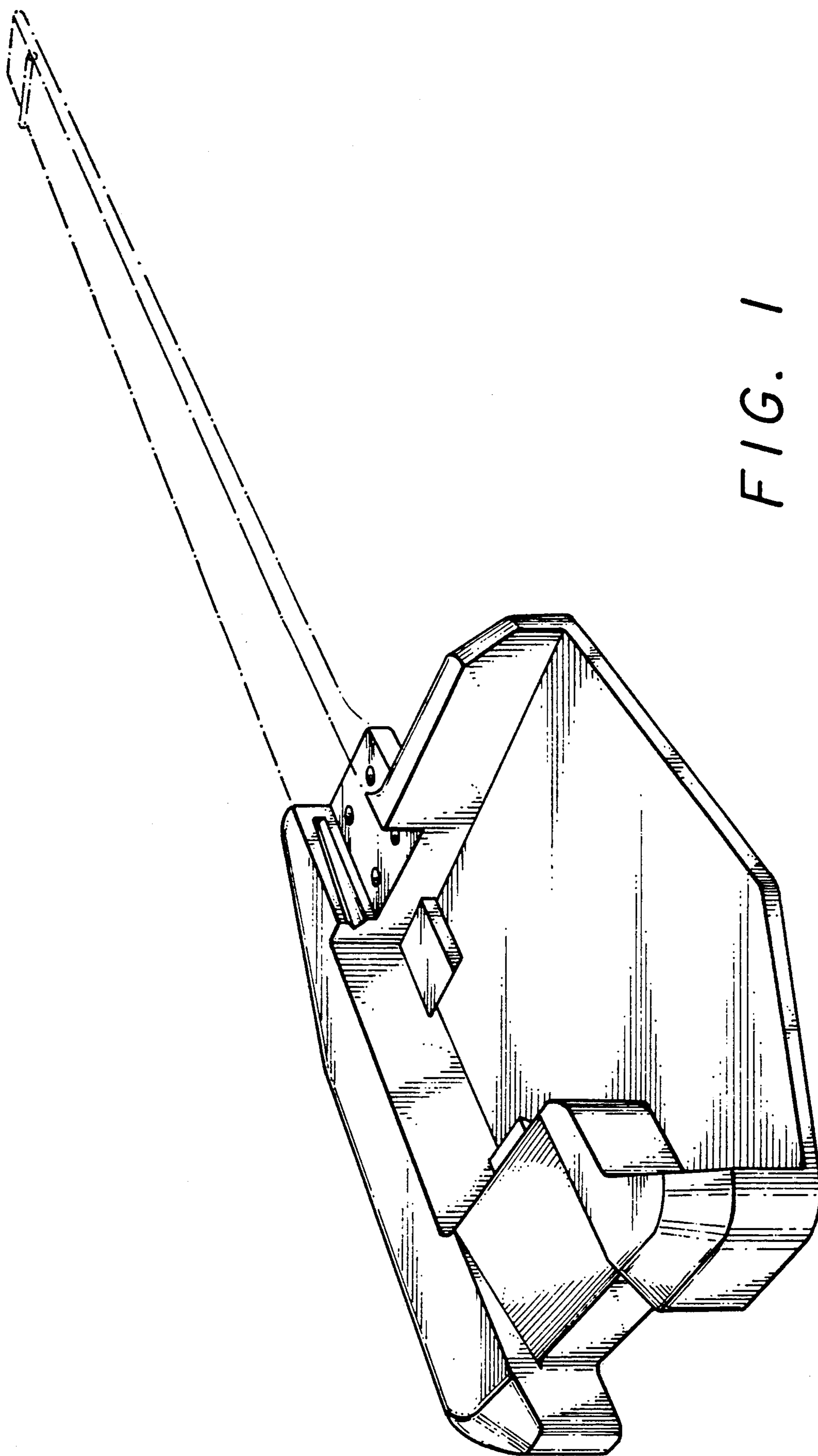
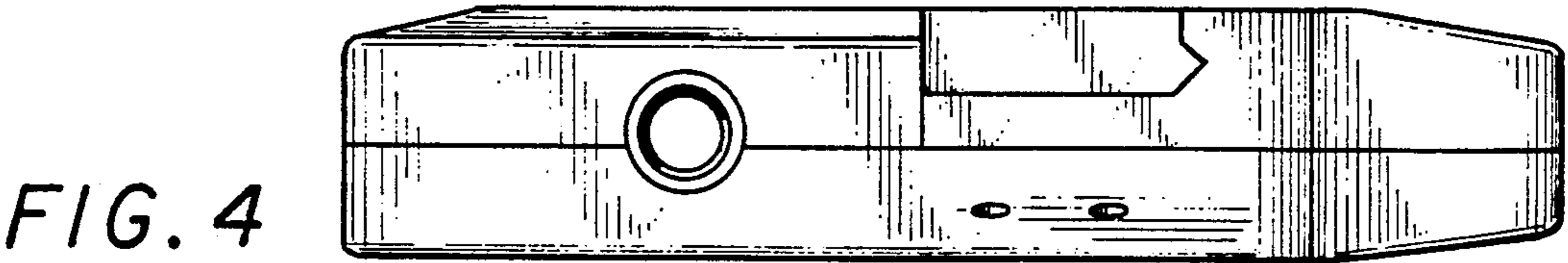
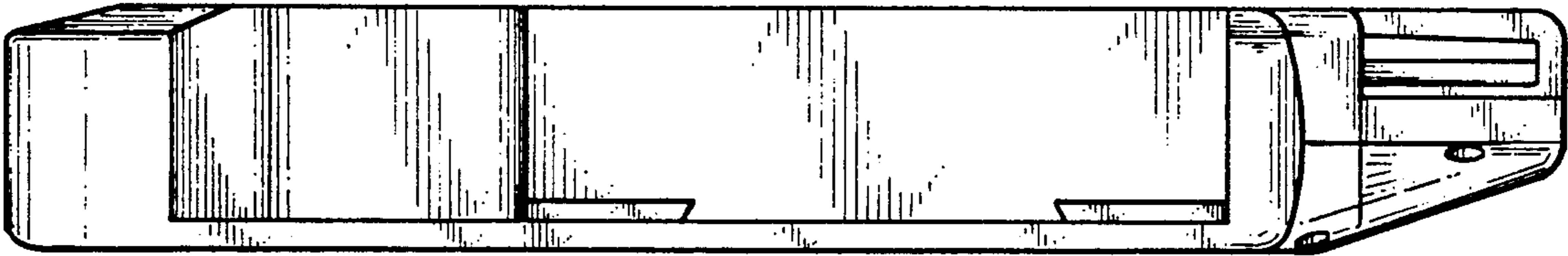
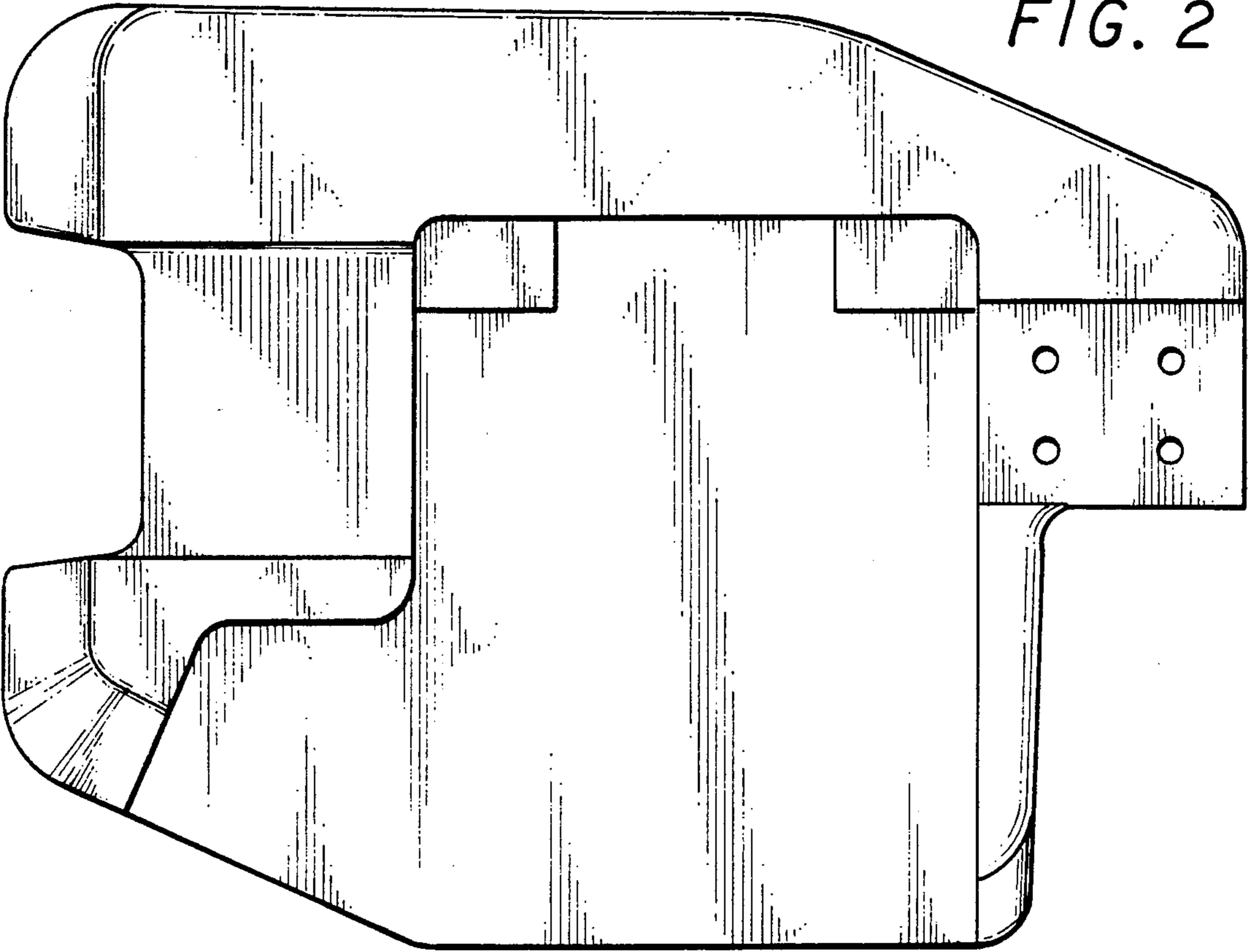

FIG. 1



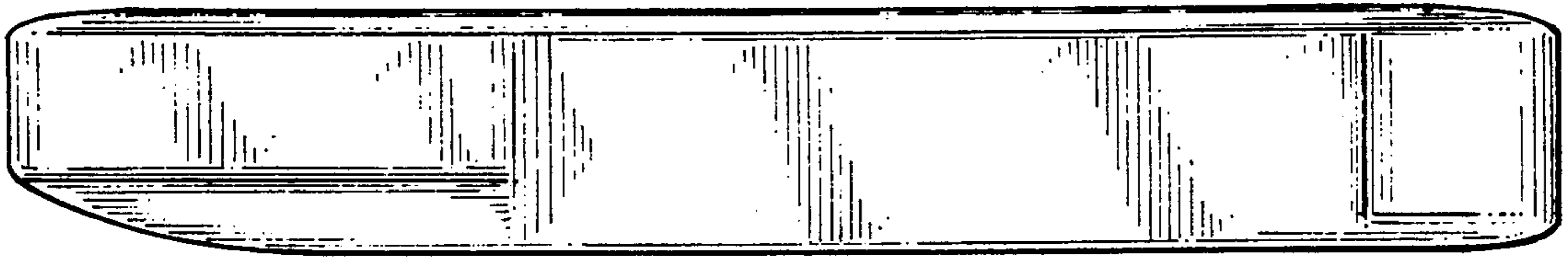

FIG. 5

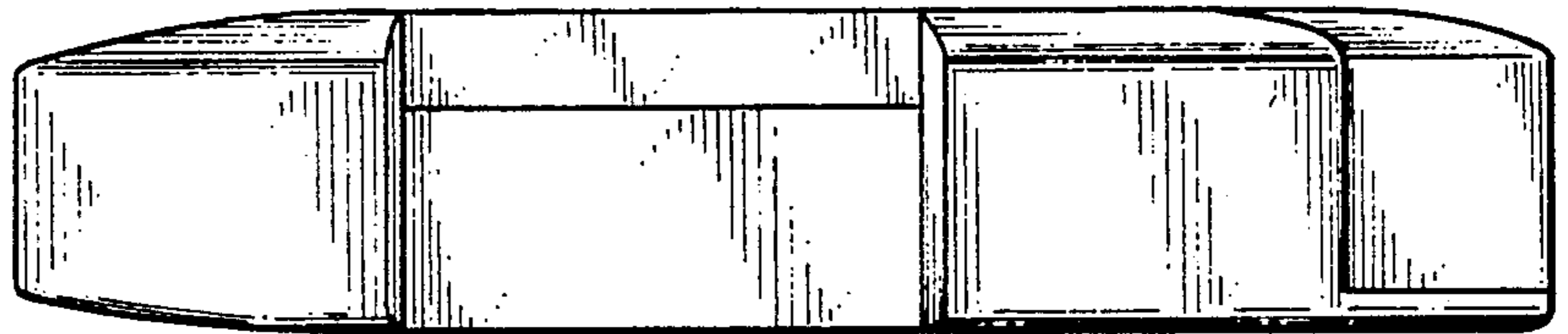

FIG. 6

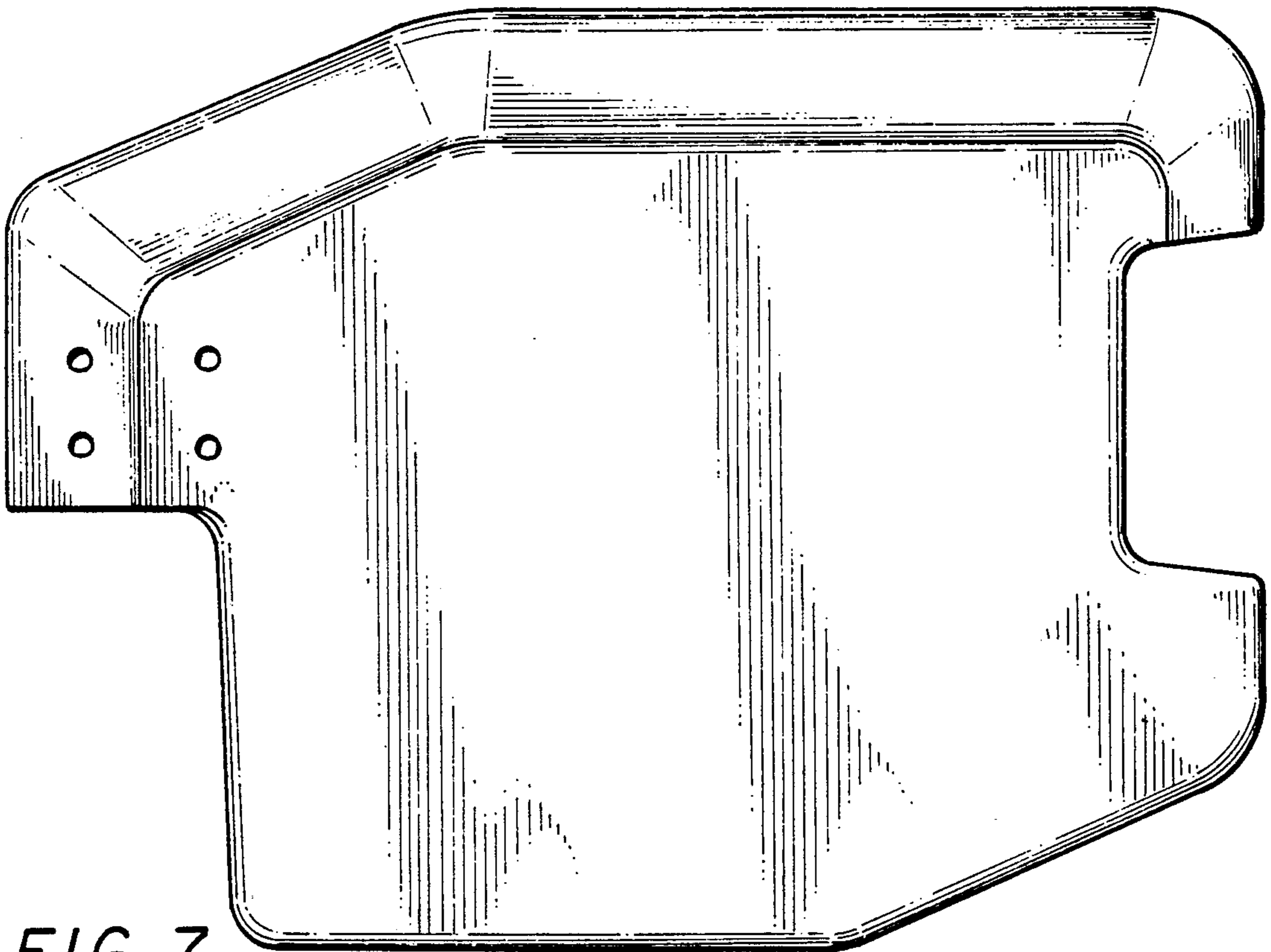

FIG. 7