

[54] **COMBINED SPRAY WAND TIP PORTION AND SWIVEL-MOUNTED NOZZLE**

[76] **Inventor: Robert W. Hengesbach**, 7886 Munson Rd., Mentor, Ohio 44060

[\*\*] **Term: 14 Years**

[21] **Appl. No.: 517,052**

[22] **Filed: Apr. 30, 1990**

**Related U.S. Application Data**

[60] Division of Ser. No. 312,238, Feb. 21, 1989, Pat. No. Des. 310,861, which is a continuation-in-part of Ser. No. 224,251, Jul. 26, 1988, abandoned, which is a continuation of Ser. No. 15,604, Feb. 17, 1987, abandoned, which is a continuation-in-part of Ser. No. 674,272, Nov. 23, 1984, Pat. No. Des. 293,127, which is a continuation-in-part of Ser. No. 461,874, Jan. 28, 1983, Pat. No. Des. 282,392.

[52] **U.S. Cl. .... D23/213**

[58] **Field of Search .... D23/213, 223-227; 406/152; 141/19; 251/231; 294/25-26; 239/8, 134, 337, 525-526, 532**

[56] **References Cited**

**U.S. PATENT DOCUMENTS**

D. 183,042	6/1958	Fuglie et al. ....	D91/3
D. 212,610	11/1964	Wahlin .....	D23/226
D. 234,845	4/1975	Davis .....	D23/1
D. 243,532	3/1977	Fyffe .....	D23/223
D. 254,146	2/1980	Koenig .....	D23/19
D. 254,322	2/1980	Koenig .....	D23/19
D. 257,537	11/1980	Chow et al. ....	D23/226
D. 270,368	8/1983	Grime .....	D23/1
D. 282,392	1/1986	Hengesbach .....	D23/17
D. 284,301	6/1986	Hengesbach .....	D23/17
D. 285,242	8/1986	Hengesbach .....	D23/17
D. 285,477	9/1986	Hengesbach .....	D23/18
D. 285,478	9/1986	Hengesbach .....	D23/19
D. 285,479	9/1986	Hengesbach .....	D23/20
D. 288,229	2/1987	Beal et al. ....	D23/43
D. 293,127	12/1987	Hengesbach .....	D23/226
336,602	2/1886	Tomlinson .	
370,836	10/1887	Wilkins .	
511,728	12/1893	Deming .	
564,500	7/1896	Benedict et al. .	
676,526	6/1901	Anderson .	
915,694	3/1909	Pendergrass .	

949,489	2/1910	Mastin .	
1,605,617	11/1926	Ruemelin .	
1,743,537	1/1930	Freese .	
2,072,555	3/1937	Hengesbach et al. ....	122/144
2,157,269	5/1939	Richter .....	158/27.4
2,293,390	8/1942	Hengesbach .....	299/84
2,333,727	9/1945	Lucas .....	47/49
2,366,969	1/1945	Kiggins .....	299/140
2,421,103	5/1947	Wadsworth .....	285/209
2,421,104	5/1947	Wadsworth .....	285/97.5
2,564,938	8/1951	Warren .....	285/95
2,657,098	10/1953	Straham .....	299/131
2,783,092	2/1957	Gavin et al. ....	299/116
2,788,926	4/1957	Morrison .....	222/394
2,890,067	6/1959	Morin .....	285/166
2,929,406	3/1960	Anderson .....	137/615
3,116,882	1/1964	Vork .....	239/587
3,202,360	8/1965	O'Brien .....	239/119
3,319,893	5/1967	Rodgers et al. ....	239/393
3,475,039	10/1969	Ortloff .....	285/45
3,556,411	1/1971	Nord et al. ....	239/581
3,632,046	1/1972	Hengesbach .....	239/318
3,711,028	1/1973	Hengesbach .....	239/288.5
3,727,841	4/1973	Hengesbach .....	239/145
3,756,273	9/1973	Hengesbach .....	137/540
3,814,329	6/1974	Clark .....	239/426
3,955,763	5/1976	Pyle et al. ....	239/119
4,035,004	7/1977	Hengesbach .....	285/166
4,206,877	6/1980	Hoza, III .....	239/524
4,449,696	5/1984	Hengesbach .....	251/231
4,473,328	9/1984	Hengesbach .....	406/152
4,531,675	7/1985	Muck .....	239/290
4,569,160	2/1986	Hengesbach .....	51/427
4,629,121	12/1986	Hengesbach .....	239/119

**FOREIGN PATENT DOCUMENTS**

874866	7/1971	Canada .	
937262	11/1973	Canada .	
952559	8/1974	Canada .	
998716	10/1976	Canada .	
1029422	4/1978	Canada .....	299/15
1040236	10/1978	Canada .....	299/15
1045657	1/1979	Canada .	
2266070	10/1976	France .	

**OTHER PUBLICATIONS**

Brochure, Tri-Con, Inc., 4 pages, dated 1/1/1977, entitled: We Make the System.  
 Brochure, Spraying Systems Co., Catalog 27, pp. 75-79, 1978, entitled: Spray Nozzles and Accessories.

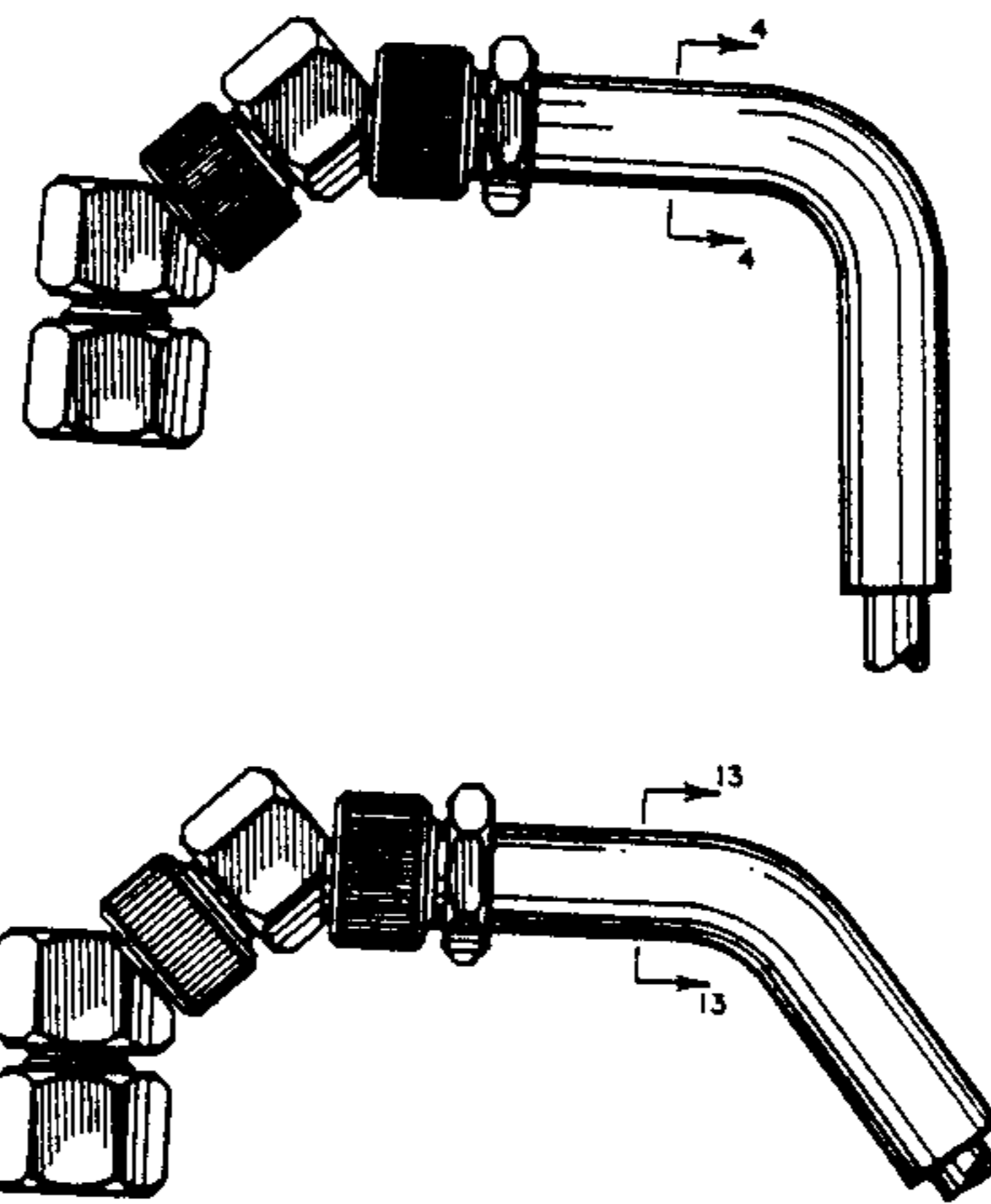

Brochure, Spraying Systems Co., Bulletin 179F, 7 pages, 1971, entitled: Spray Nozzles, Spray Guns, Valves and Accessories.

Brochure, Tri-Con, Inc., 2 pages, date unknown, entitled: Tri-Con Rust-Fighter Vehicle Inner-Body Coating System 9000.

Brochure, Tri-Con, 4 pages, date unknown, entitled: The Tri-Con All Purpose Nozzle.

*Primary Examiner*—Wallace R. Burke

*Assistant Examiner*—Brian N. Vinson

*Attorney, Agent, or Firm*—David A. Burge

[57]

**CLAIM**

The ornamental design for a combined spray wand tip portion and swivel-mounted nozzle, as shown and described.

**DESCRIPTION**

FIG. 1 is a right side elevational view of a combined spray wand tip portion and swivel-mounted nozzle showing my new design, the left side being a mirror image of that shown;

FIG. 2 is a front elevational view thereof;

FIG. 3 is a rear elevational view thereof;

FIG. 4 is a fragmentary vertical cross-sectional view thereof, taken along line 4—4 of FIG. 1, with portions omitted for convenience of illustration;

FIG. 5 is a top plan view thereof;

FIG. 6 is a bottom plan view thereof;

FIG. 7 is a right side elevational view thereof, with the nozzle portion shown swiveled to an alternate position;

FIG. 8 is a right side elevational view thereof, with the

nozzle portion shown swiveled to another alternate position;

FIG. 9 is a right side elevational view thereof, with the nozzle portion shown swiveled to a further alternate position;

FIG. 10 is a right side elevational view of an alternate embodiment thereof, the left side being a mirror image of that shown;

FIG. 11 is a front elevational view of the embodiment of FIG. 10;

FIG. 12 is a rear elevational view of the embodiment of FIG. 10;

FIG. 13 is a fragmentary vertical cross-sectional view of the embodiment of FIG. 10, taken along line 13—13 of FIG. 10, with portions omitted for convenience of illustration;

FIG. 14 is a top plan view of the embodiment of FIG. 10;

FIG. 15 is a bottom plan view of the embodiment of FIG. 10;

FIG. 16 is a right side elevational view of the embodiment of FIG. 10, with the nozzle portion shown swiveled to an alternate position;

FIG. 17 is a right side elevational view of the embodiment of FIG. 10, with the nozzle portion shown swiveled to another alternate position; and

FIG. 18 is a right side elevational view of the embodiment of FIG. 10, with the nozzle portion shown swiveled to a further alternate position.

The ends of the wand portions are shown broken-away in FIGS. 7-9 and 16-18 for convenience of illustration.

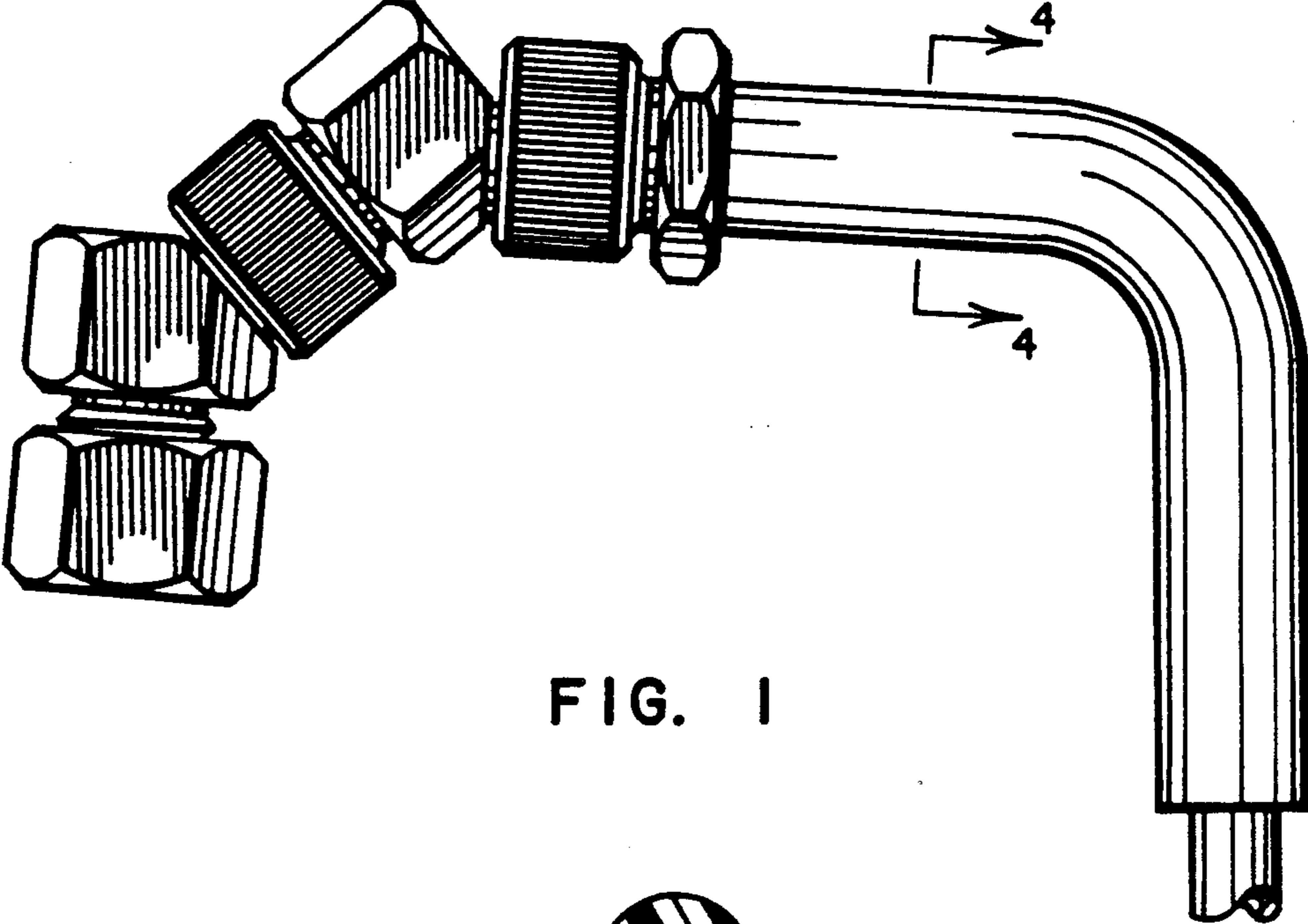

FIG. 1



FIG. 4

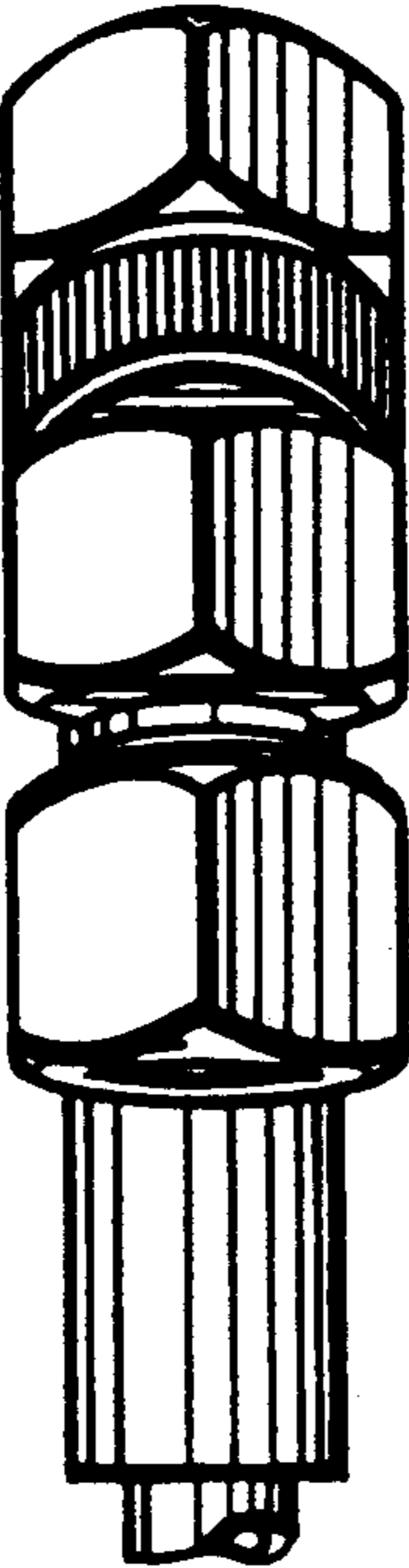

FIG. 2

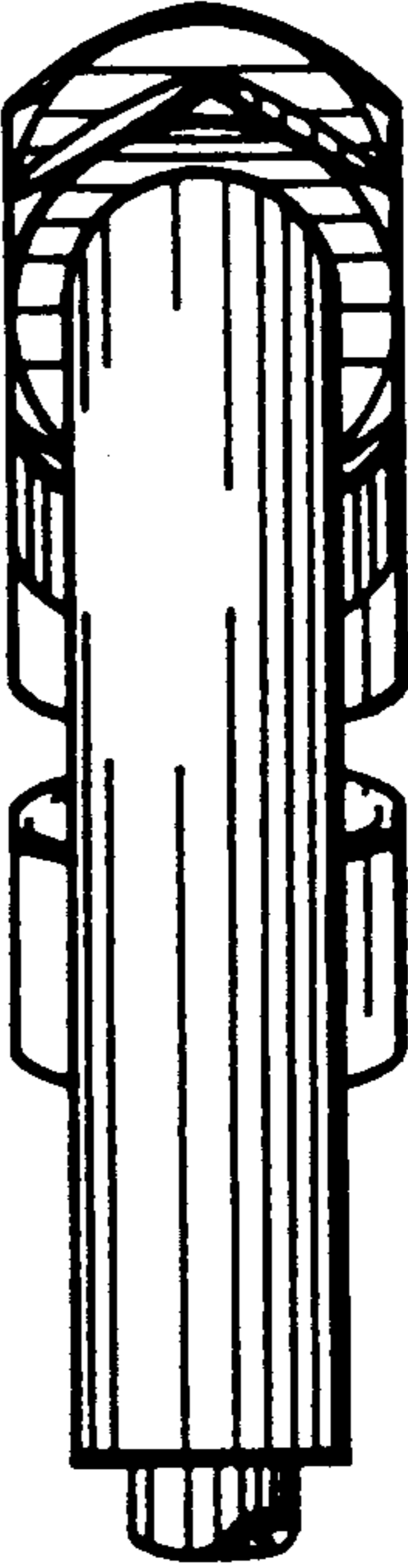

FIG. 3

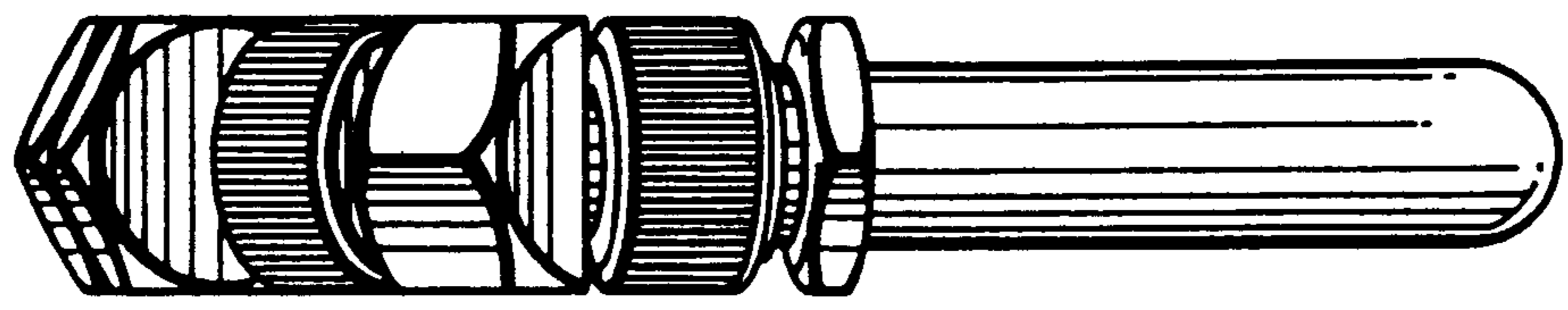

FIG. 5

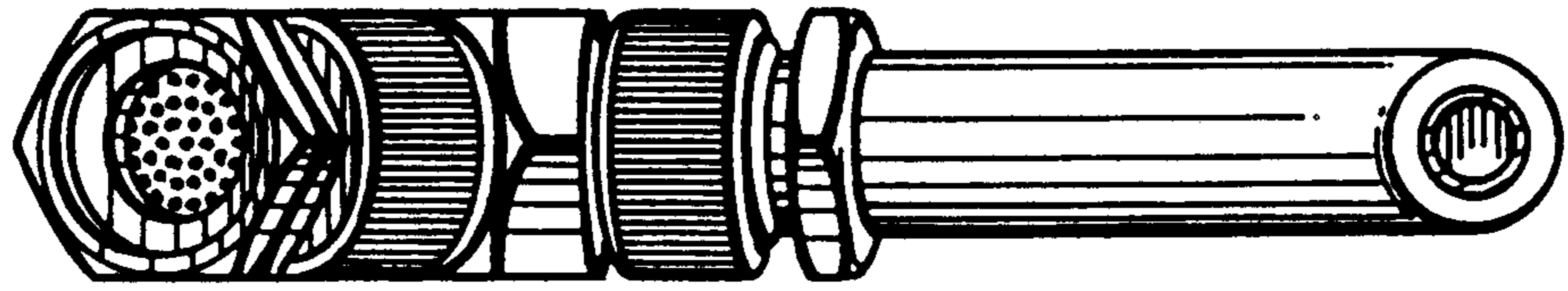

FIG. 6

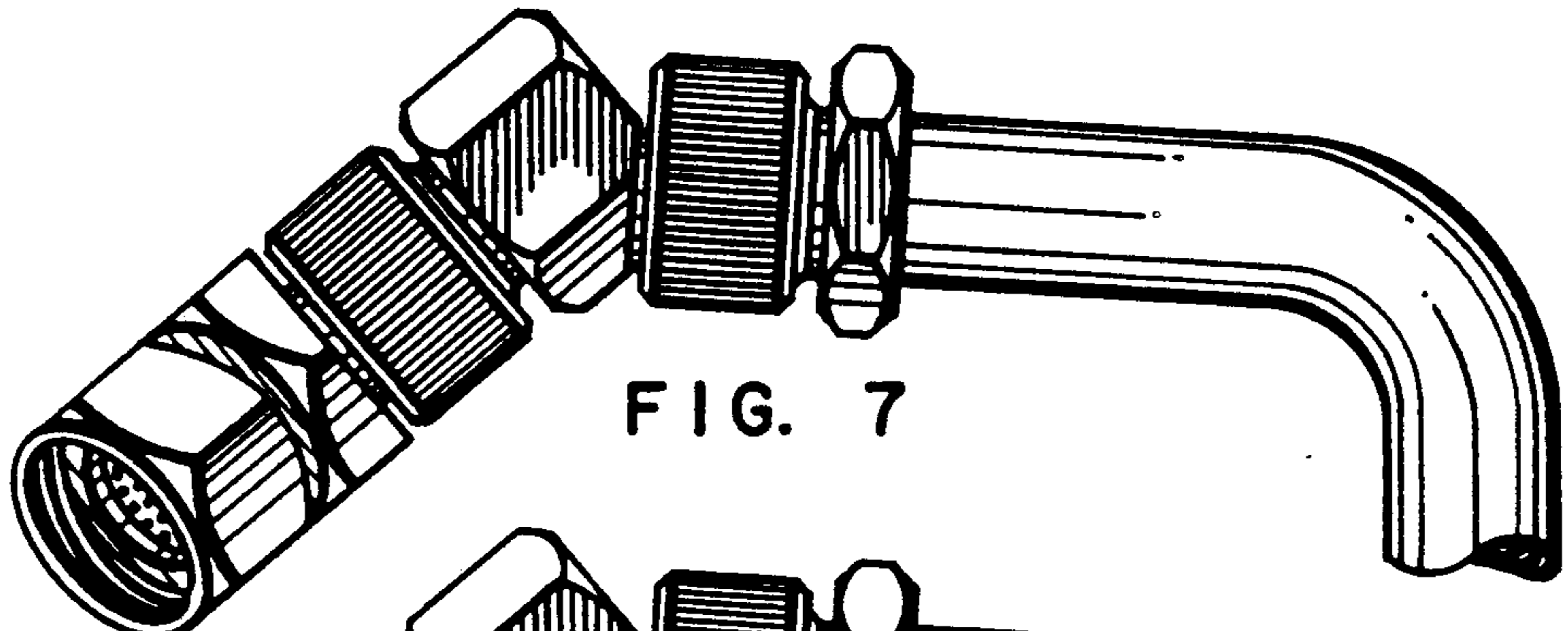

FIG. 7

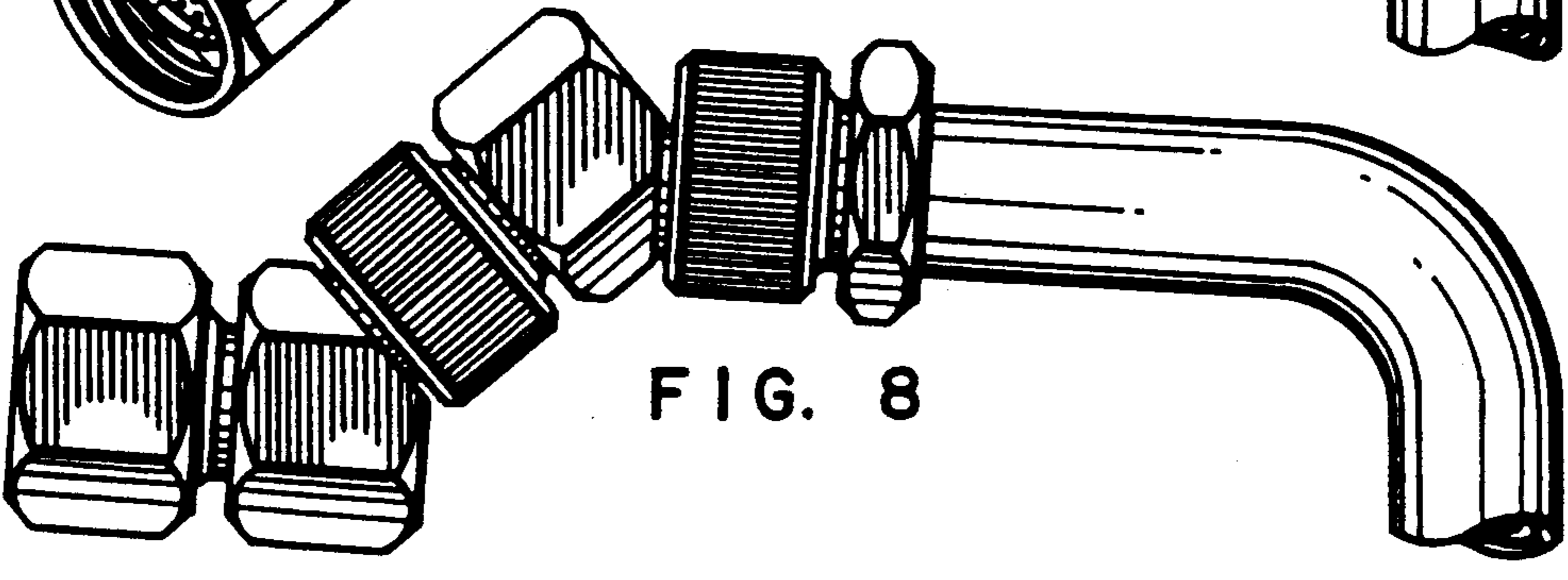

FIG. 8

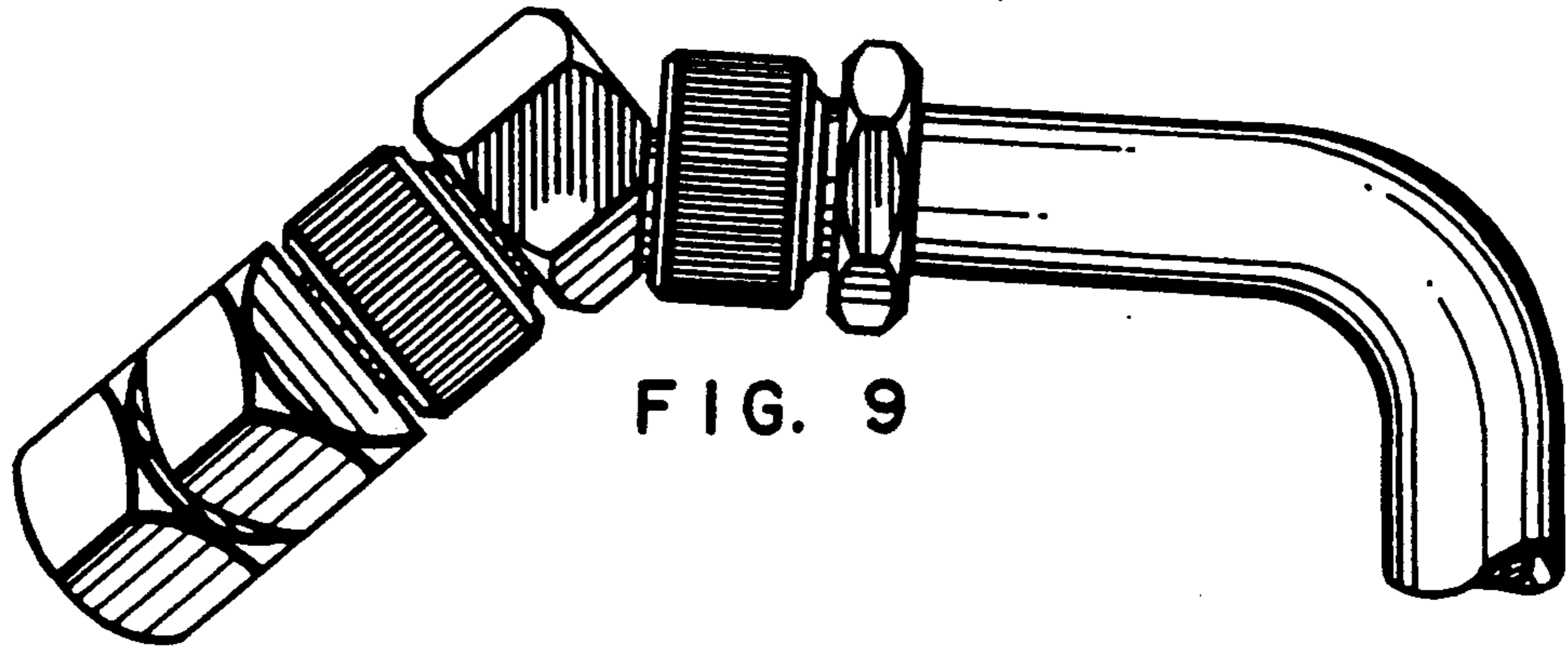

FIG. 9

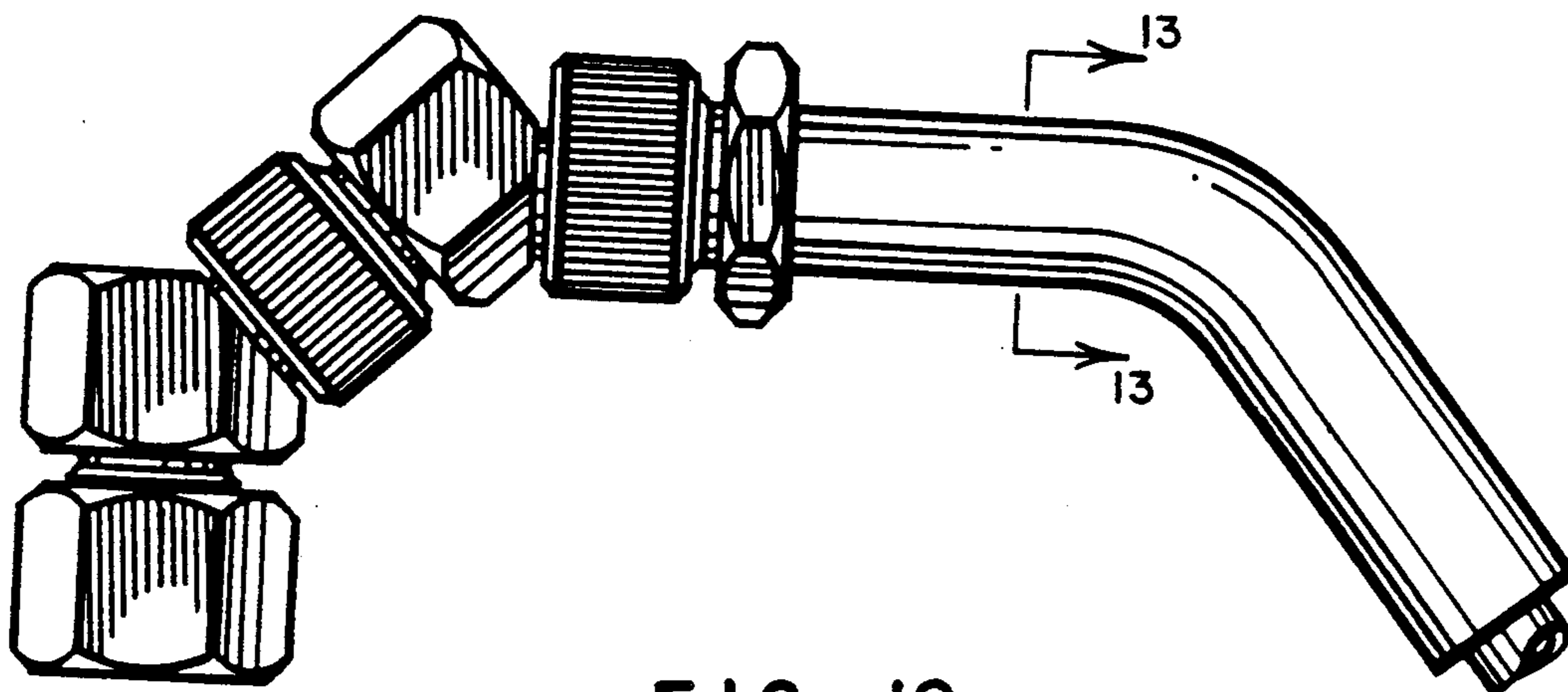

FIG. 10

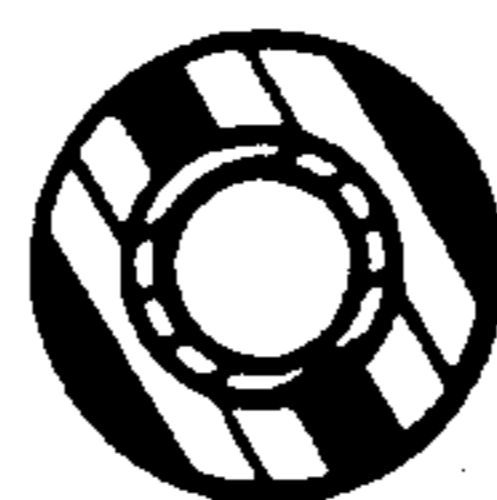

FIG. 13

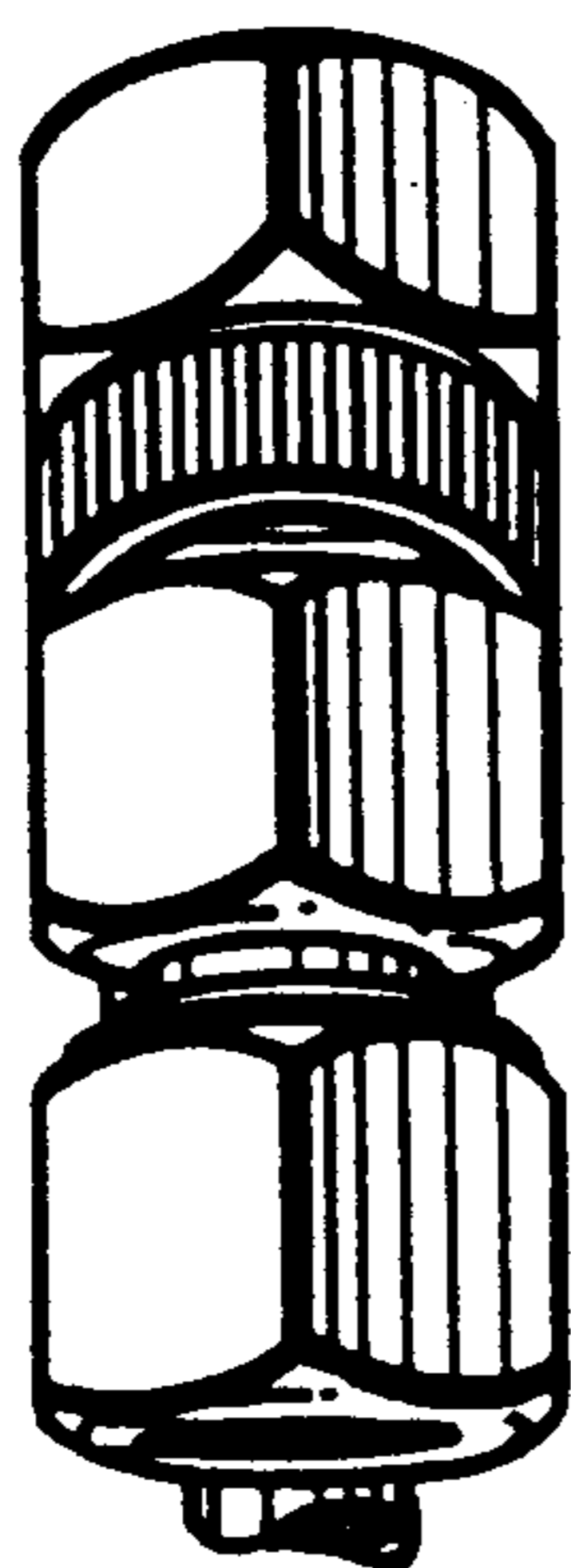

FIG. 11

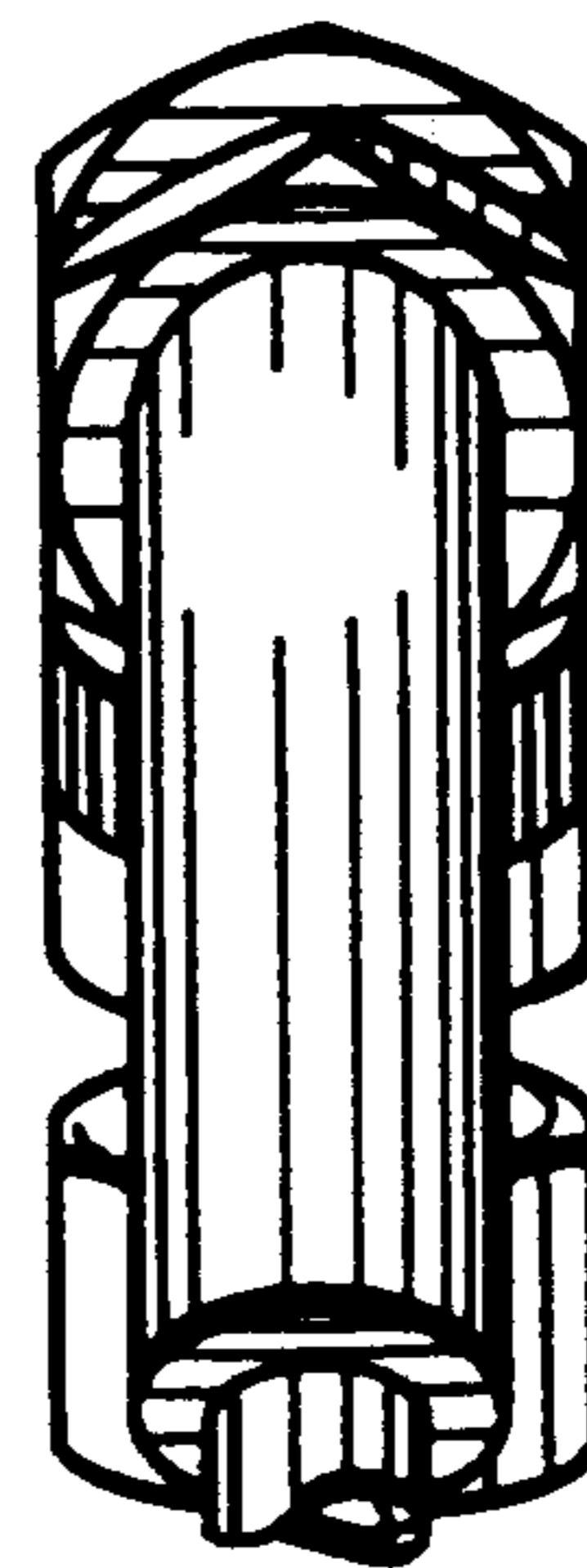

FIG. 12

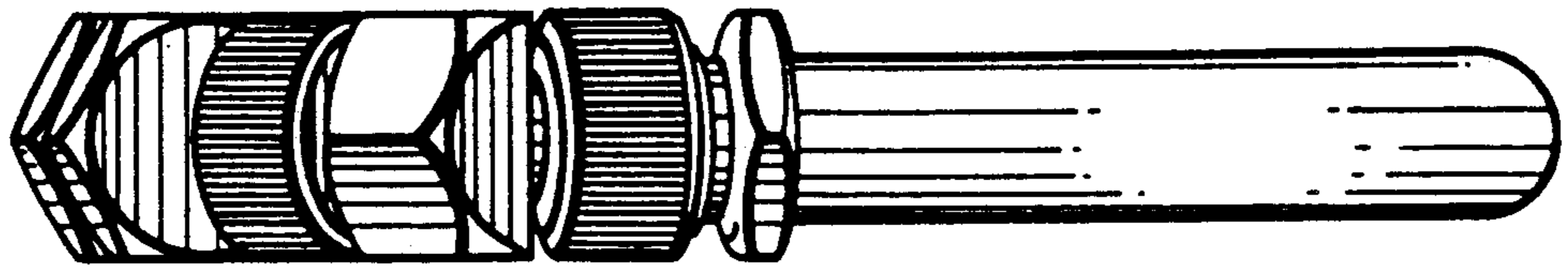

FIG. 14

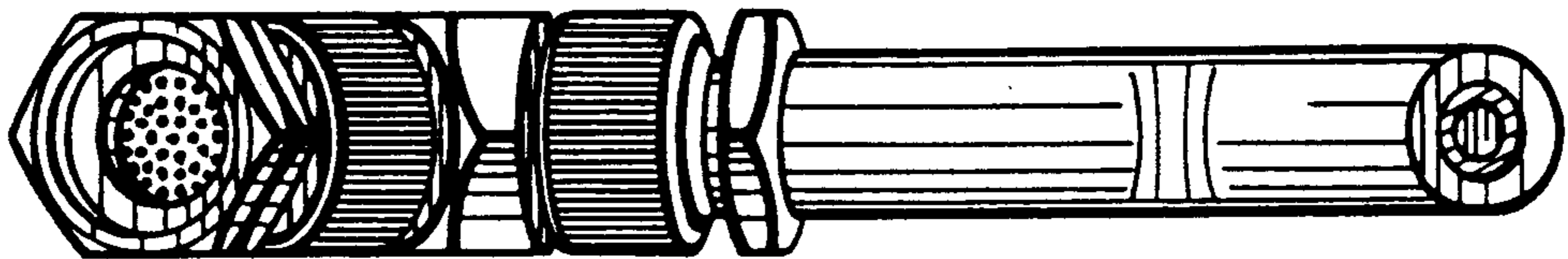

FIG. 15

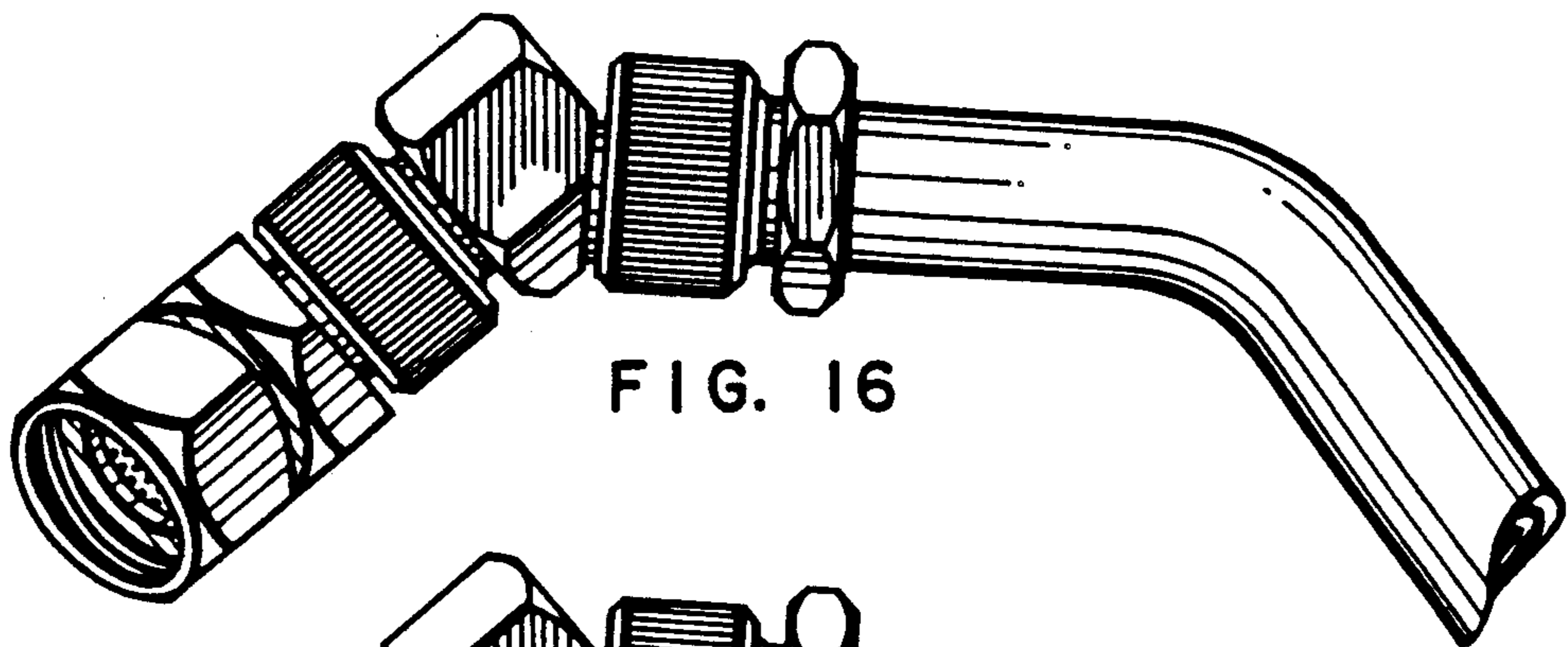

FIG. 16

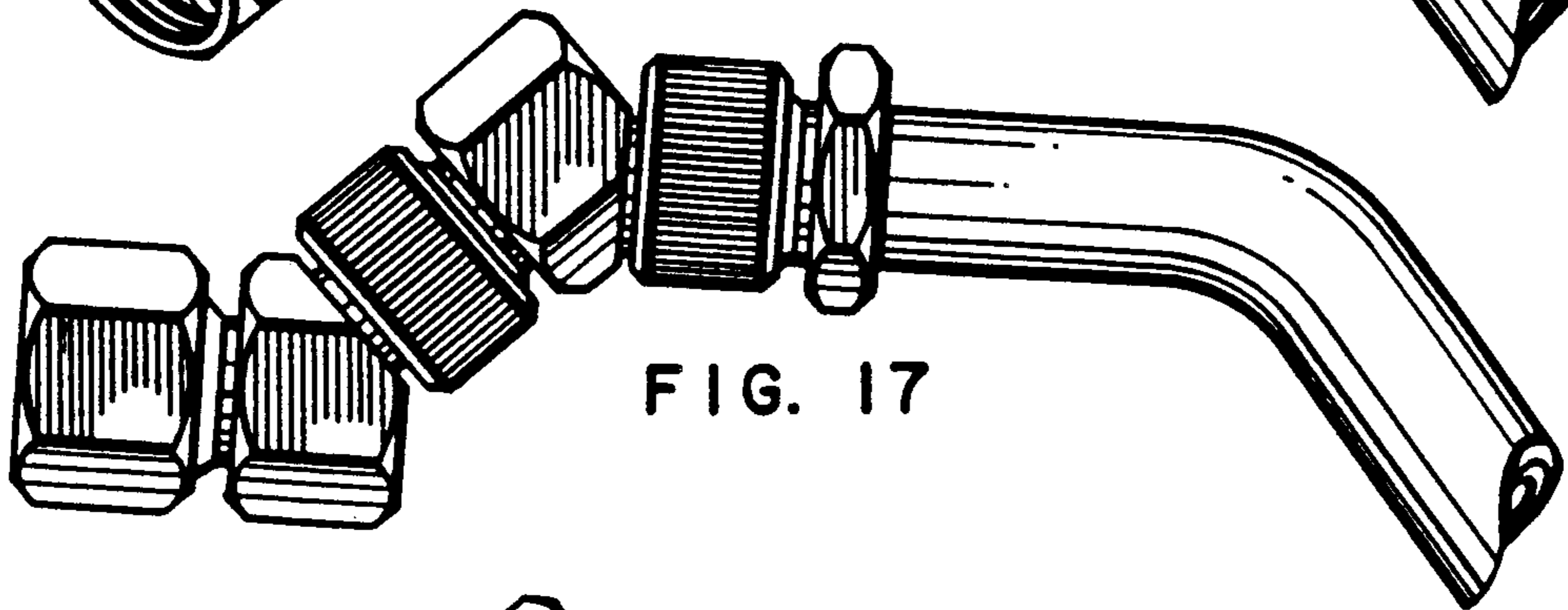

FIG. 17

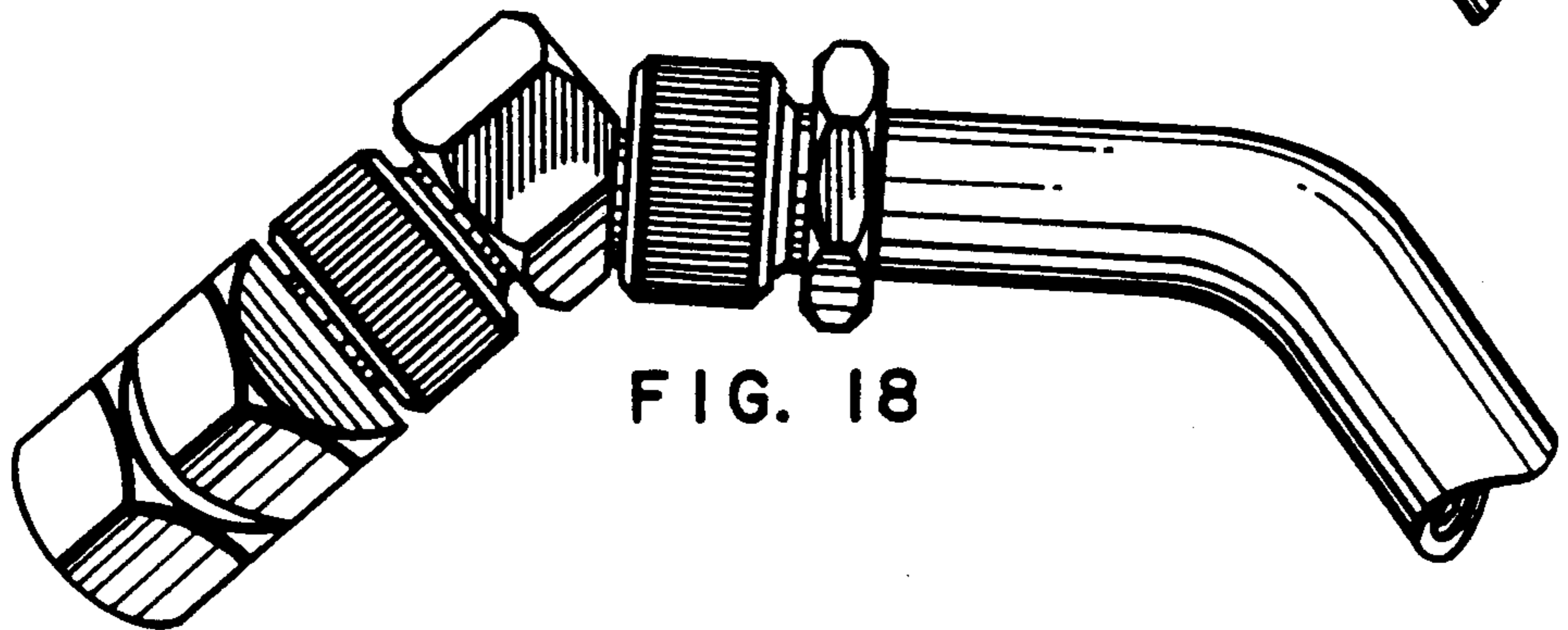

FIG. 18