

[54] DIGITAL-ANALOG CONVERTER

[56] References Cited

[75] Inventors: Masafumi Ito, Tokyo; Shigeru Hasegawa, Kodaira; Haruki Takita; Minoru Sube, both of Hachioji, all of Japan

U.S. PATENT DOCUMENTS

D. 265,091 6/1982 Hutcheson D14/107
D. 286,049 10/1986 Nishida D14/107
D. 290,961 7/1987 Mendel D14/107
D. 291,443 8/1987 Pardinielli et al. D14/107

[73] Assignee: Teac Corporation, Tokyo, Japan

Primary Examiner—Wallace R. Burke
Assistant Examiner—Freda S. Nunn
Attorney, Agent, or Firm—Ladas & Parry

[**] Term: 14 Years

[57] CLAIM

The ornamental design for a digital-analog converter, as shown and described.

[21] Appl. No.: 154,598

DESCRIPTION

[22] Filed: Feb. 10, 1988

FIG. 1 is a top plan view of a digital-analog converter showing our new design;
FIG. 2 is a front elevational view thereof;
FIG. 3 is a left side elevational view thereof;
FIG. 4 is a right side elevational view thereof;
FIG. 5 is a bottom plan view thereof;
FIG. 6 is a rear elevational view thereof;
FIG. 7 is a top, front, right side perspective view thereof;
FIG. 8 is a vertical cross sectional view taken along lines 8—8 of FIG. 1.

[30] Foreign Application Priority Data

Aug. 24, 1987 [JP] Japan 62-34370
[52] U.S. Cl. D14/100; D14/107
[58] Field of Search D14/100-117;
D13/40, 41; 360/97-99; 361/390-395, 331,
380, 381; 174/52.1; 312/138.1, 208; 200/5 A, 5
R, 6 A, 6 R

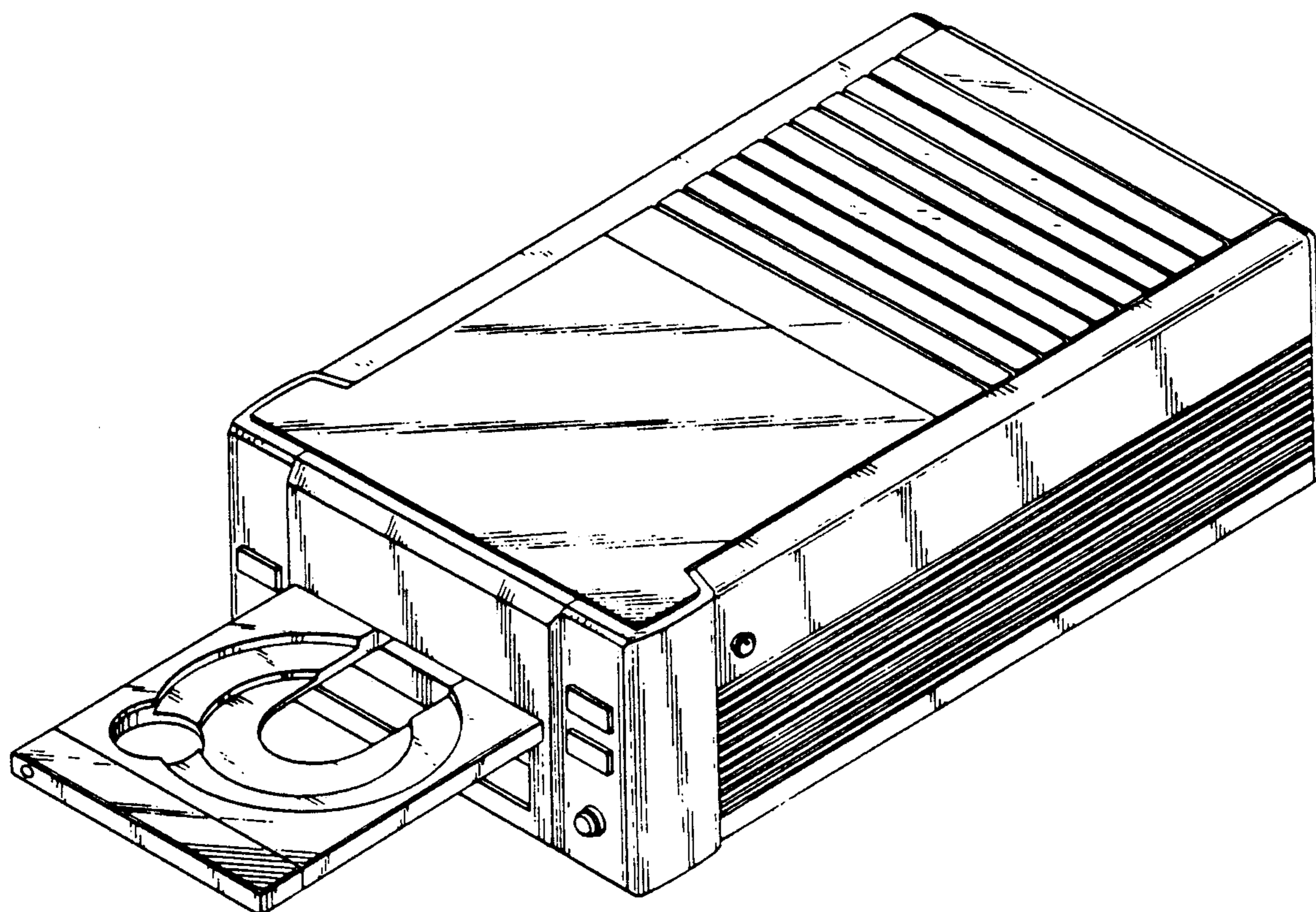

FIG. 1

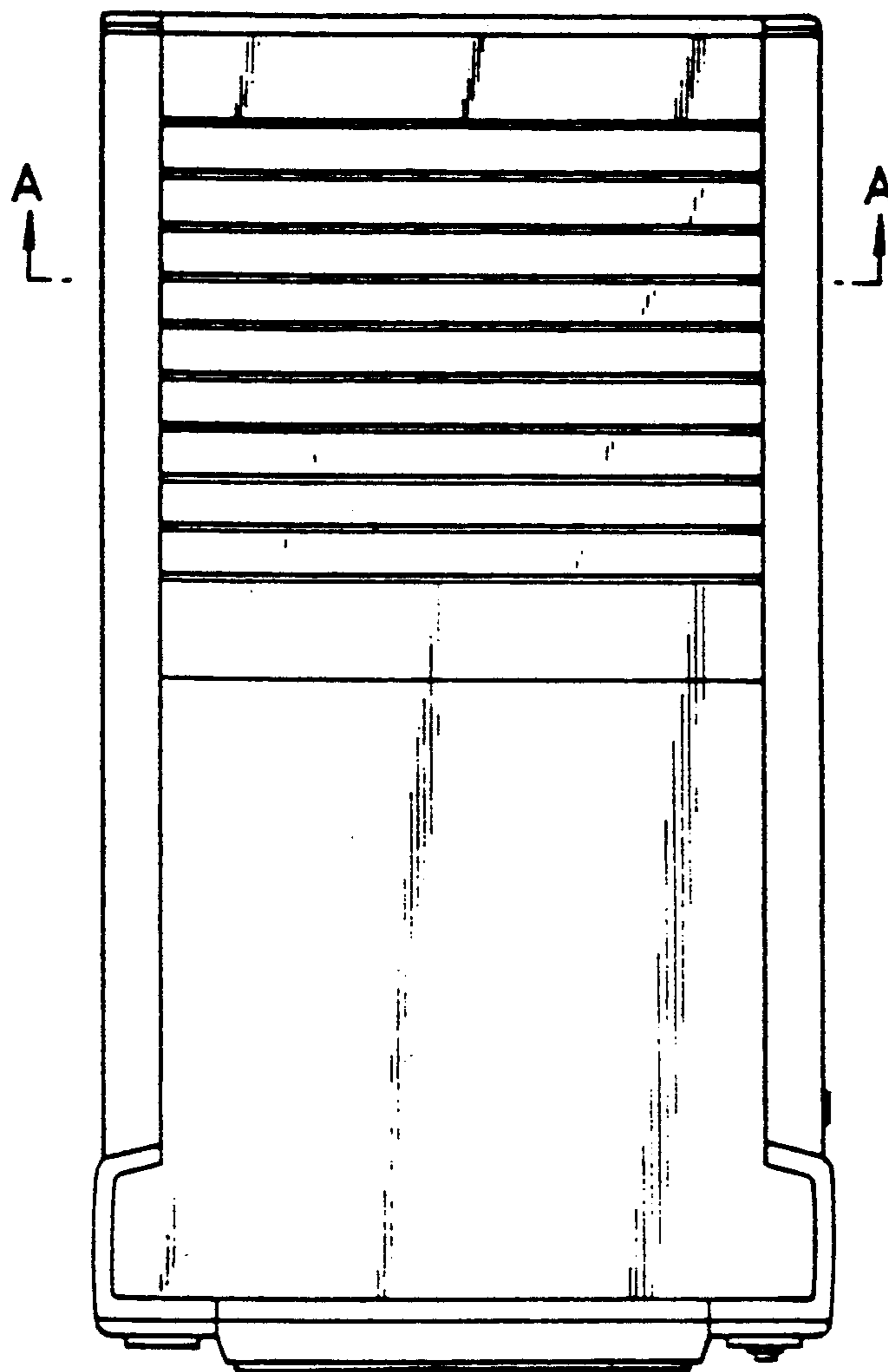

FIG. 2

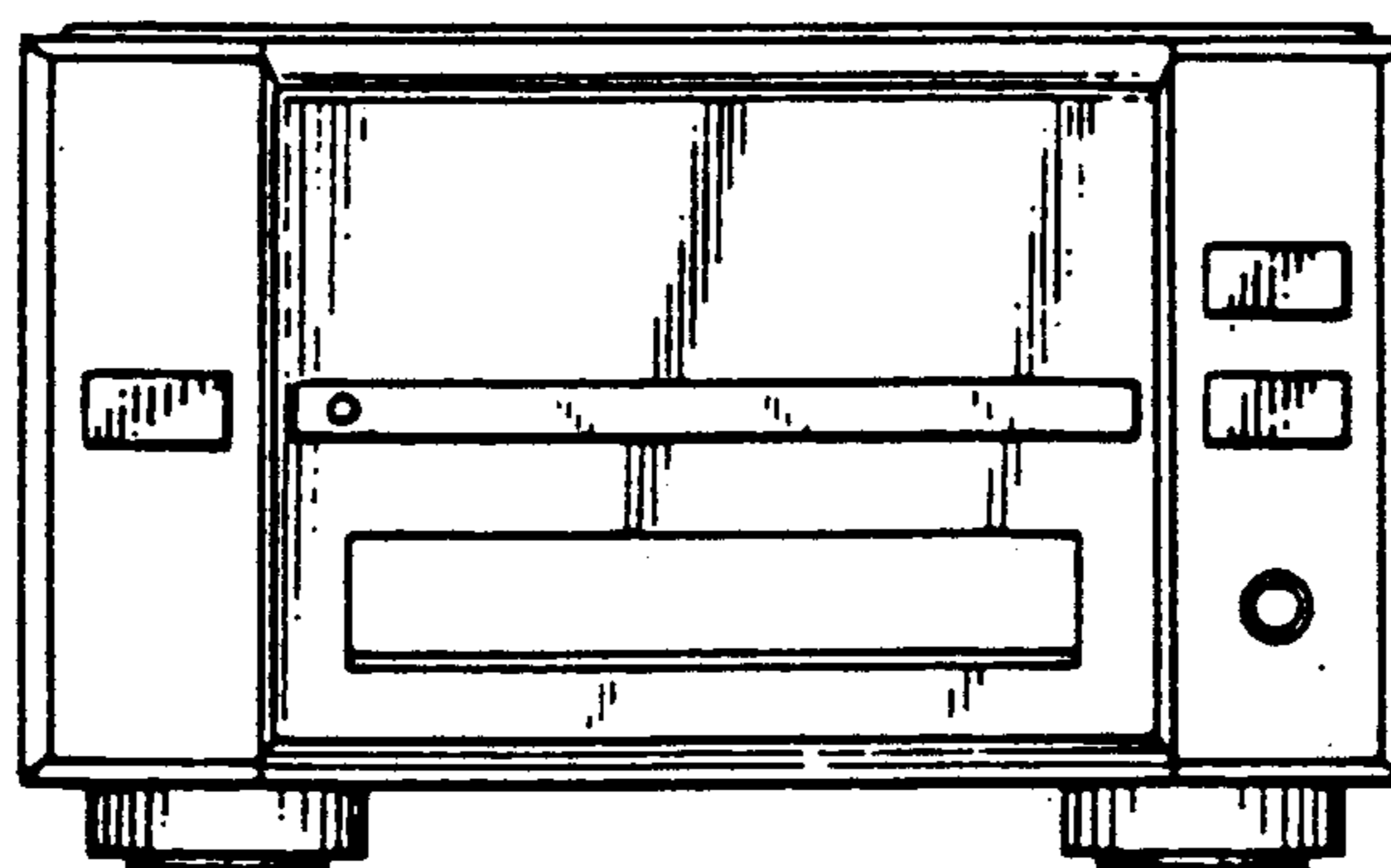

FIG. 3

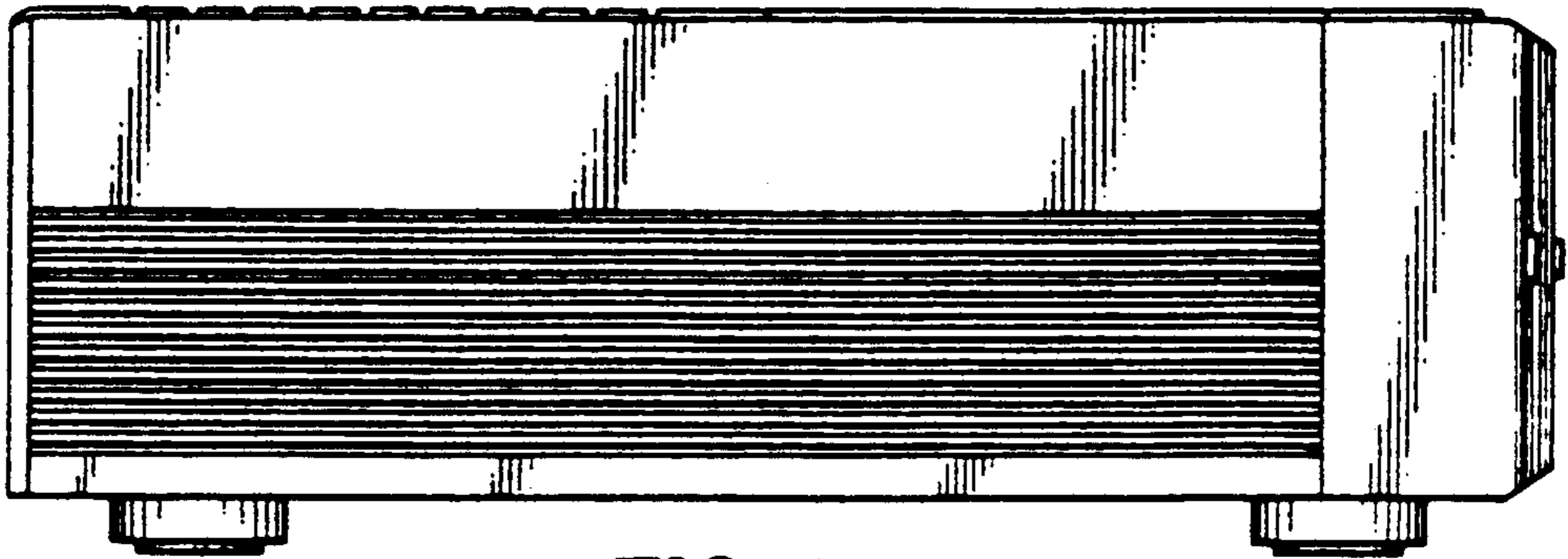

FIG. 4

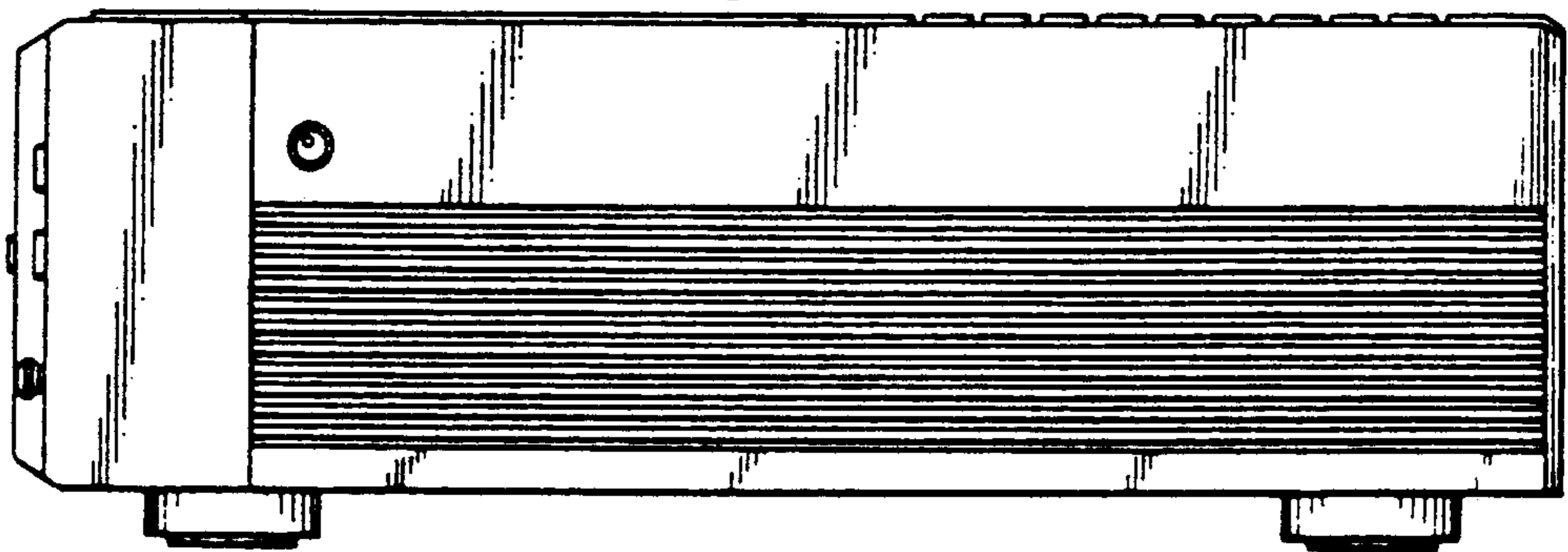

FIG. 5

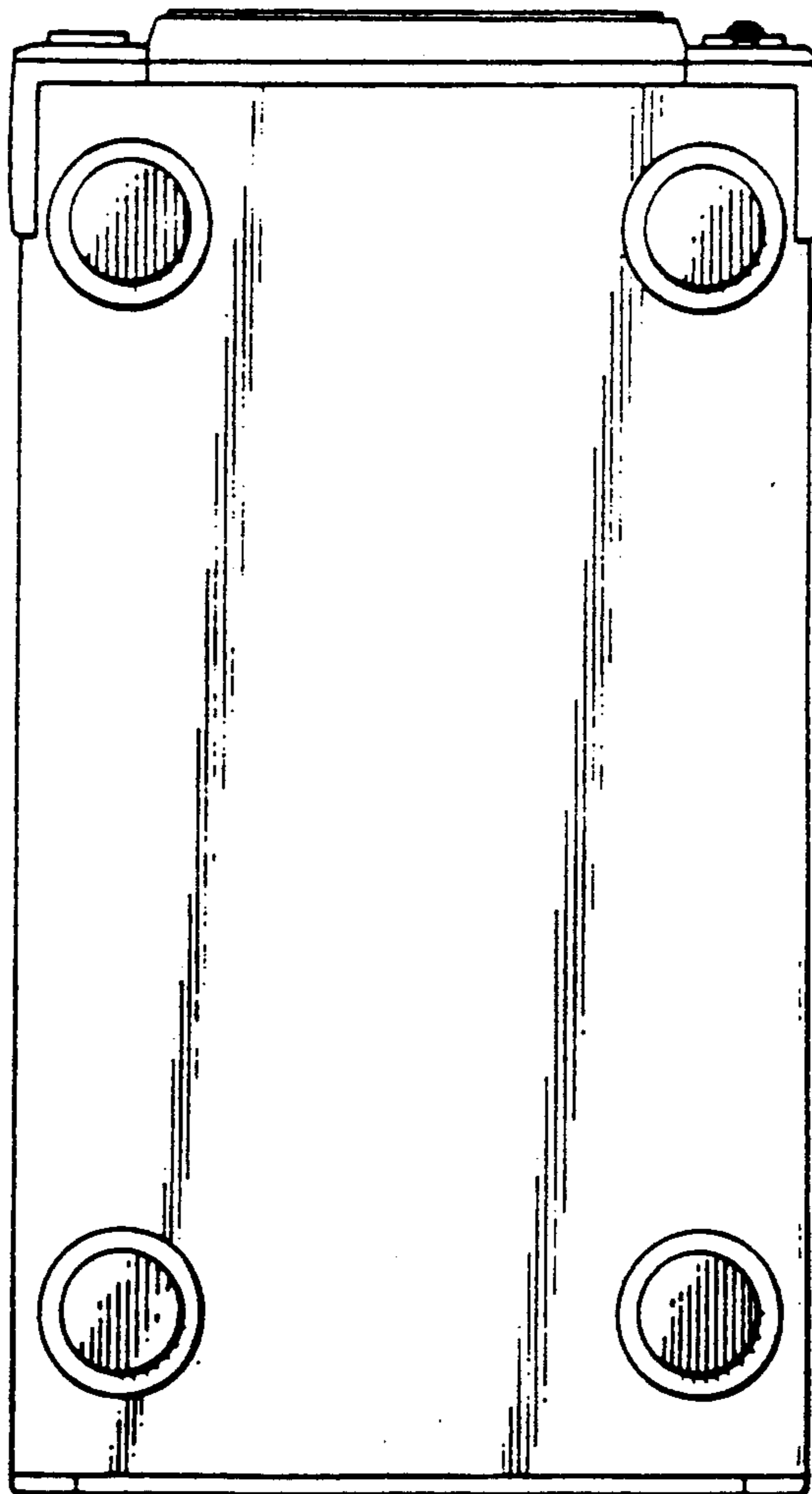

FIG. 6

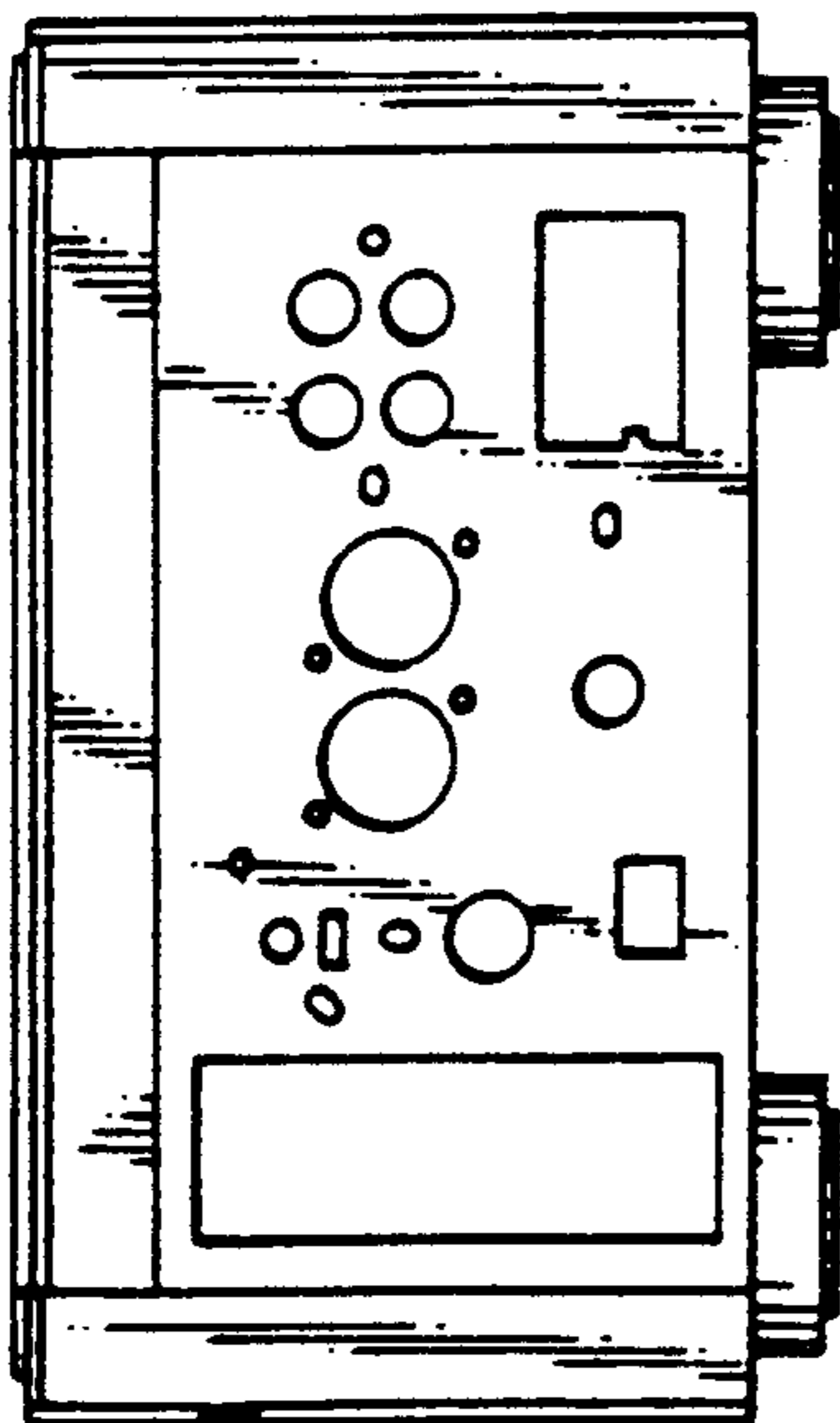
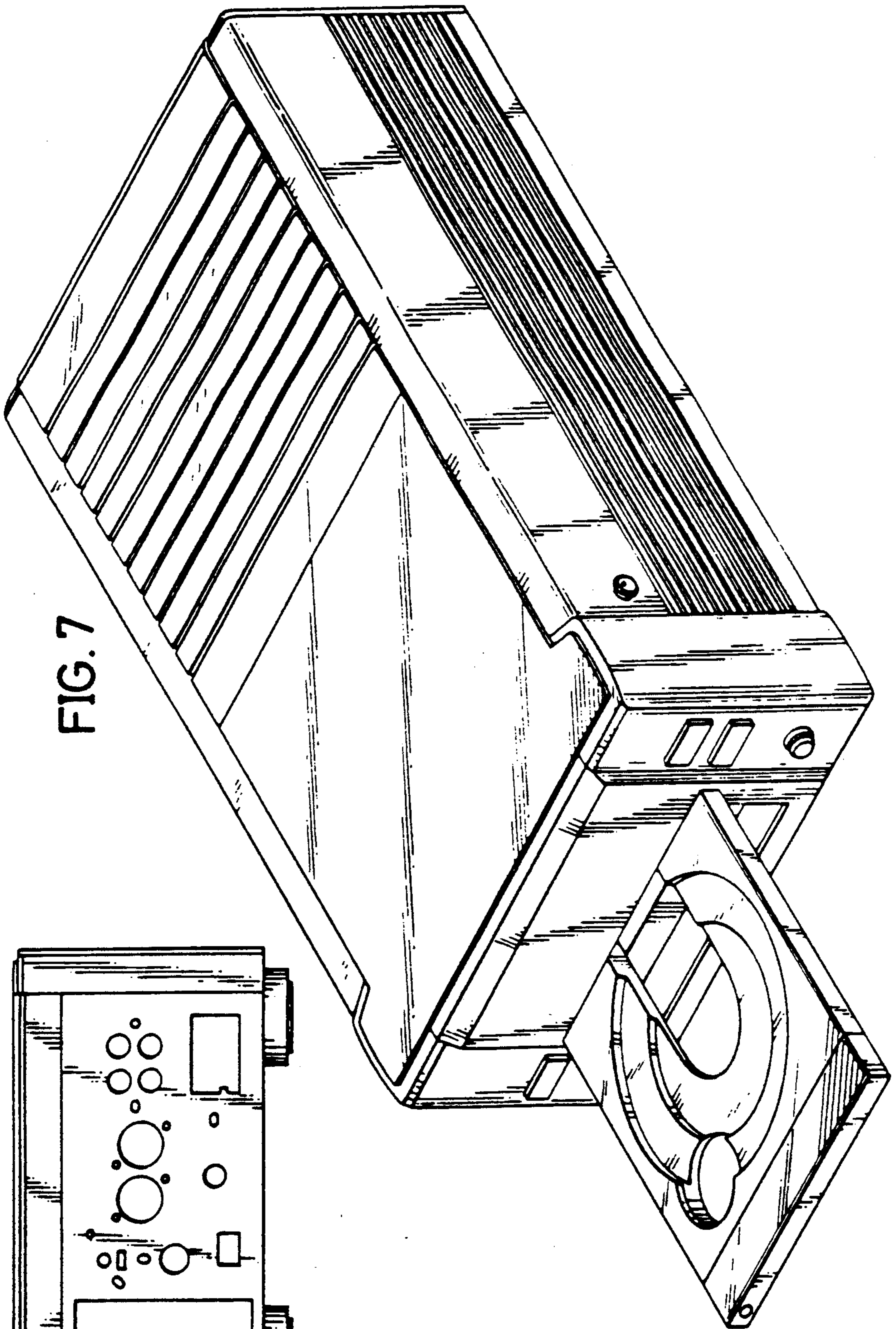

FIG. 7



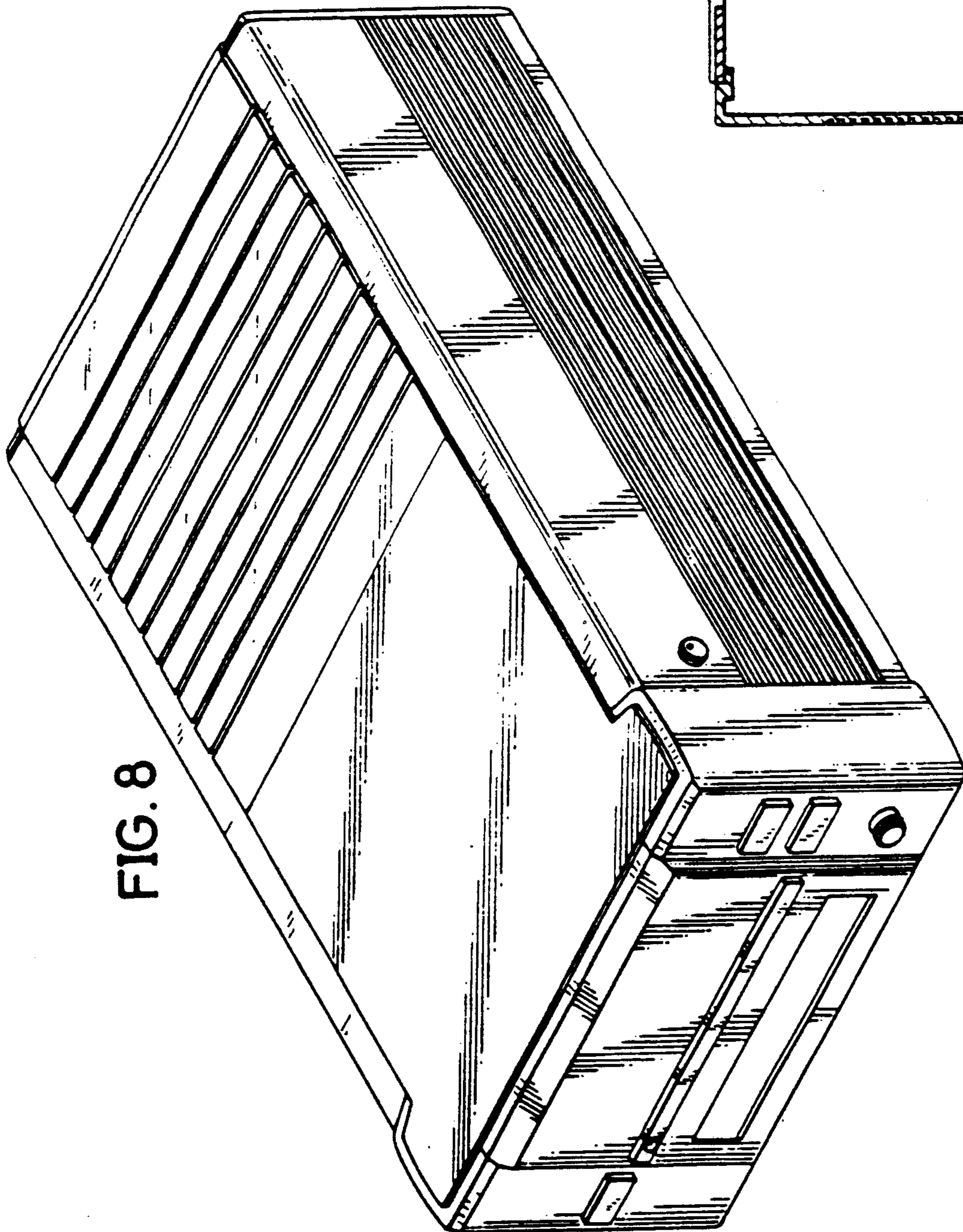

FIG. 8

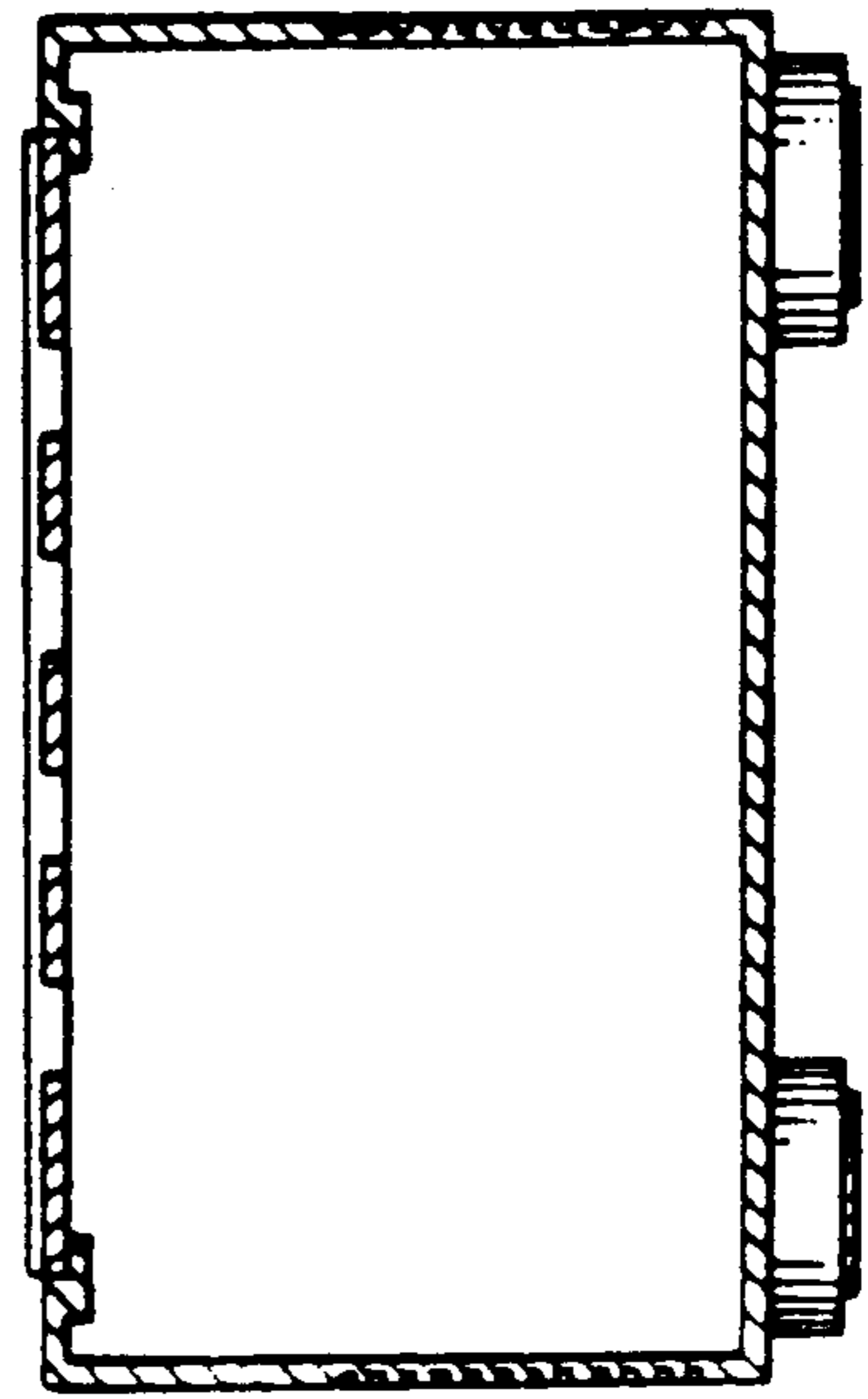

FIG. 9