

[54] VIDEO GAME CONSOLE

[76] Inventor: Wen-Fu Wang, 8F-4, No. 565, Tun-Hwa South Road, Ta-An-District, Taipei, Taiwan

[**] Term: 14 Years

[21] Appl. No.: 252,973

[22] Filed: Oct. 4, 1988

[52] U.S. Cl. D21/48

[58] Field of Search D21/48, 13; 273/85 G, 273/1 GC, 1 E, DIG. 28, 148 B; D13/158, 168; D14/114

[56] References Cited

U.S. PATENT DOCUMENTS

D. 252,926	9/1979	Thompson et al.	D21/13
D. 264,356	5/1982	Nagel	D21/13
D. 265,407	7/1982	Hanzawa	D21/13
4,369,971	1/1983	Chang et al.	273/85 G
4,391,444	7/1983	Bromley	273/85 G X
4,394,018	7/1983	Orbanes et al.	273/1 E X
4,398,717	8/1983	Rosenfield et al.	273/1 GC X

OTHER PUBLICATIONS

Playthings, Feb. 1981, p. 168, right and center of the page, Electronic Boxing.

Playthings, Apr. 1980, p. 48, left & bottom of the page.

Playthings, Feb. 1980, p. 182, Baseball Electronic Game, top & middle of the page.

Primary Examiner—Bernard Ansher

Assistant Examiner—Prabhakar Deshmukh

Attorney, Agent, or Firm—Beveridge, DeGrandi & Weilacher

[57] CLAIM

The ornamental design for a video game console, as shown.

DESCRIPTION

FIG. 1 is a perspective view of a video game console showing my new design;

FIG. 2 is a top plan view thereof;

FIG. 3 is a left side elevation thereof;

FIG. 4 is a right side elevation thereof;

FIG. 5 is a rear elevation thereof; and

FIG. 6 is a bottom plan view thereof.

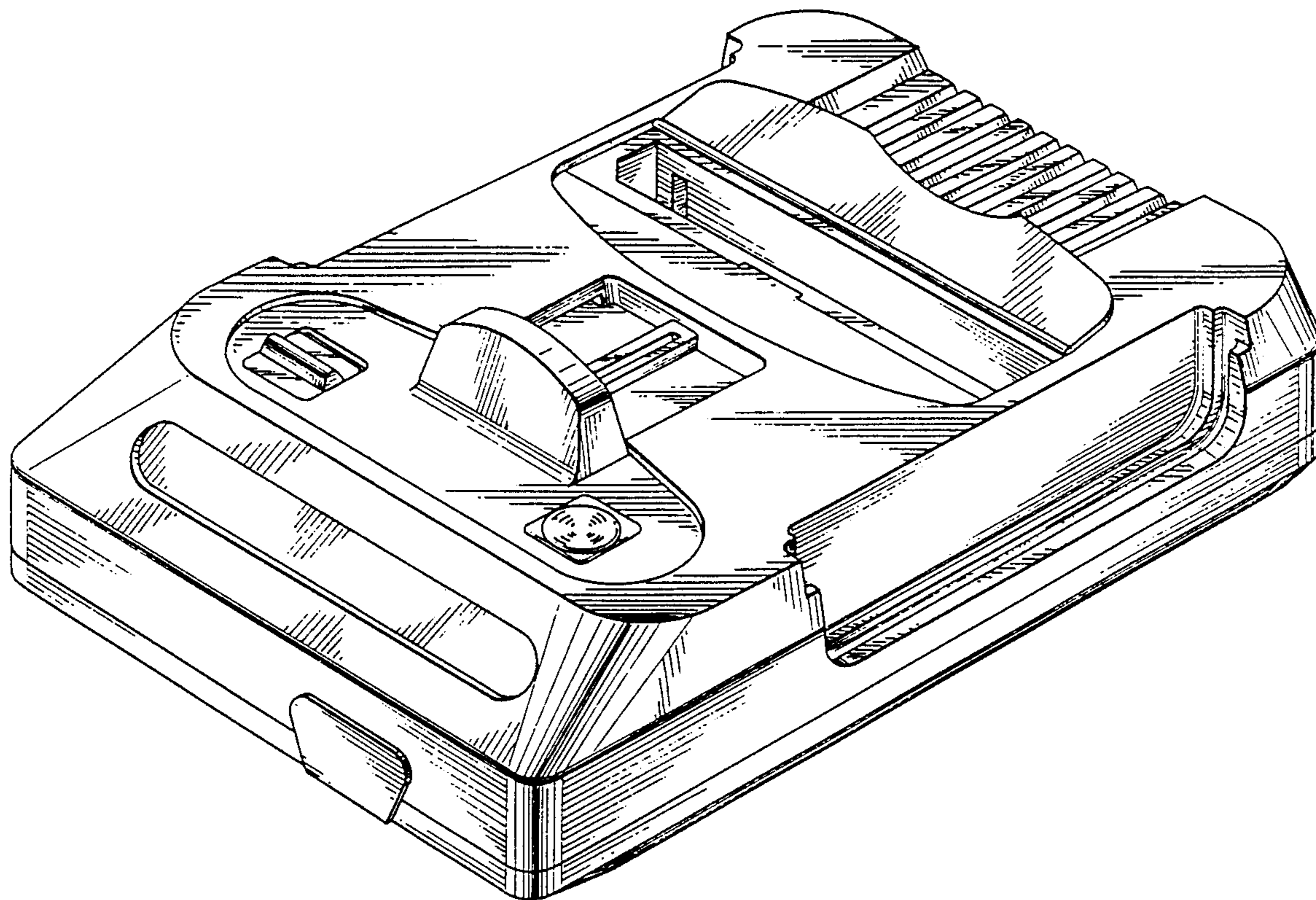

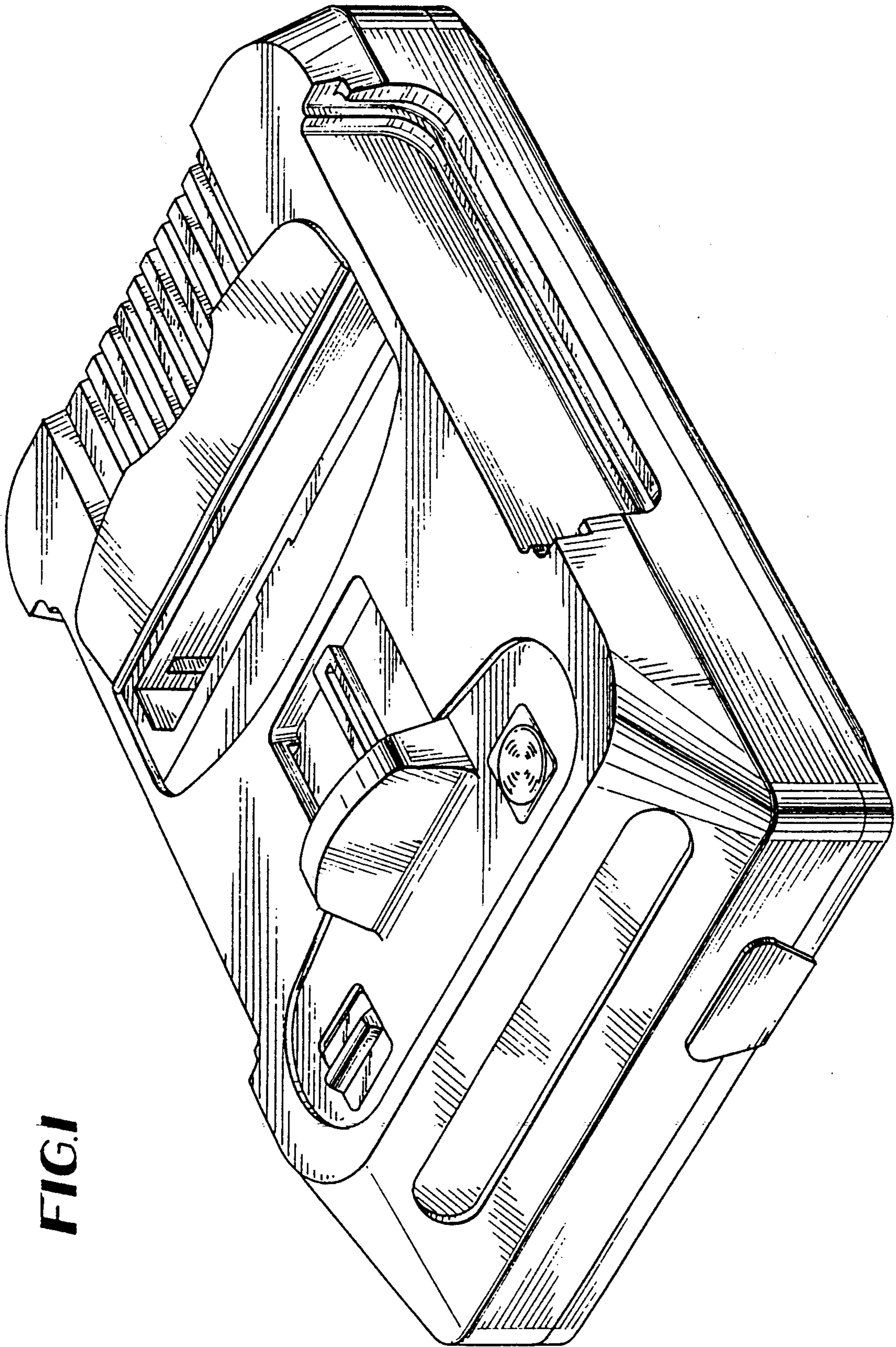

FIG. 1

FIG. 2

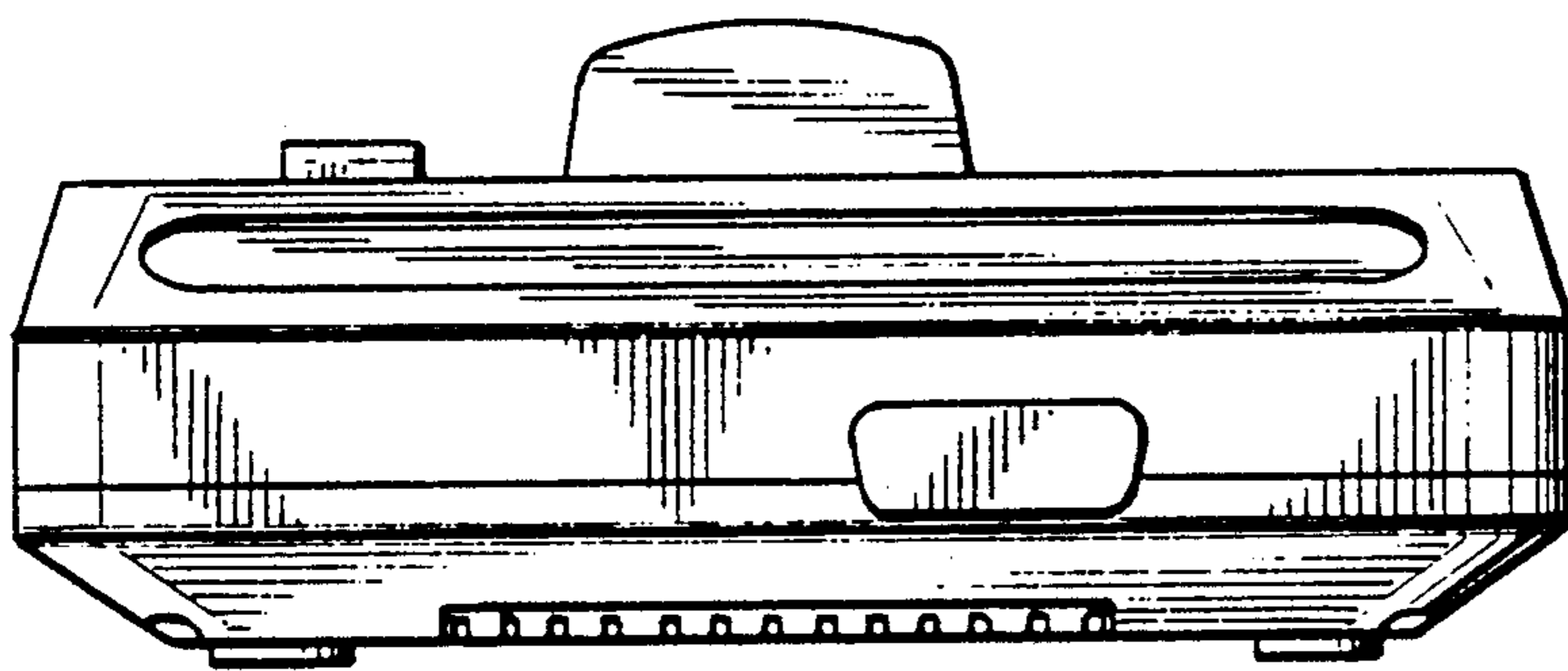
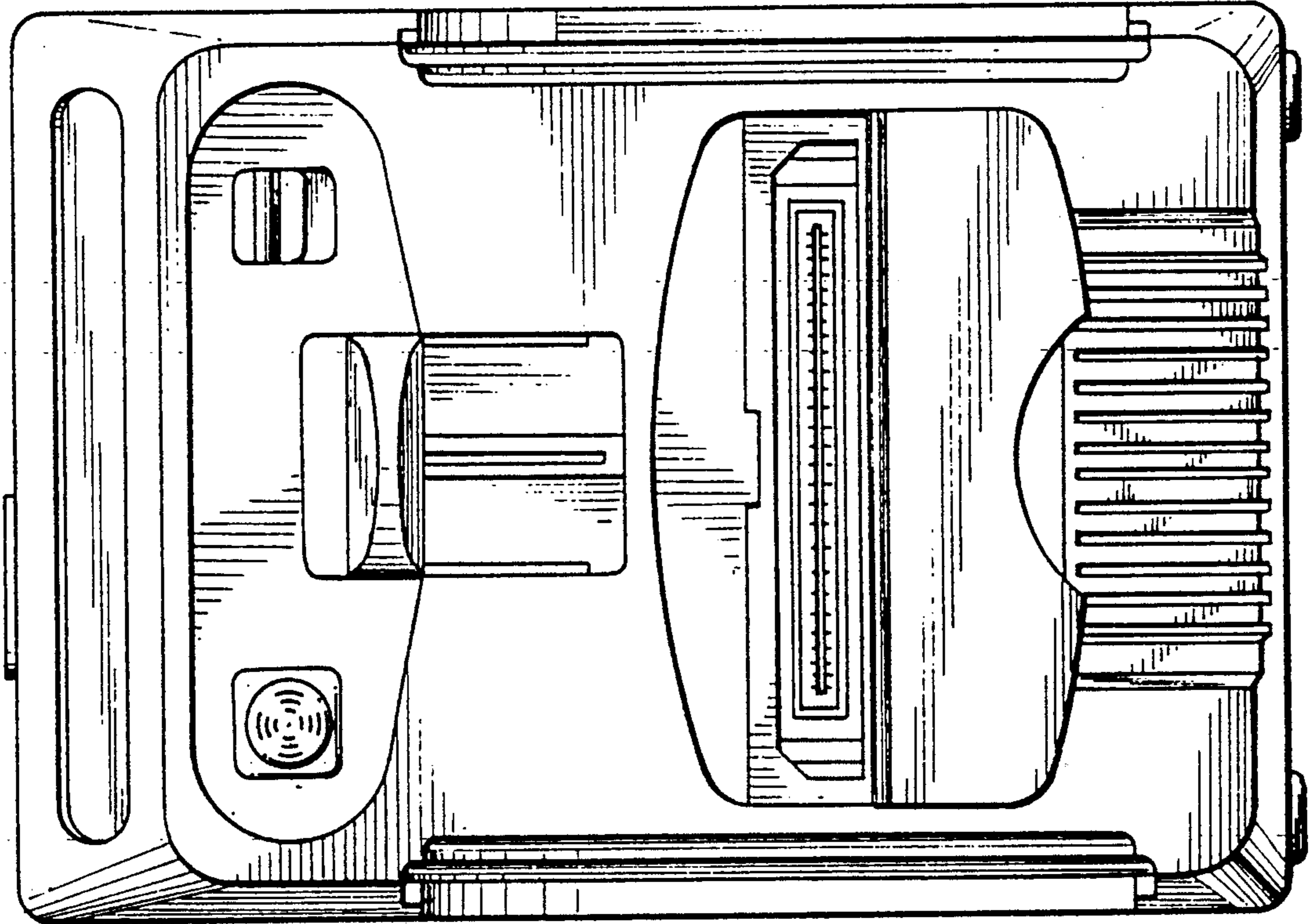

FIG. 3

FIG. 4

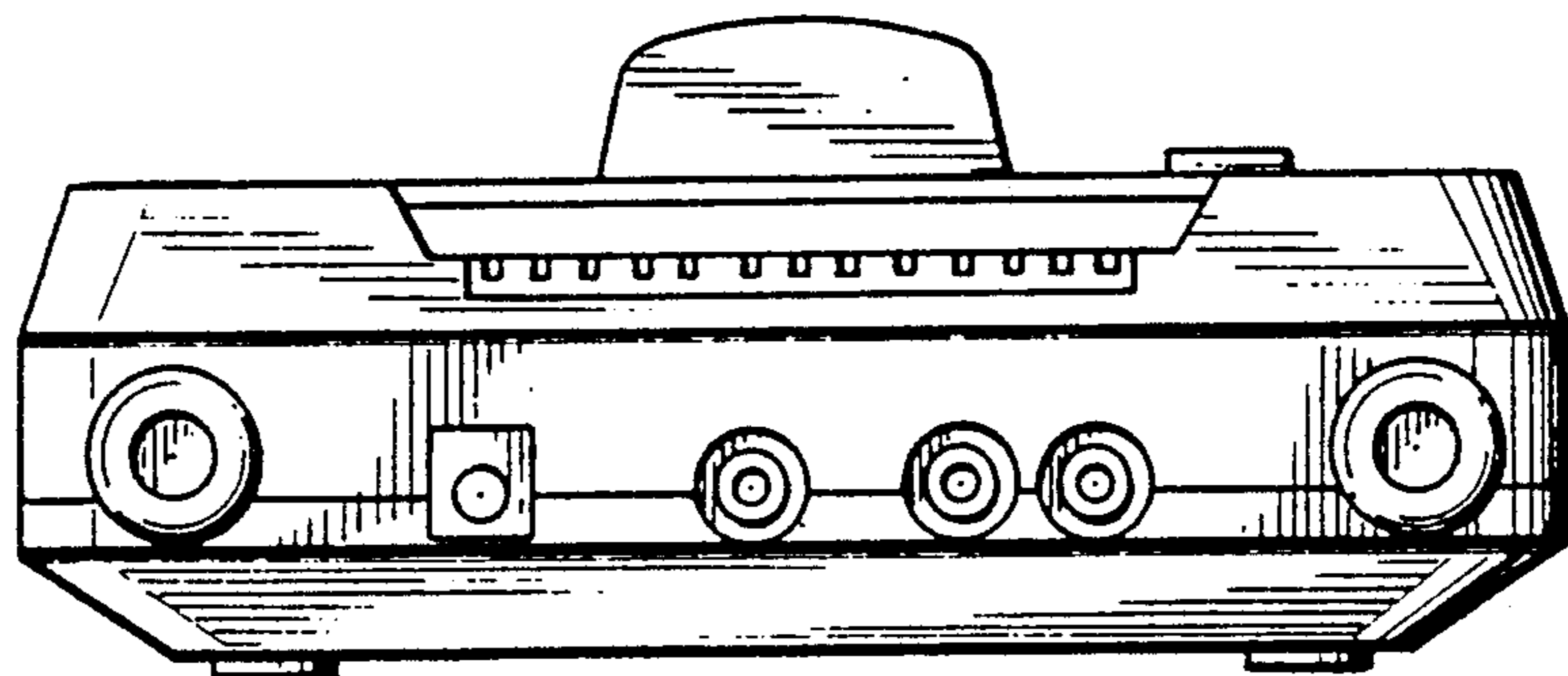

FIG. 5

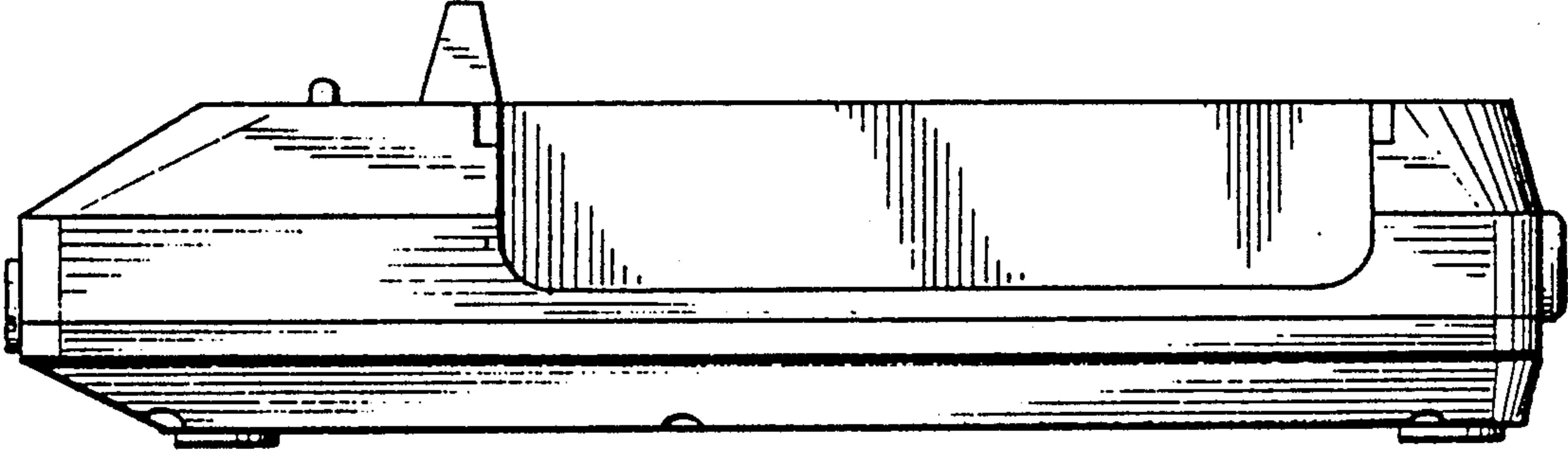

FIG. 6

