

[54] CURRENT PROBE

[75] Inventors: Daniel Arnoux; Axel Arnoux, both of St. Germain en Laye; Claude Genter, Paris, all of France

[73] Assignee: Societe Chauvin Arnoux, Paris, France

[\*\*] Term: 14 Years

[21] Appl. No.: 254,488

[22] Filed: Oct. 6, 1988

[30] Foreign Application Priority Data

Apr. 21, 1988 [FR] France ..... 88 2618

[52] U.S. Cl. .... D10/79

[58] Field of Search ..... D10/75, 78, 79; 324/72.5, 73 R, 117 R, 126, 127 R, 128, 129, 130, 133, 149, 156, 158 P

[56] References Cited

U.S. PATENT DOCUMENTS

- D. 242,991 1/1977 Mckenzie et al. .... D10/79
- D. 249,876 10/1978 Maxwell et al. .... D10/79
- D. 274,892 7/1984 Fallon et al. .... D10/79
- D. 288,301 2/1987 Arnoux et al. .... D10/79
- D. 300,307 3/1989 Arnoux et al. .... D10/79
- 3,840,808 10/1974 Liebermann ..... D10/79 X
- 4,071,824 1/1978 Kernander et al. .... D10/79 X
- 4,283,677 8/1981 Niwa ..... D10/79 X
- 4,518,913 5/1985 Jackson ..... D10/79 X

- 4,825,154 4/1989 Cross et al. .... 324/127
- 4,878,852 11/1989 Bertsch et al. .... 439/103

OTHER PUBLICATIONS

Hioki, 9004~9008, 9005.9006 Clampon Probes, 11/83, p. 20.  
 Electrical and Power Instruments, AC Clamp-Ons, 1986, pp. 24 and 25.  
 Transcatalog, Meters, 1983, pp. 32, 33, 34.  
 A. W. Sperry Instruments Inc., Clamp-On Meters, 7/83, cover and p. 6.  
 Test and Measurement Instrument, Transcat., Clamp-On Power Transducer, 1987, pp. 156-163.  
 Mark-Ned., Clamp-On Meters, 8/81, p. 7.

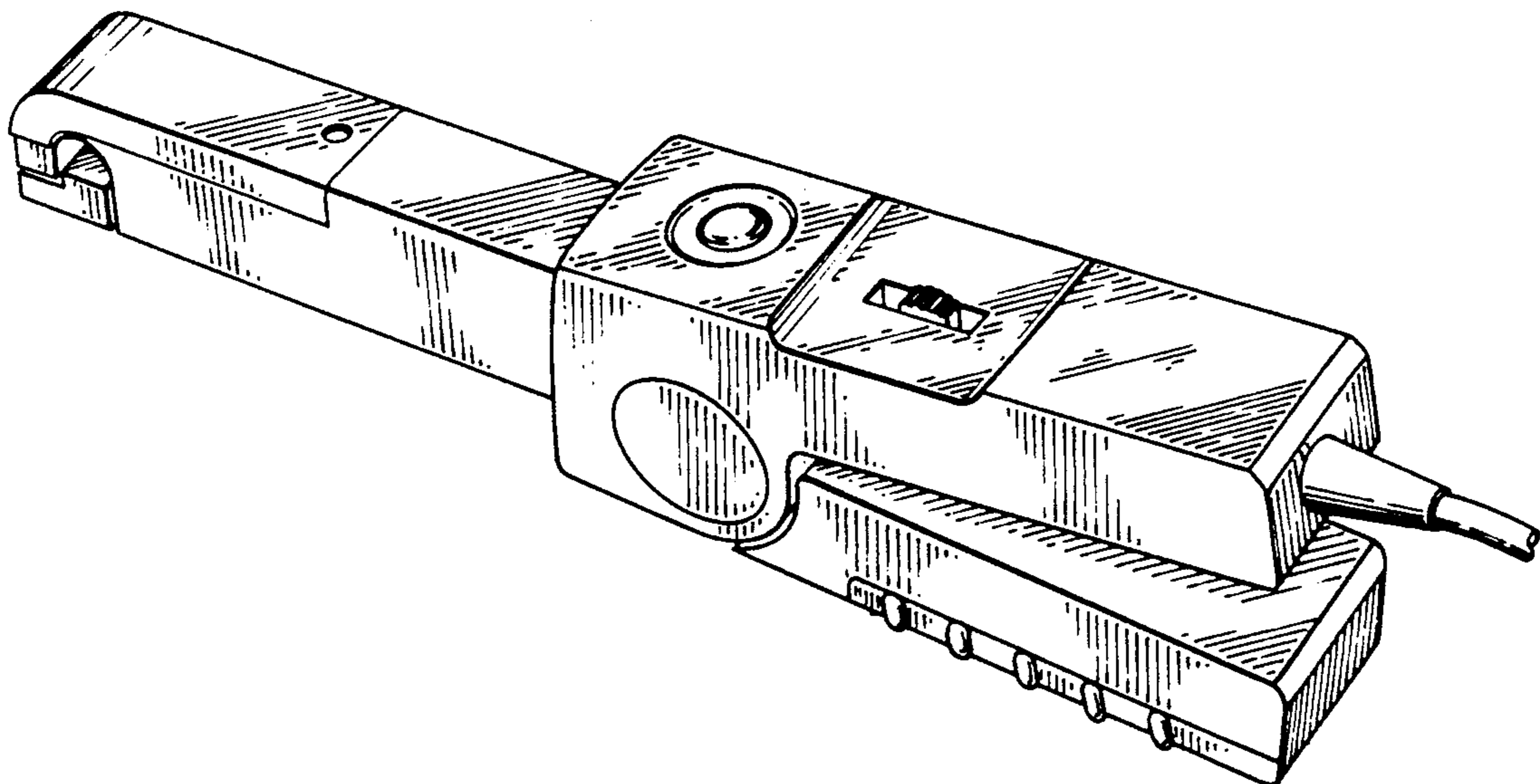
Primary Examiner—Nelson C. Holtje  
 Assistant Examiner—Antoine D. Davis  
 Attorney, Agent, or Firm—Wolf, Greenfield & Sacks

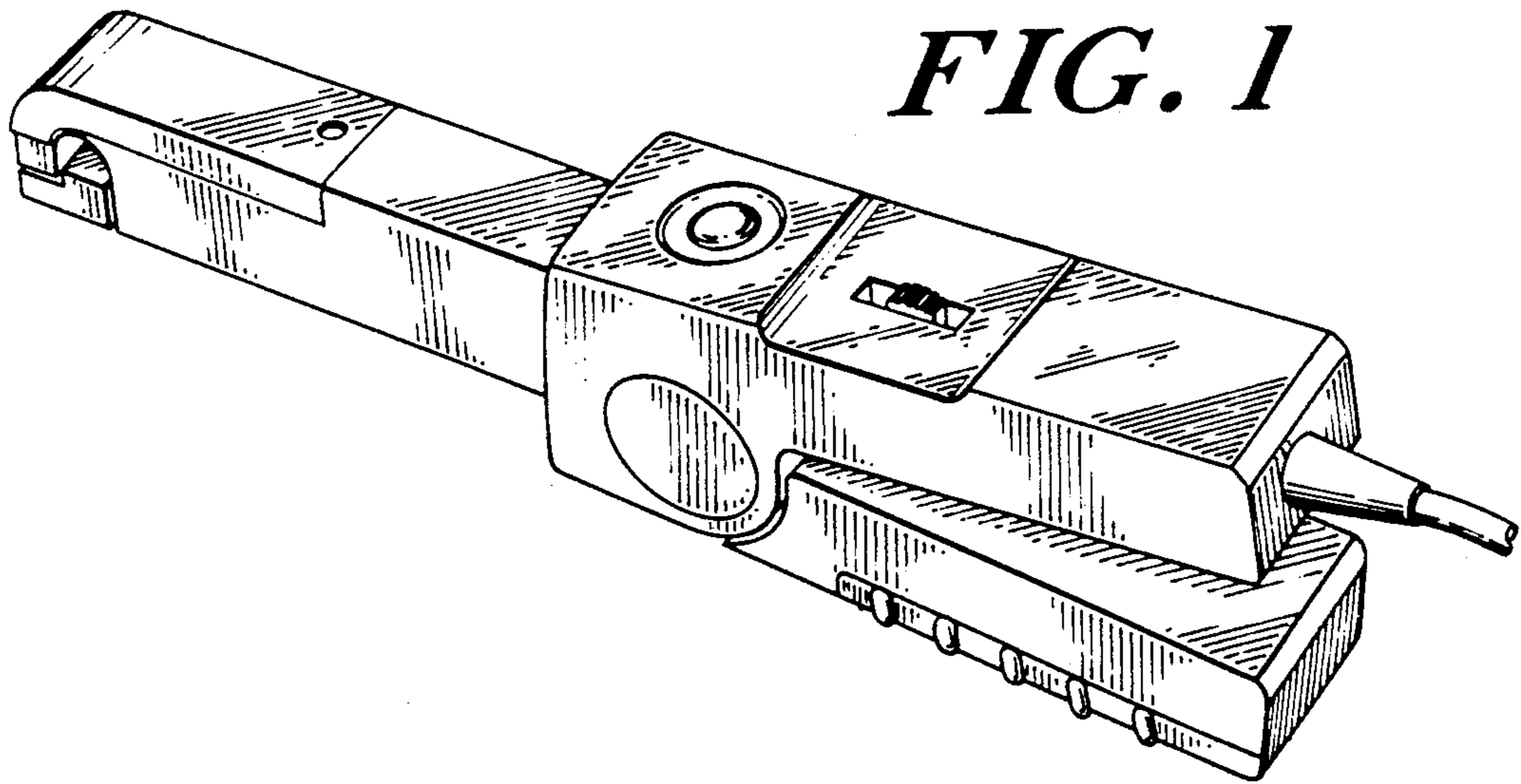
[57] CLAIM

The ornamental design for a current probe, as shown and described.

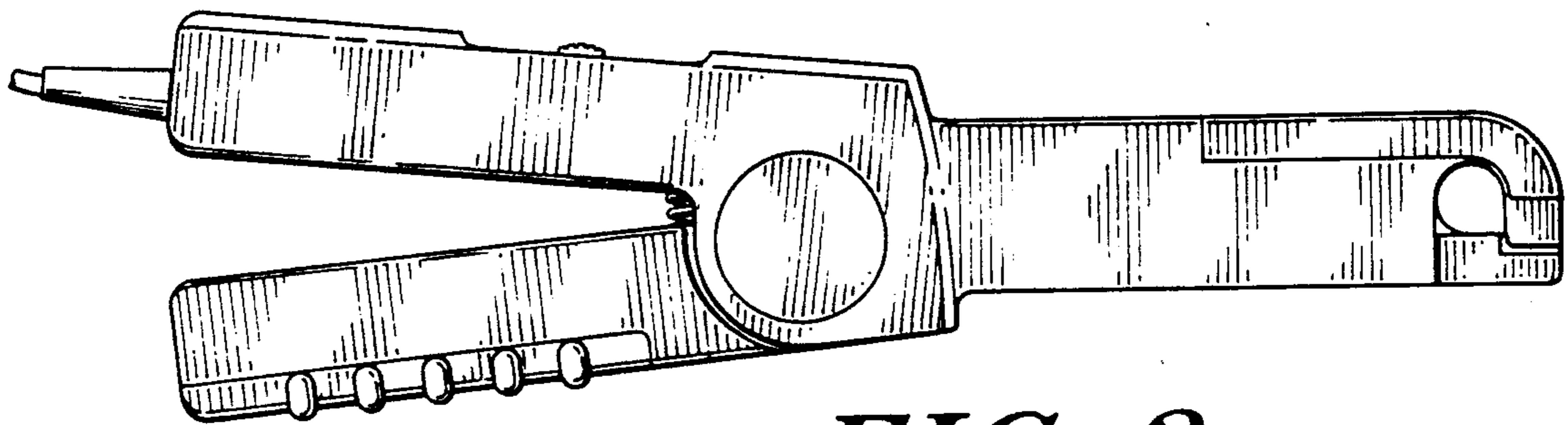
DESCRIPTION

FIG. 1 is a top, rear, and right side perspective view of a current probe showing our new design;  
 FIG. 2 is a left side elevational view;  
 FIG. 3 is a bottom plan view;  
 FIG. 4 is a top plan view;  
 FIG. 5 is a front elevational view; and  
 FIG. 6 is a rear elevational view thereof.

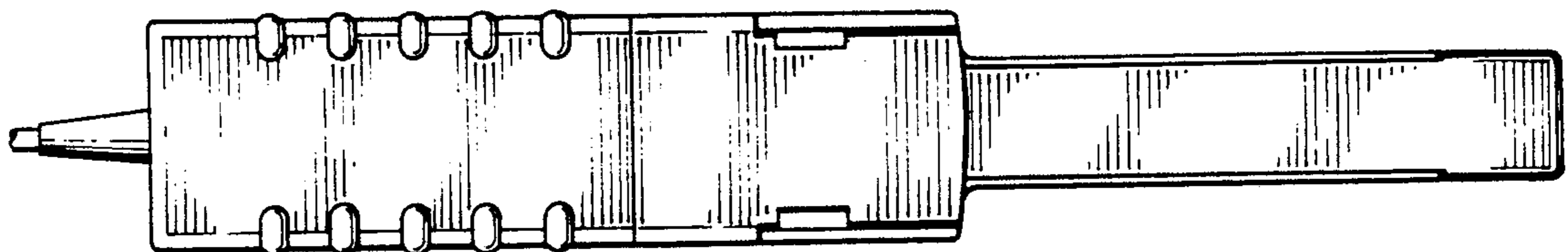




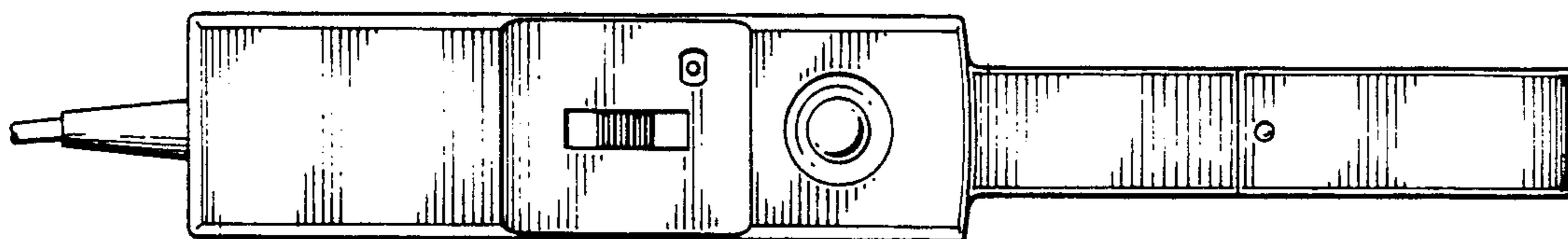
*FIG. 1*



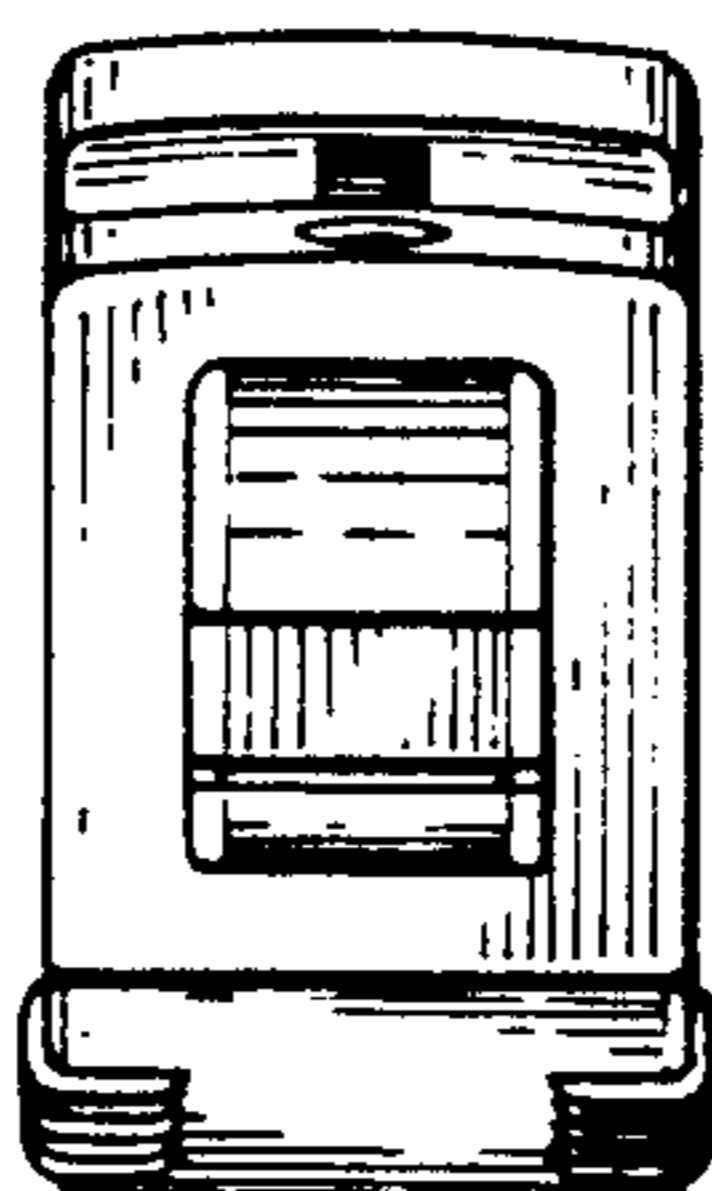
*FIG. 2*



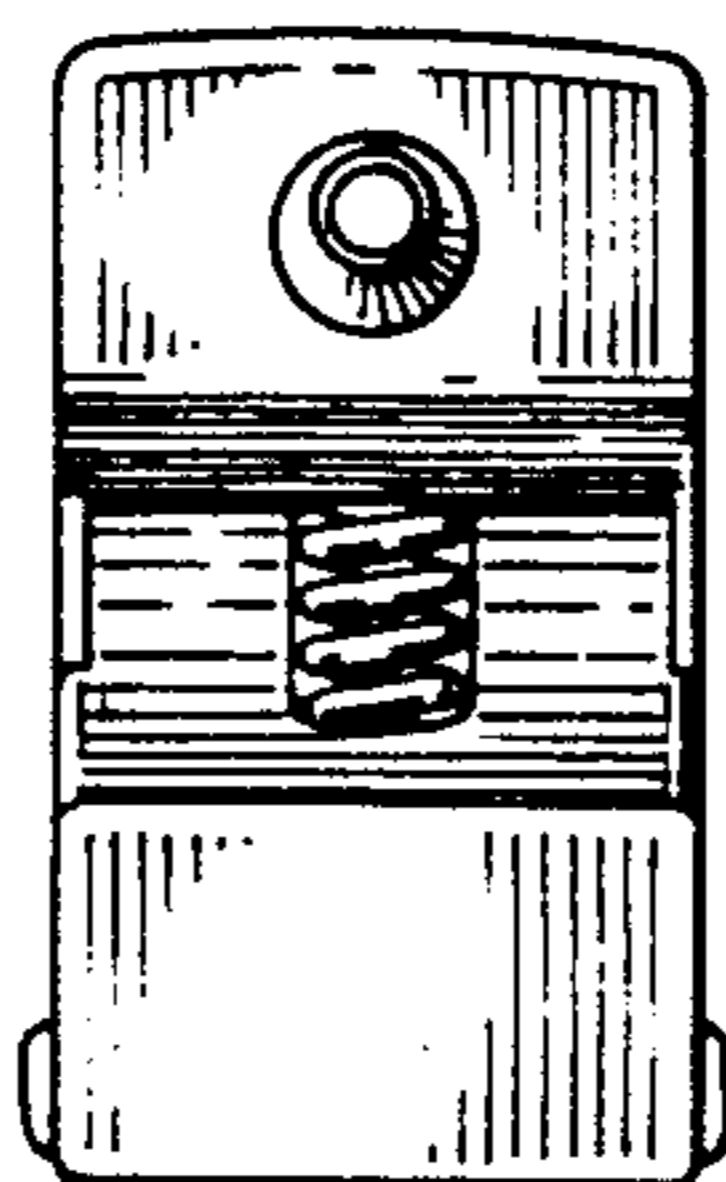
*FIG. 3*



*FIG. 4*



*FIG. 5*



*FIG. 6*