

[54] SNACK PRODUCT

[75] Inventors: Sharon D. Kirkpatrick, Cincinnati; Robert A. Brown, Mason, both of Ohio

[73] Assignee: The Procter & Gamble Company, Cincinnati, Ohio

[**] Term: 14 Years

[21] Appl. No.: 231,552

[22] Filed: Aug. 12, 1988

[52] U.S. Cl. D1/128; D1/127

[58] Field of Search D1/120, 122, 127, 126, D1/128, 129, 130, 199, 106; D6/601; D25/119, 113, 115, 117, 118; D11/40; 426/283, 549, 104, 438, 439, 391, 446, 808, 552, 499, 143, 618, 637, 514, 515

[56] References Cited

U.S. PATENT DOCUMENTS

D. 229,250 11/1973 Citti et al. D1/199
1,327,215 6/1920 Roe D1/106 X

OTHER PUBLICATIONS

Industrial Design, Jan. 1962, p. 39, located in Box AA1-- food pubs.

Thos. Mills & Bro., Inc., 4/1952, p. 43.

Primary Examiner—Wallace R. Burke

Assistant Examiner—Pamela J. Schmidt

Attorney, Agent, or Firm—R. C. Witte; T. H.

O’Flaherty; J. V. Gorman

[57] CLAIM

The ornamental design for a snack product, as shown and described.

DESCRIPTION

FIG. 1 is a front elevational view of a snack product showing our new design, the undisclosed rear being the same;

FIG. 2 is a side elevational view thereof, taken along line 2—2 of FIG. 1, the undisclosed sides as seen perpendicular to the axis of any lobe being the same;

FIG. 3 is a cross-sectional view thereof, taken along line 3—3 of FIG. 3.

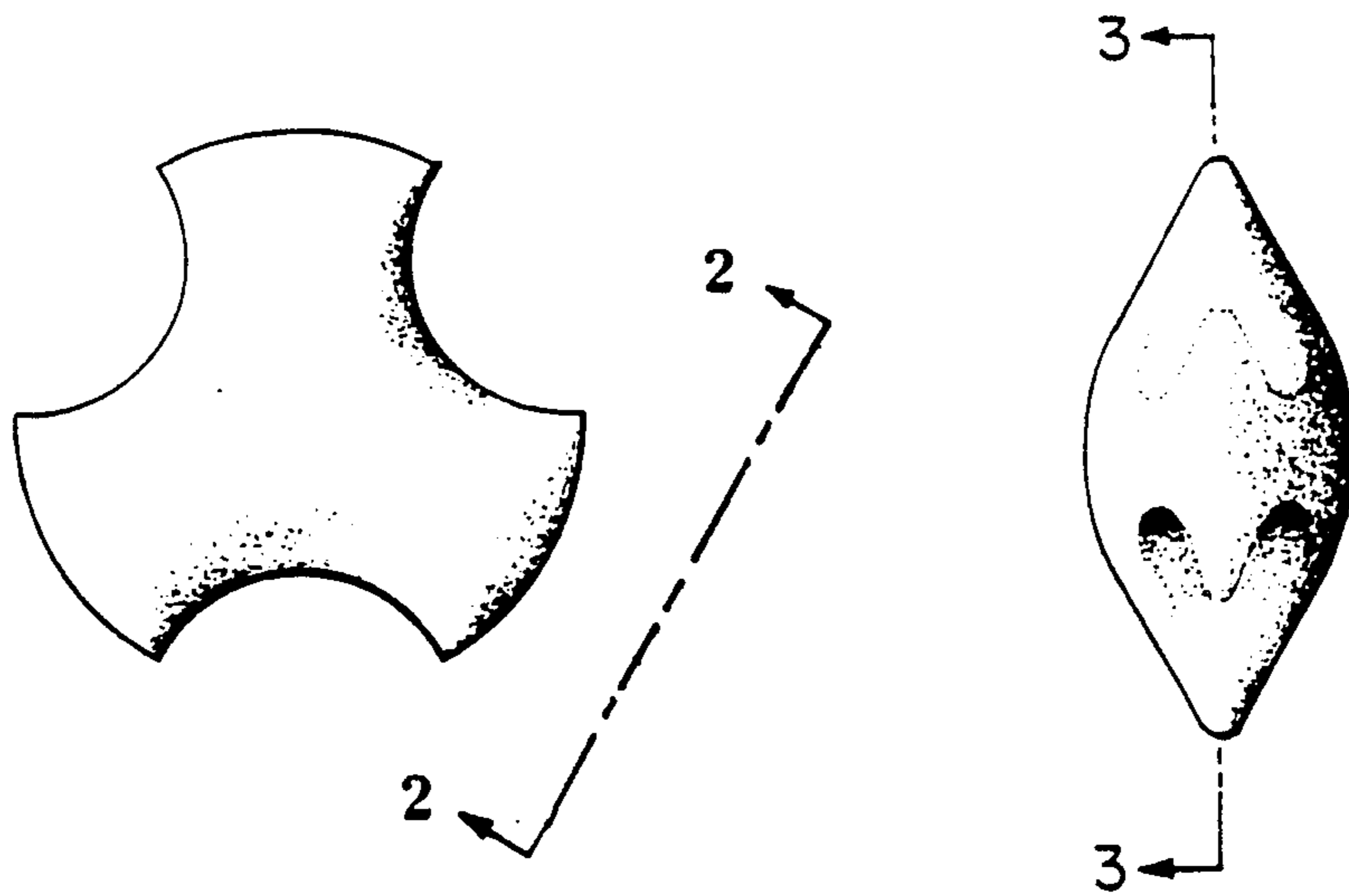

Fig. 1

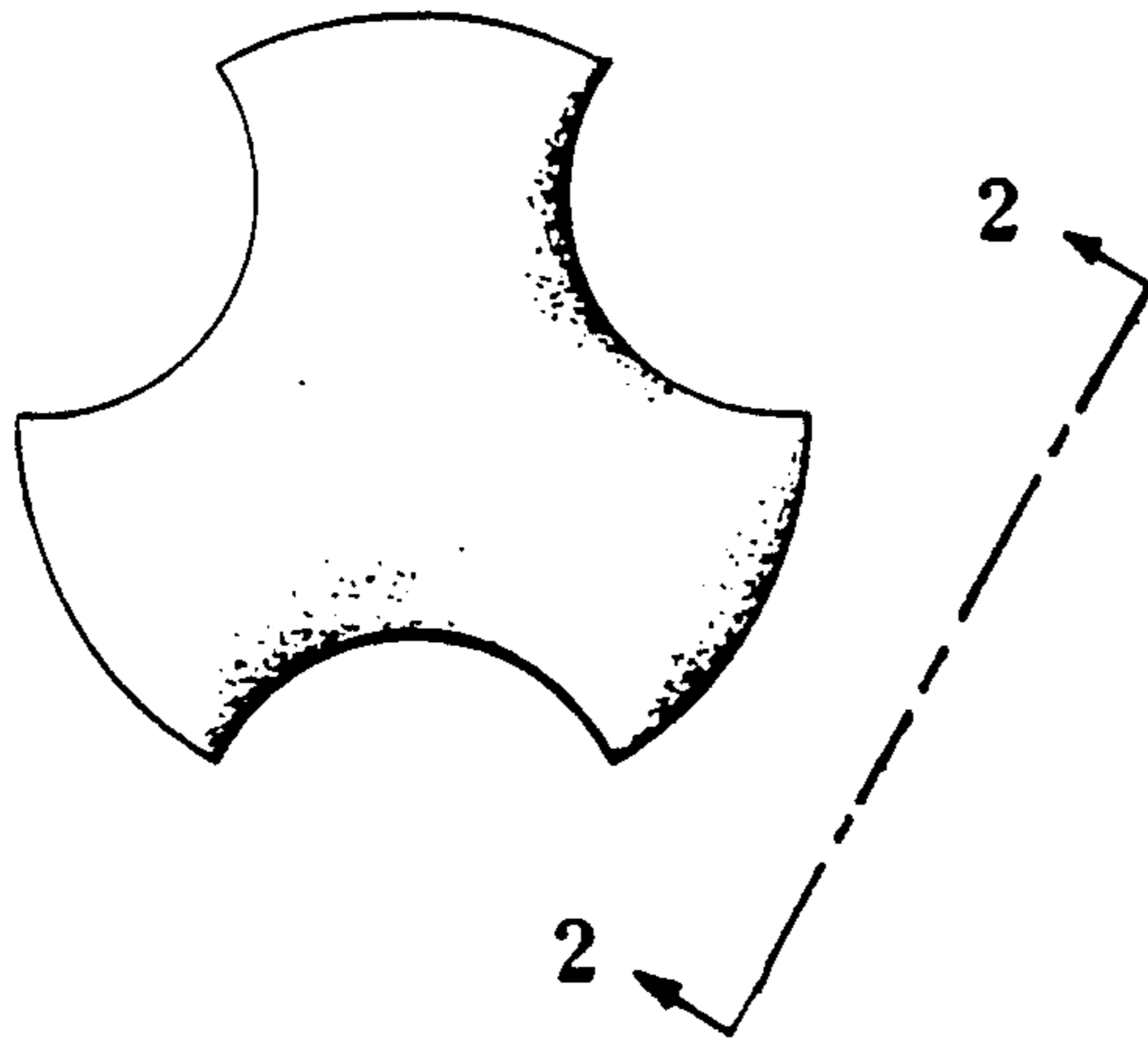

Fig. 2

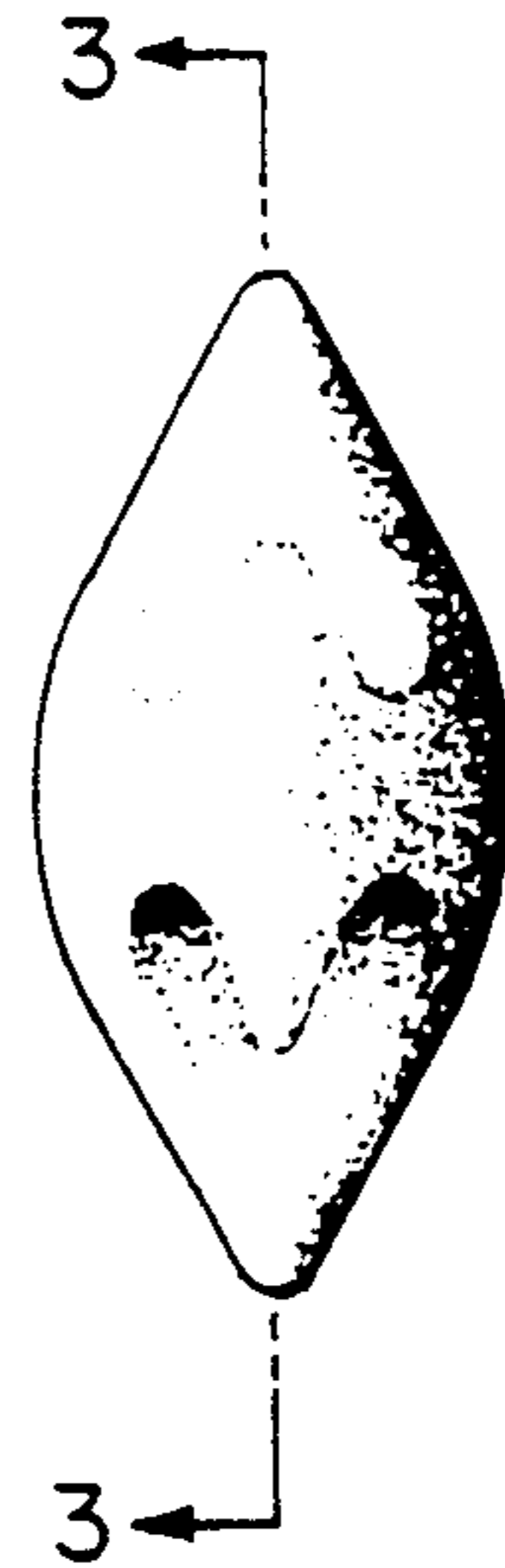

Fig. 3

