

[54] AUTOMOBILE

[75] Inventors: Kazuhiro Ichinose; Naoki Kusano; Hiroyuki Kawase, all of Tokyo, Japan

[73] Assignee: Honda Giken Kogyo Kabushiki Kaisha, Tokyo, Japan

[**] Term: 14 Years

[21] Appl. No.: 289,976

[22] Filed: Dec. 23, 1988

[52] U.S. Cl. D12/92

[58] Field of Search D12/90, 91, 92; 296/185

[56] References Cited PUBLICATIONS

Road & Track, 12/84, p. 38, Panther E M 25 Automobile, bottom of page. Motor Trend, 9/87, p. 18, Ferrari 348 GTB, top of page. Motor Trend, 11/87, pp. 108 & 109, Saab EV-1 Automobile, bottom of page.

Motor Trend, 12/87, p. 17, Diamond-Star Automobile, bottom of page.

Primary Examiner—James M. Gandy Attorney, Agent, or Firm—Lyon & Lyon

[57] CLAIM

The ornamental design for an automobile, as shown and described.

DESCRIPTION

FIG. 1 is a top plan view of an automobile showing our new design; FIG. 2 is a left side elevation view thereof; FIG. 3 is a right side elevation view thereof; FIG. 4 is a front elevation view thereof; FIG. 5 is a rear elevation view thereof; FIG. 6 is a top plan view of another embodiment of an automobile showing our new design; FIG. 7 is a left side elevation view of the automobile of FIG. 6; FIG. 8 is a right side elevation view of the automobile of FIG. 6; FIG. 9 is a front elevation view of the automobile of FIG. 6; and FIG. 10 is a rear elevation view of the automobile of FIG. 6.

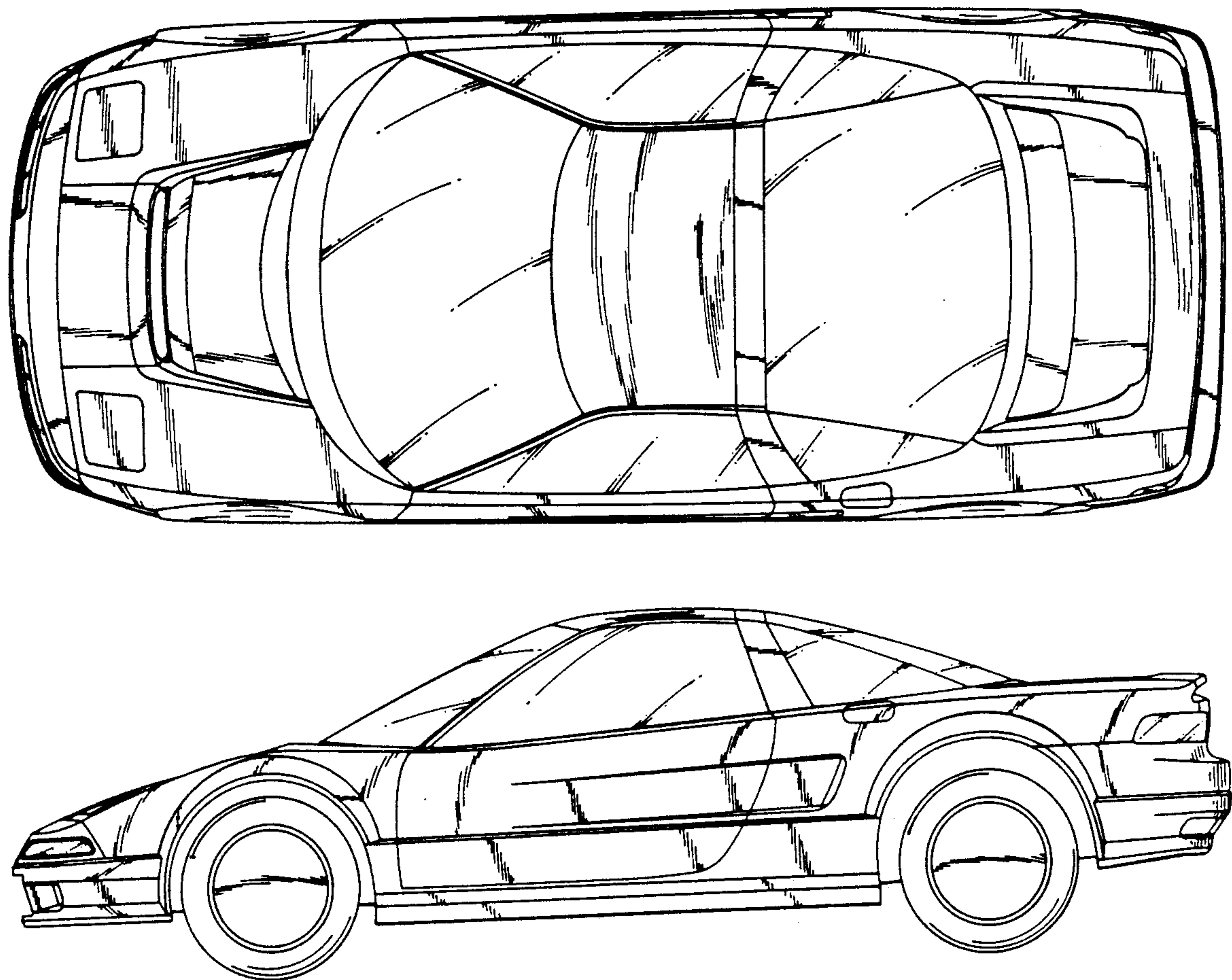

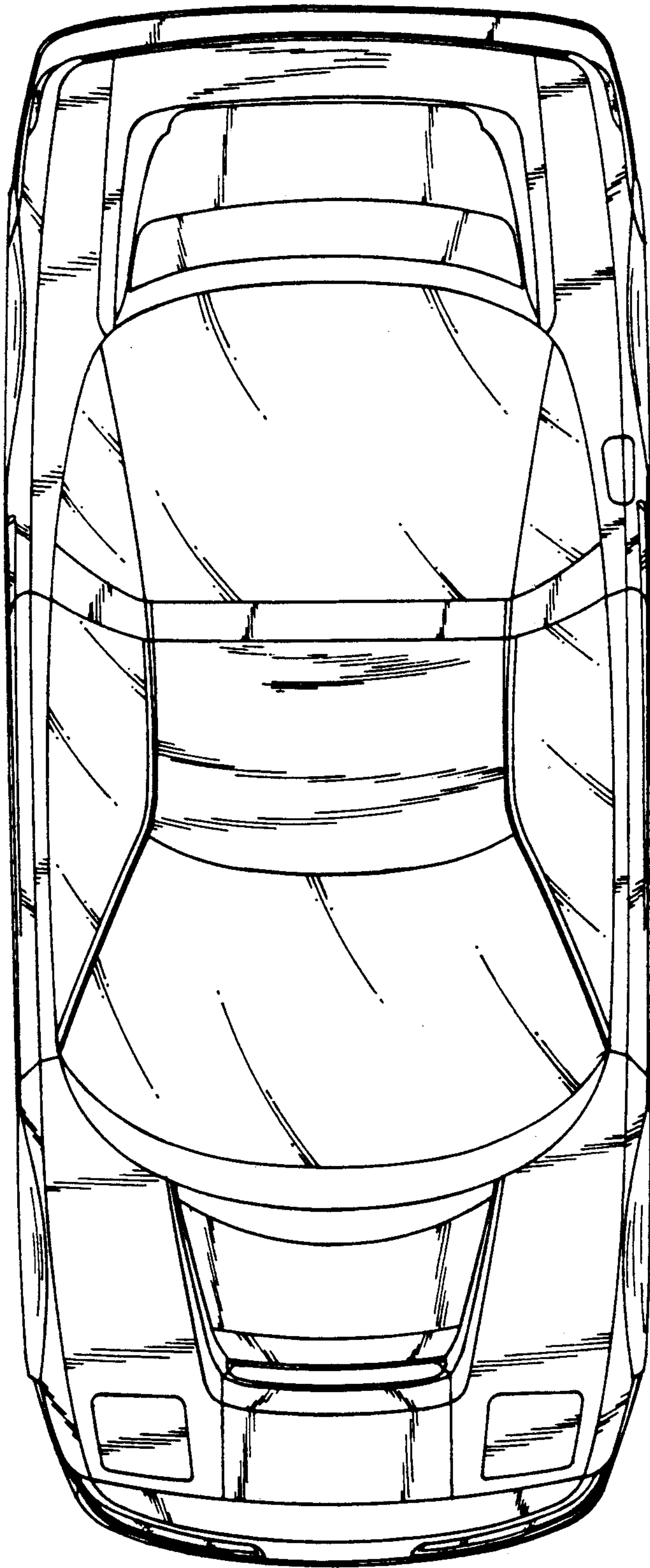

fig. 1.

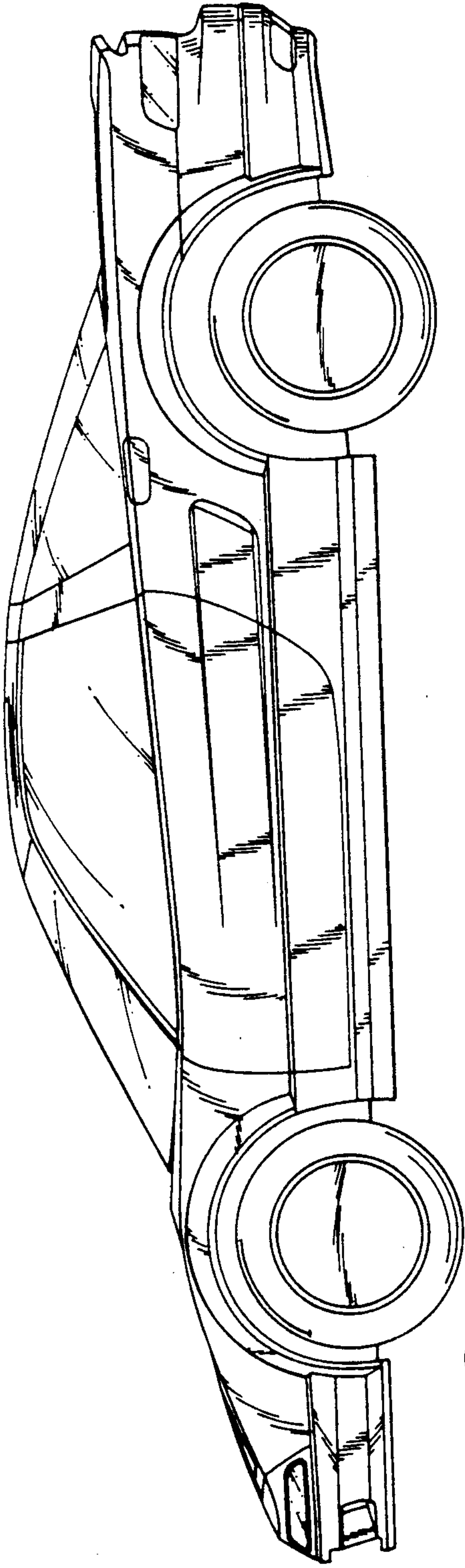
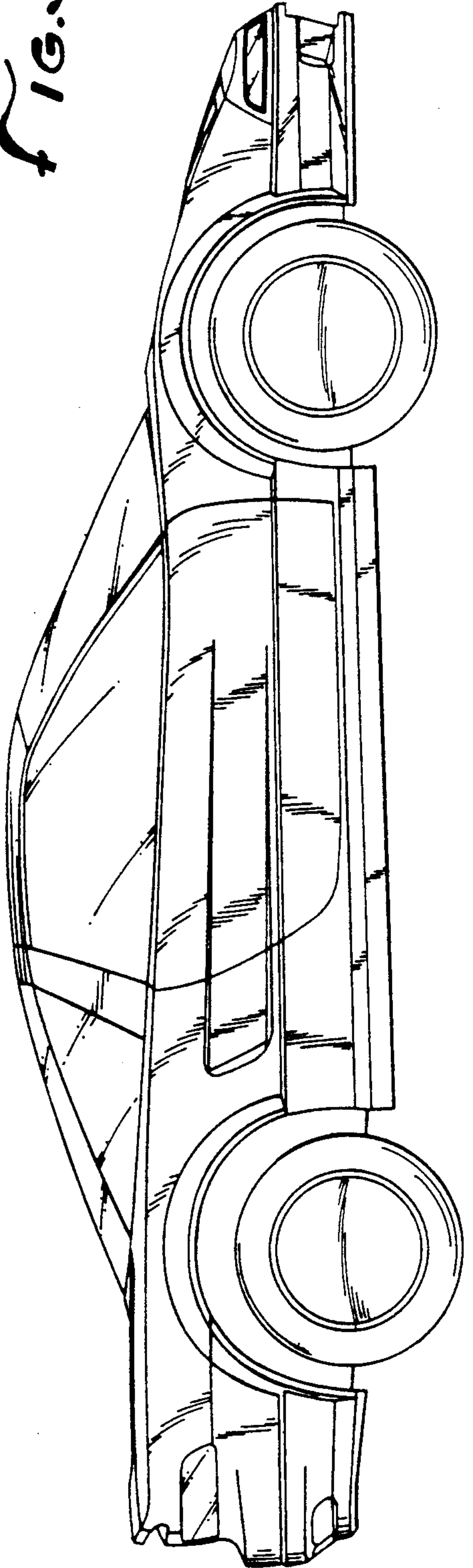

FIG. 2.

FIG. 3.



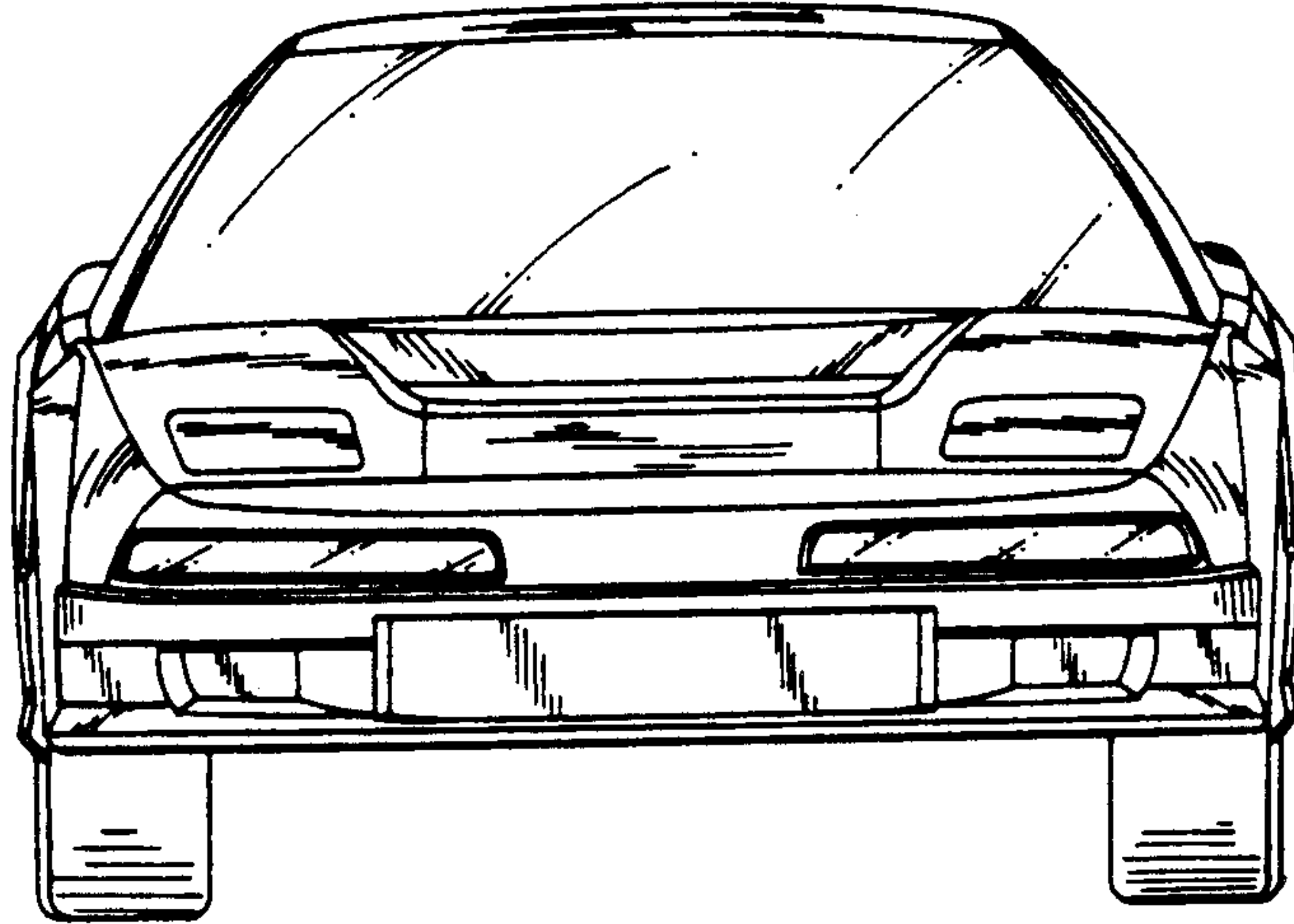

FIG. 4.

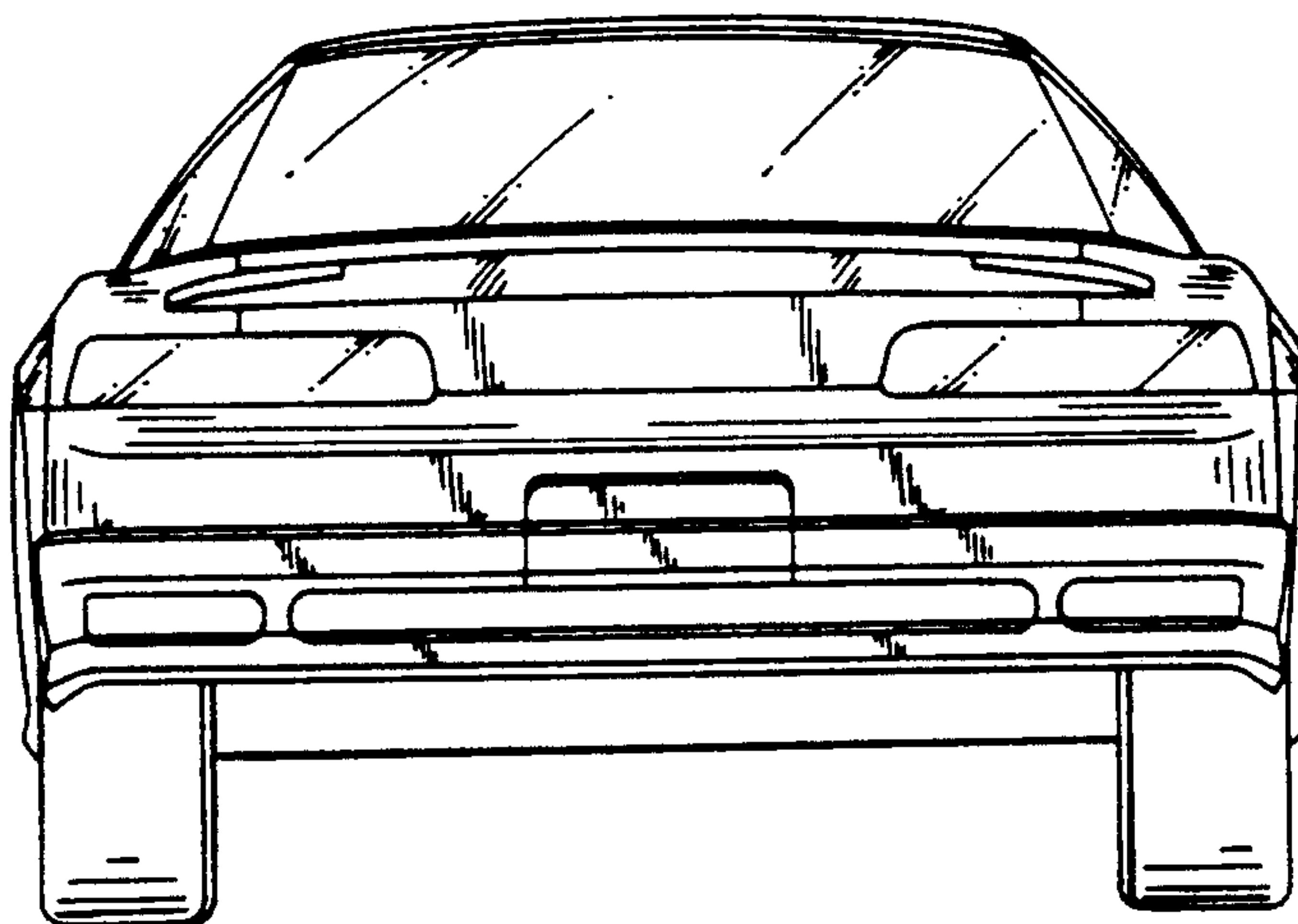

FIG. 5.

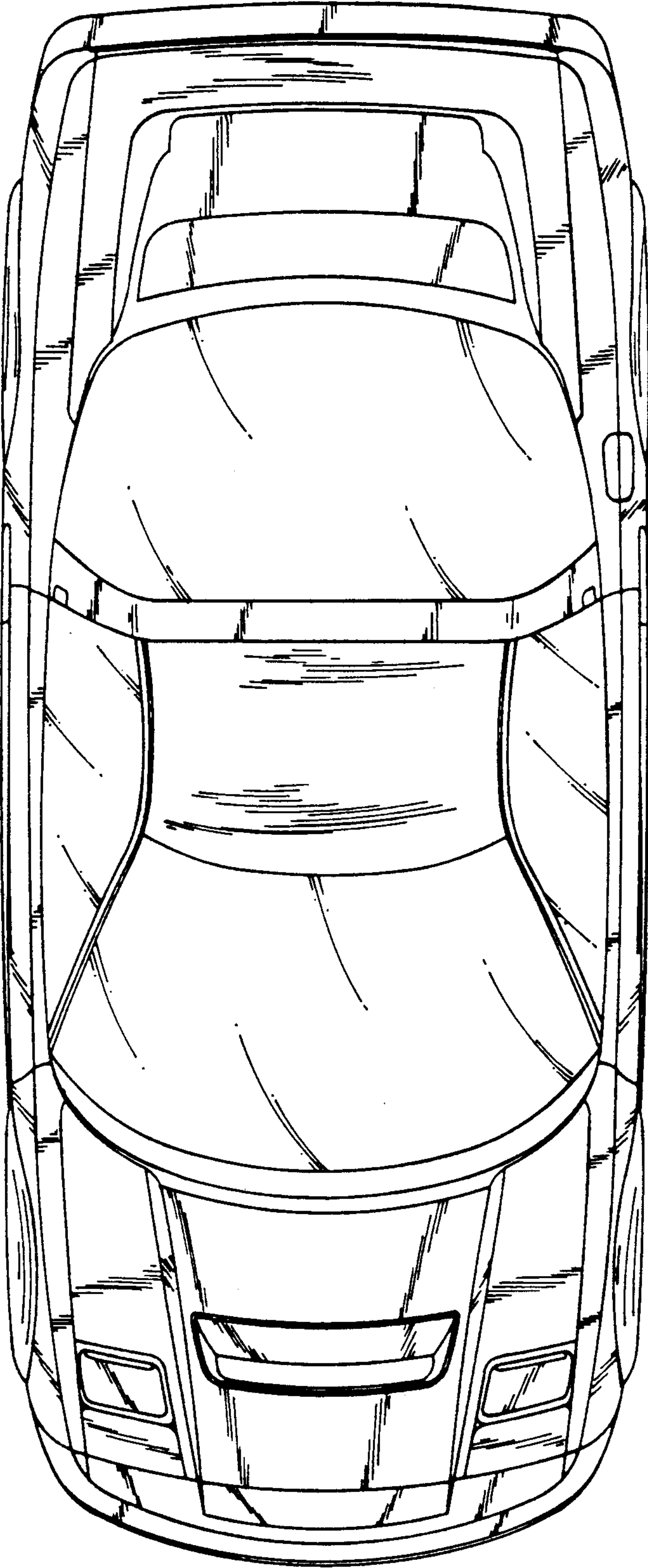

FIG. 6.

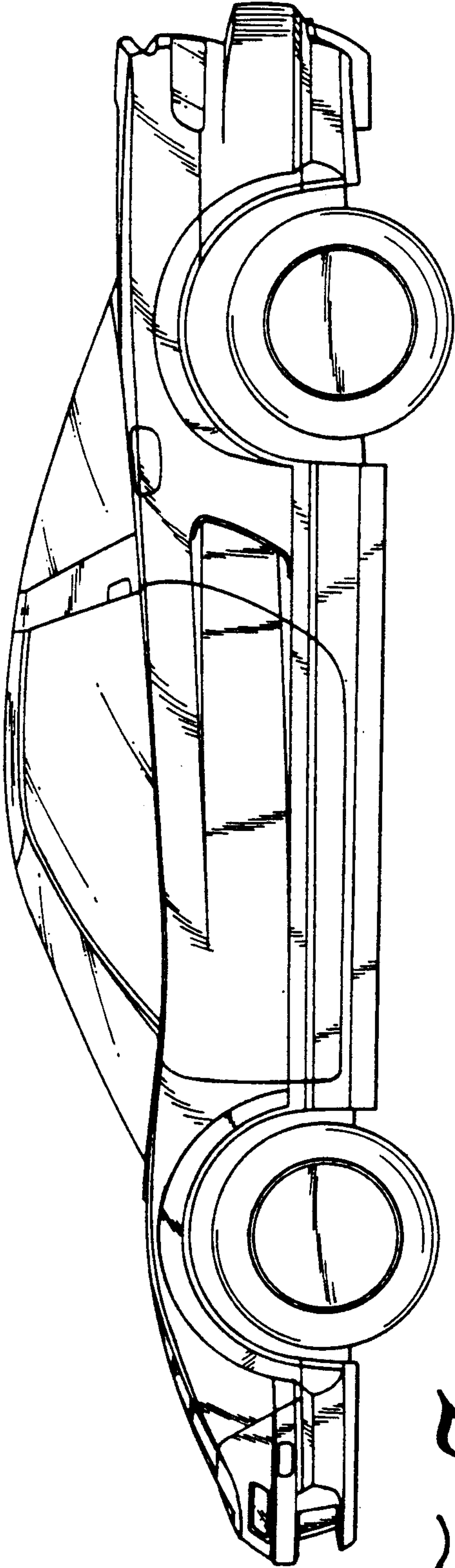
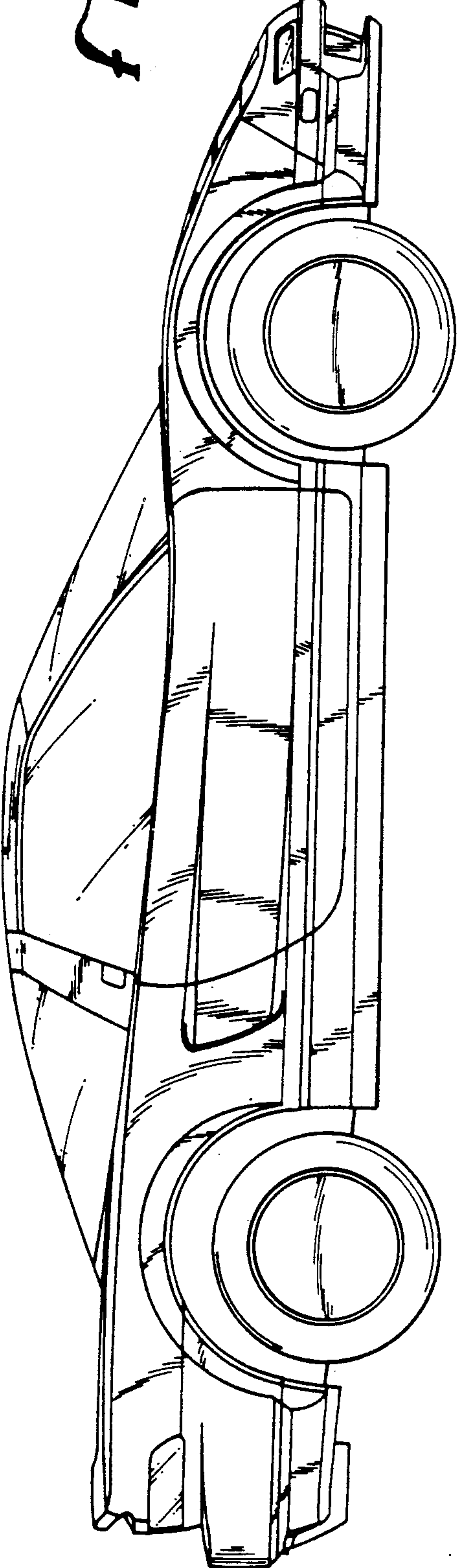

FIG. 7.

FIG. 8.



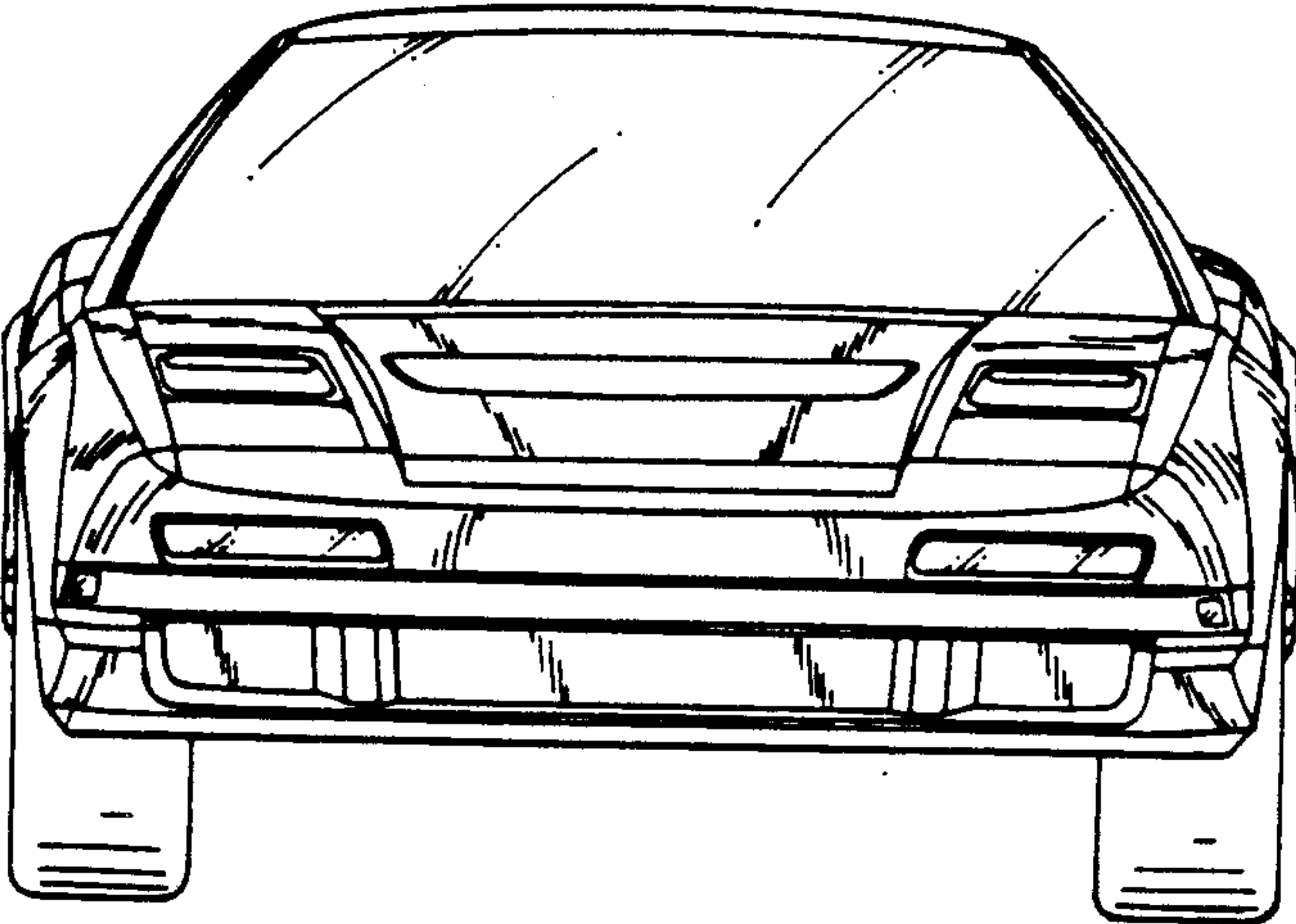

FIG. 9.

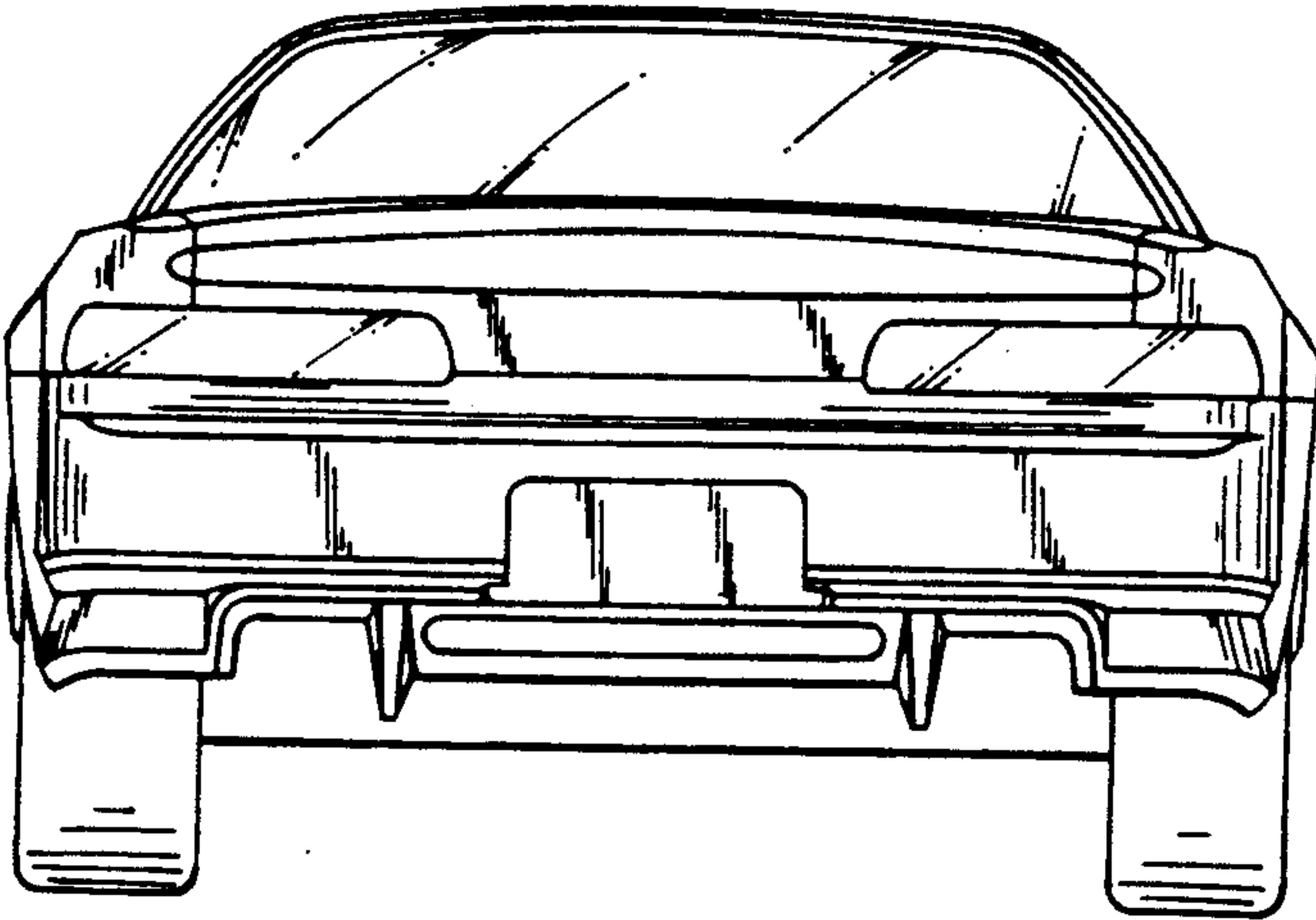

FIG. 10.