

[54] ELECTRIC FAN FOR AUTOMOBILE OR SIMILAR ARTICLE

[76] Inventor: Chinfu Chiang, No. 182, Sec. 1, Chin-Hwa Rd., Tainan, Taiwan

[**] Term: 14 Years

[21] Appl. No.: 379,168

[22] Filed: Jul. 13, 1989

[30] Foreign Application Priority Data

Nov. 28, 1988 [TW] Taiwan 77306875

[52] U.S. Cl. D23/324; D23/382

[58] Field of Search D23/324, 382, 370, 377, D23/379, 336, 247 R; 416/247 R, 246; 415/121.2; 219/202, 366, 369, 370, 371, 373; 248/126, 176, 183

[56] References Cited

U.S. PATENT DOCUMENTS

D. 104,119 4/1937 Schwarz D23/382

D. 112,847 1/1939 Roffy D23/377
D. 129,488 9/1941 Norris D23/382
D. 197,194 12/1963 Dahlberg D23/370
1,907,032 5/1933 Askin D23/324
3,402,882 9/1968 Militello 415/121.2

Primary Examiner—James M. Gandy
Assistant Examiner—Lisa Lichtenstein
Attorney, Agent, or Firm—Ashen Martin Seldon Lippman & Scillieri

[57] CLAIM

The ornamental design for an electric fan for automobile or similar article, as shown.

DESCRIPTION

FIG. 1 is a perspective view of electric fan for automobile or similar article showing my new design; FIG. 2 is a front elevational view thereof; FIG. 3 is a rear elevational view thereof; FIG. 4 is a left side elevational view thereof; FIG. 5 is a right side elevational view thereof; FIG. 6 is a top plan view thereof; and FIG. 7 is a bottom plan view thereof.

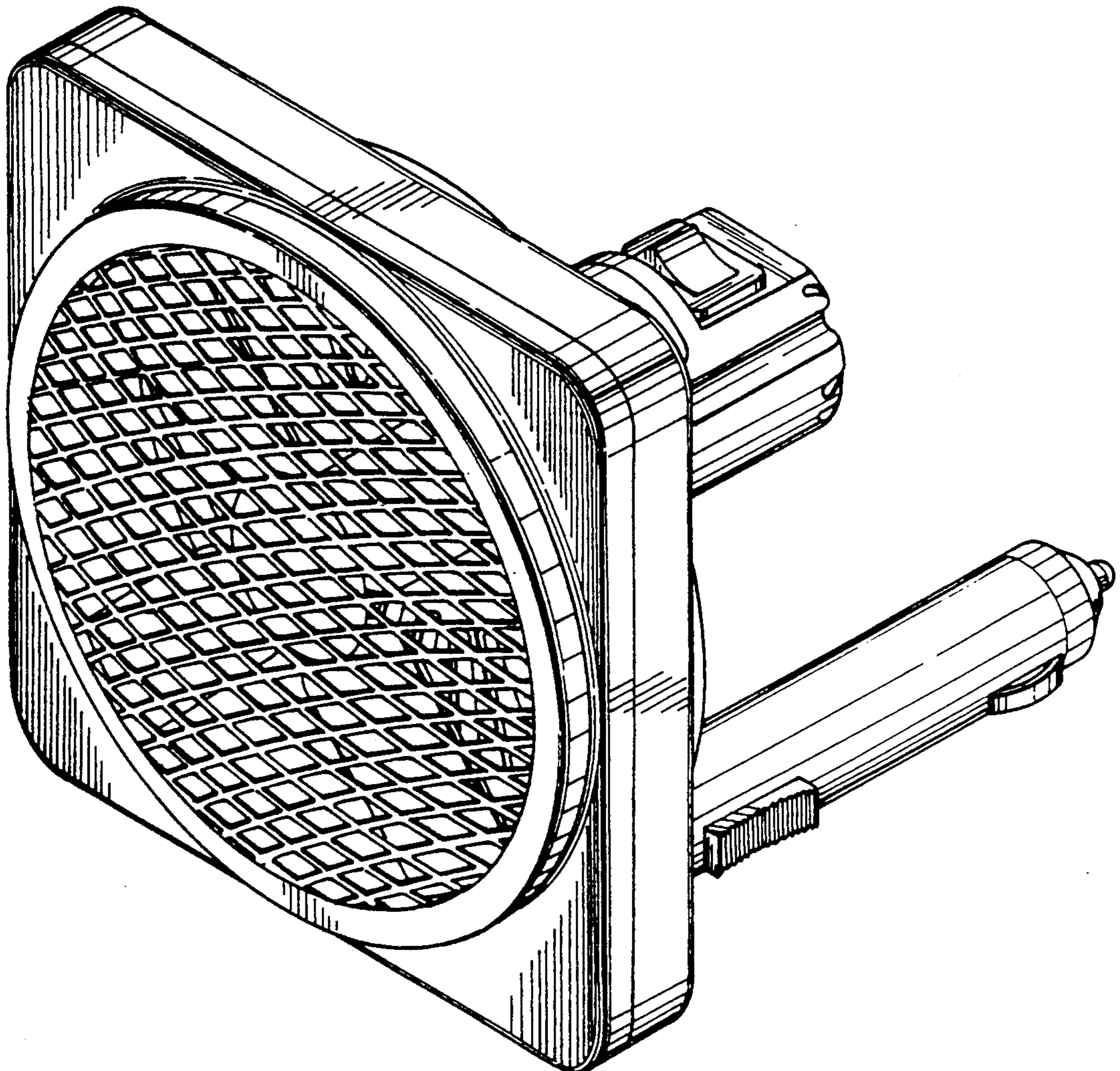

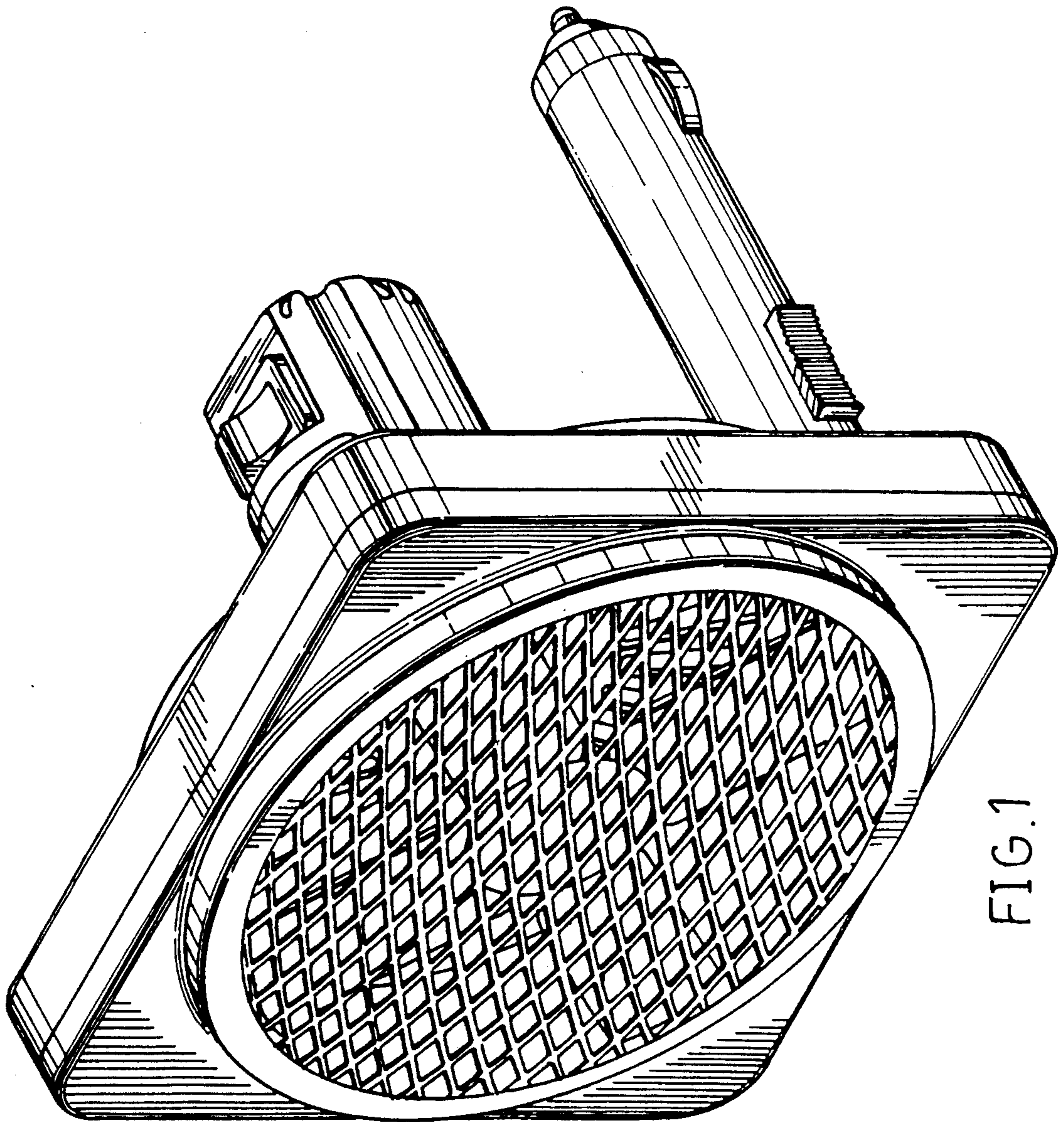

FIG. 1

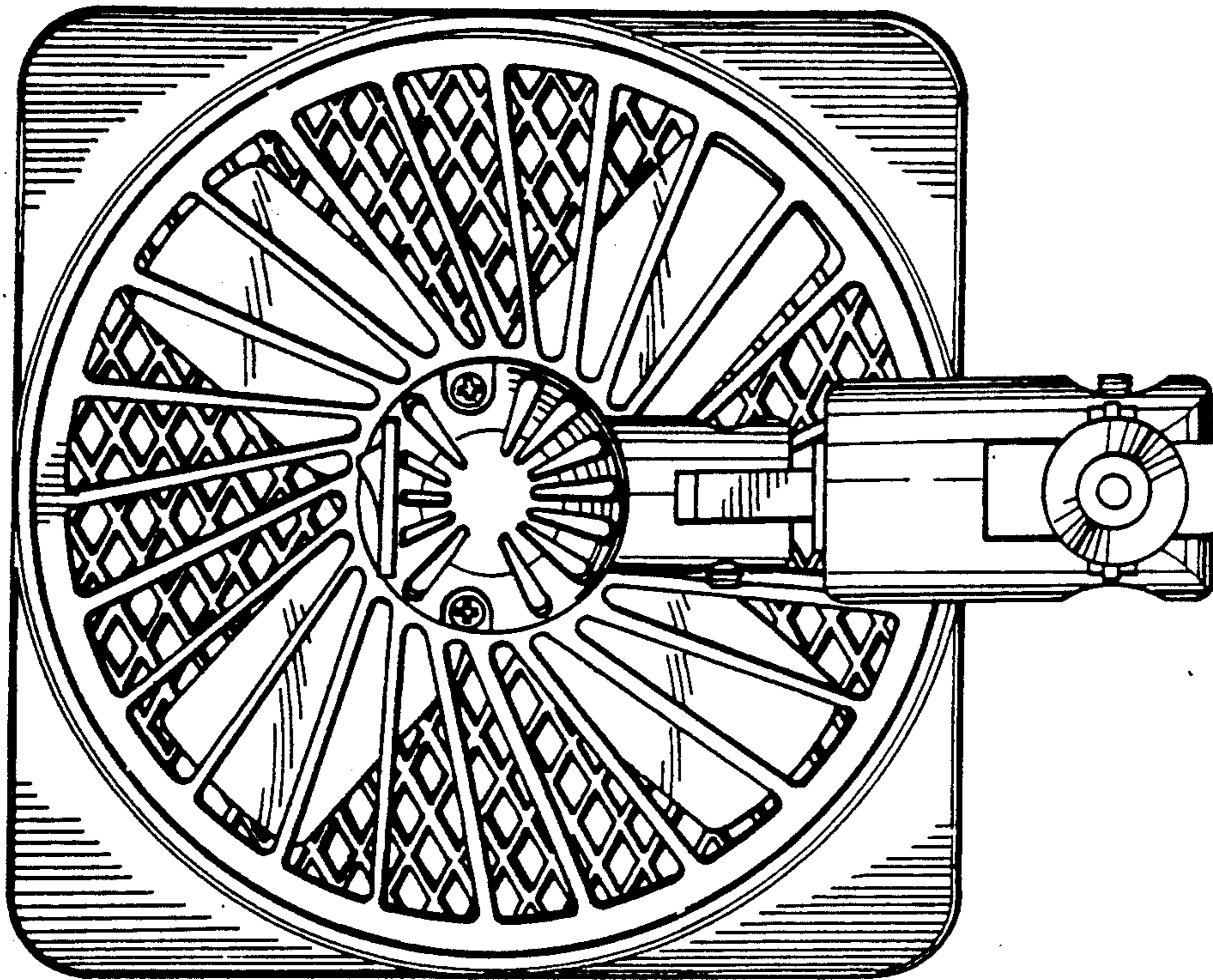

FIG. 3

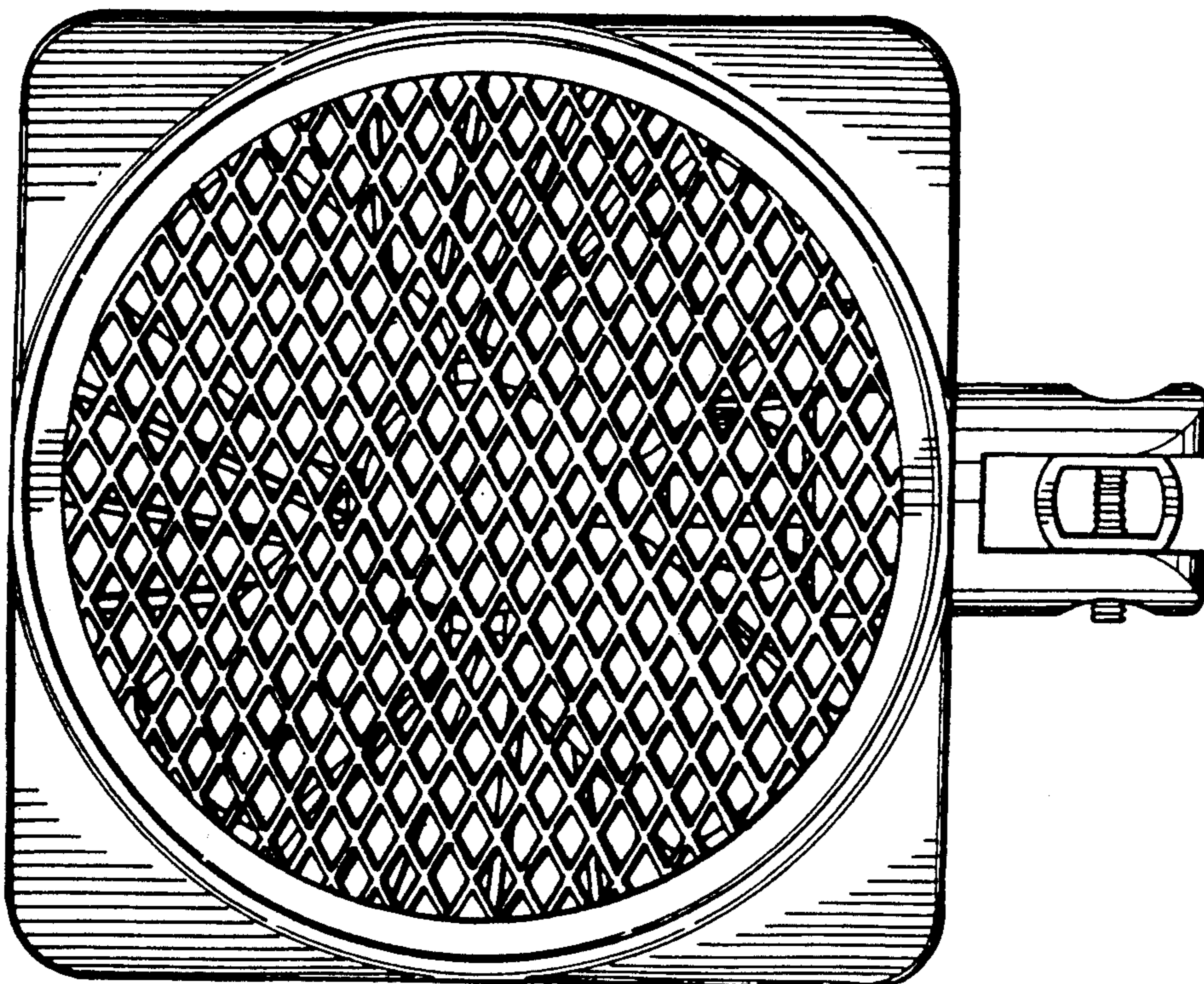

FIG. 2

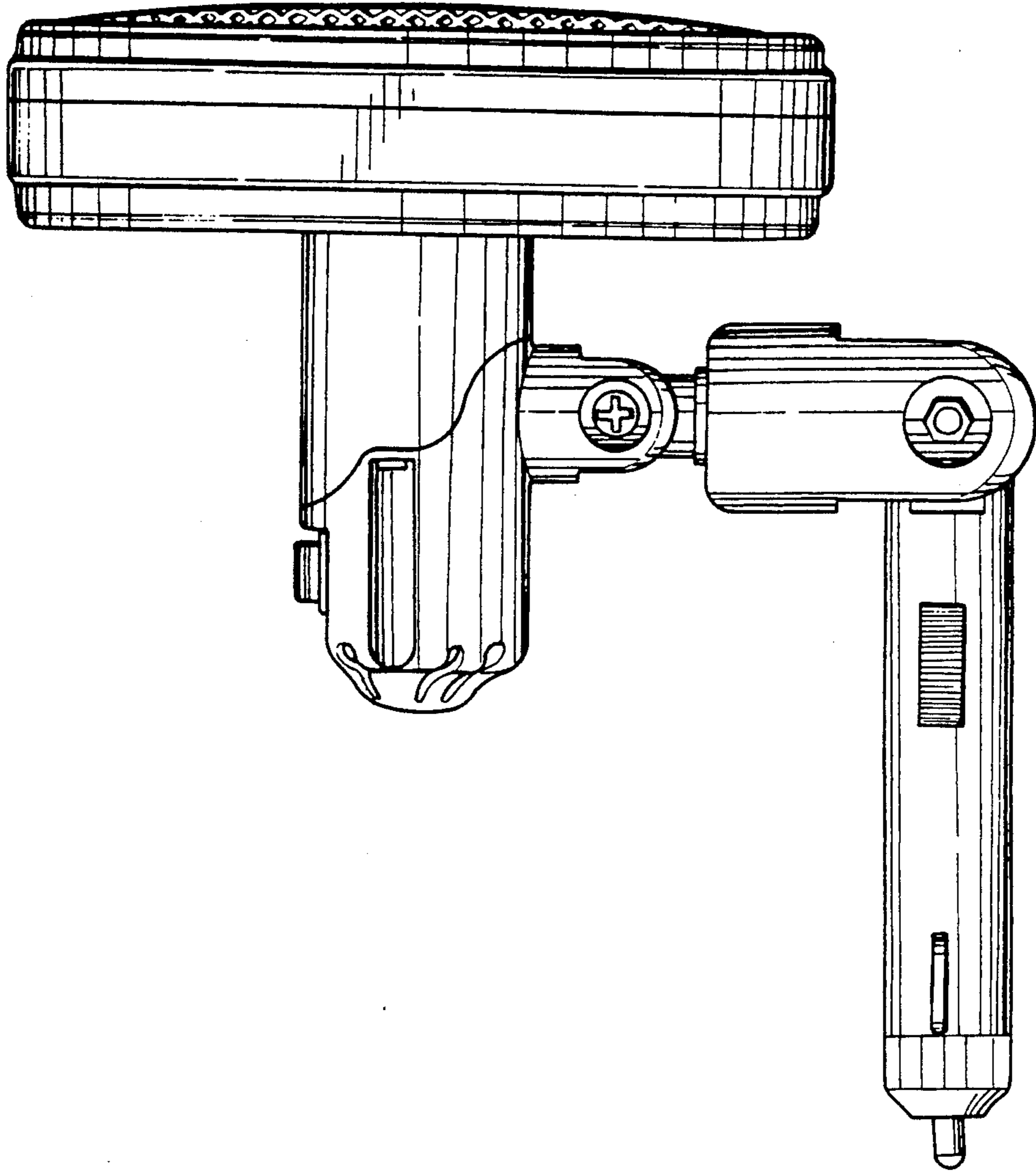

FIG. 4

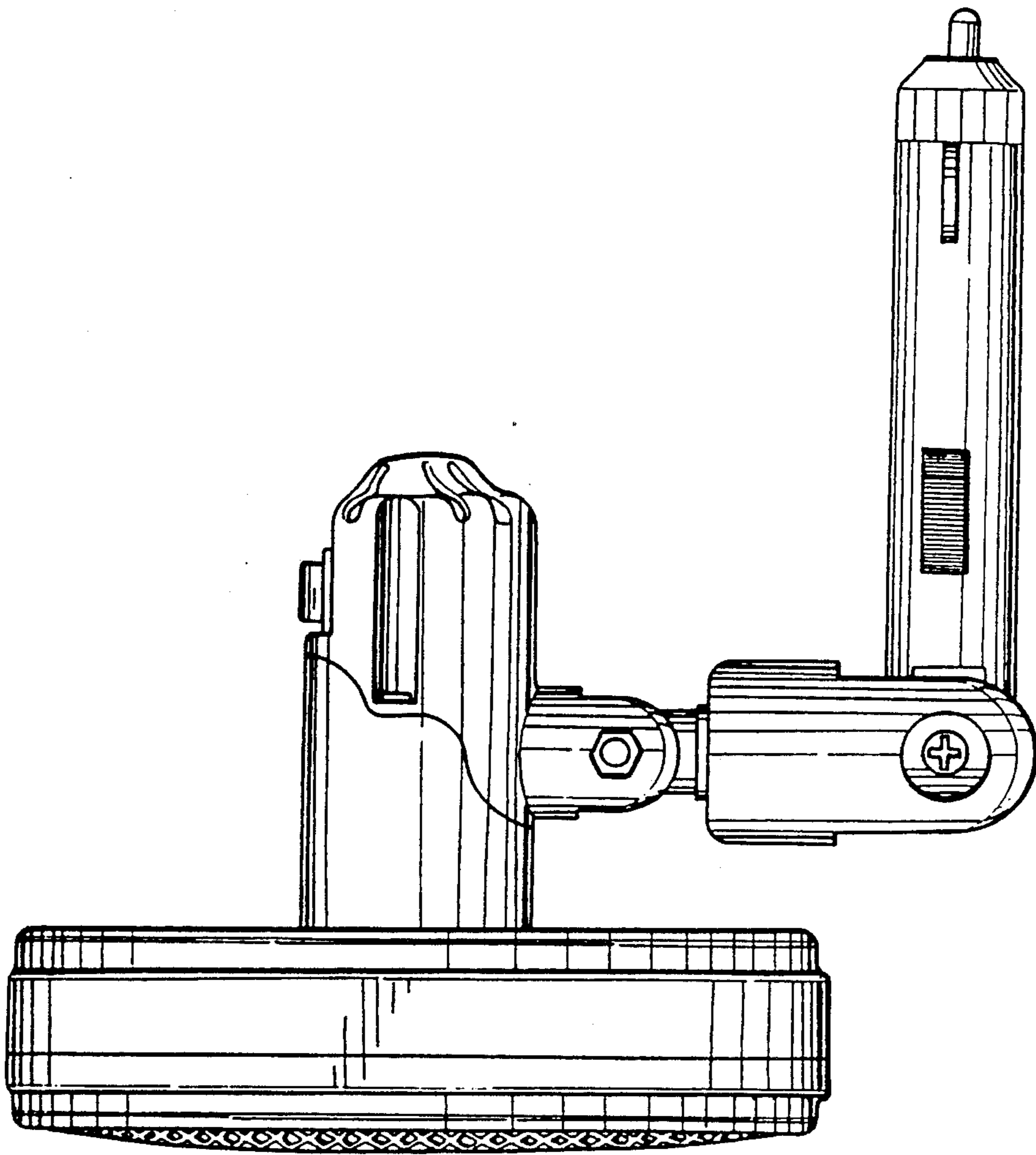

FIG. 5

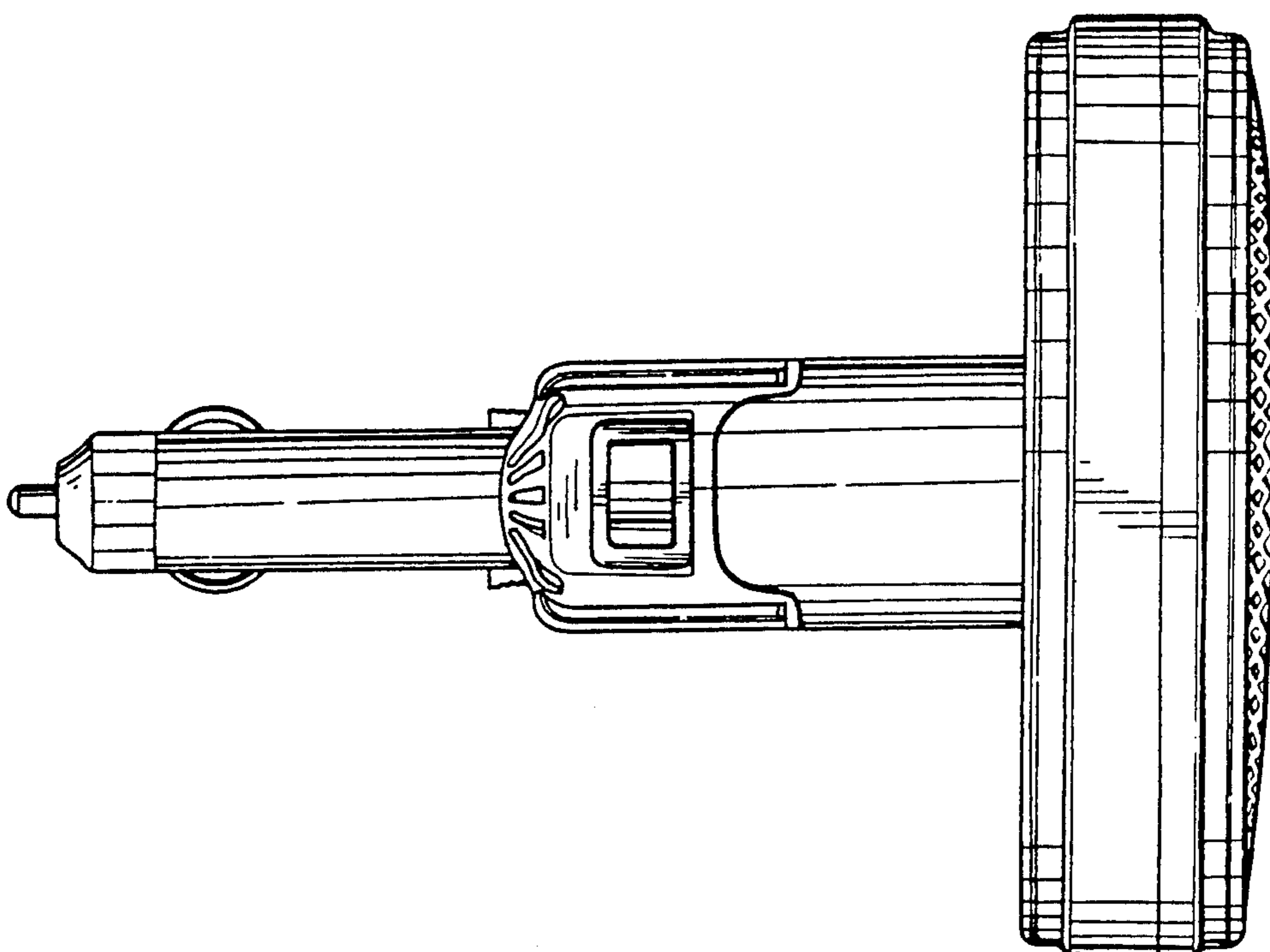

FIG. 6

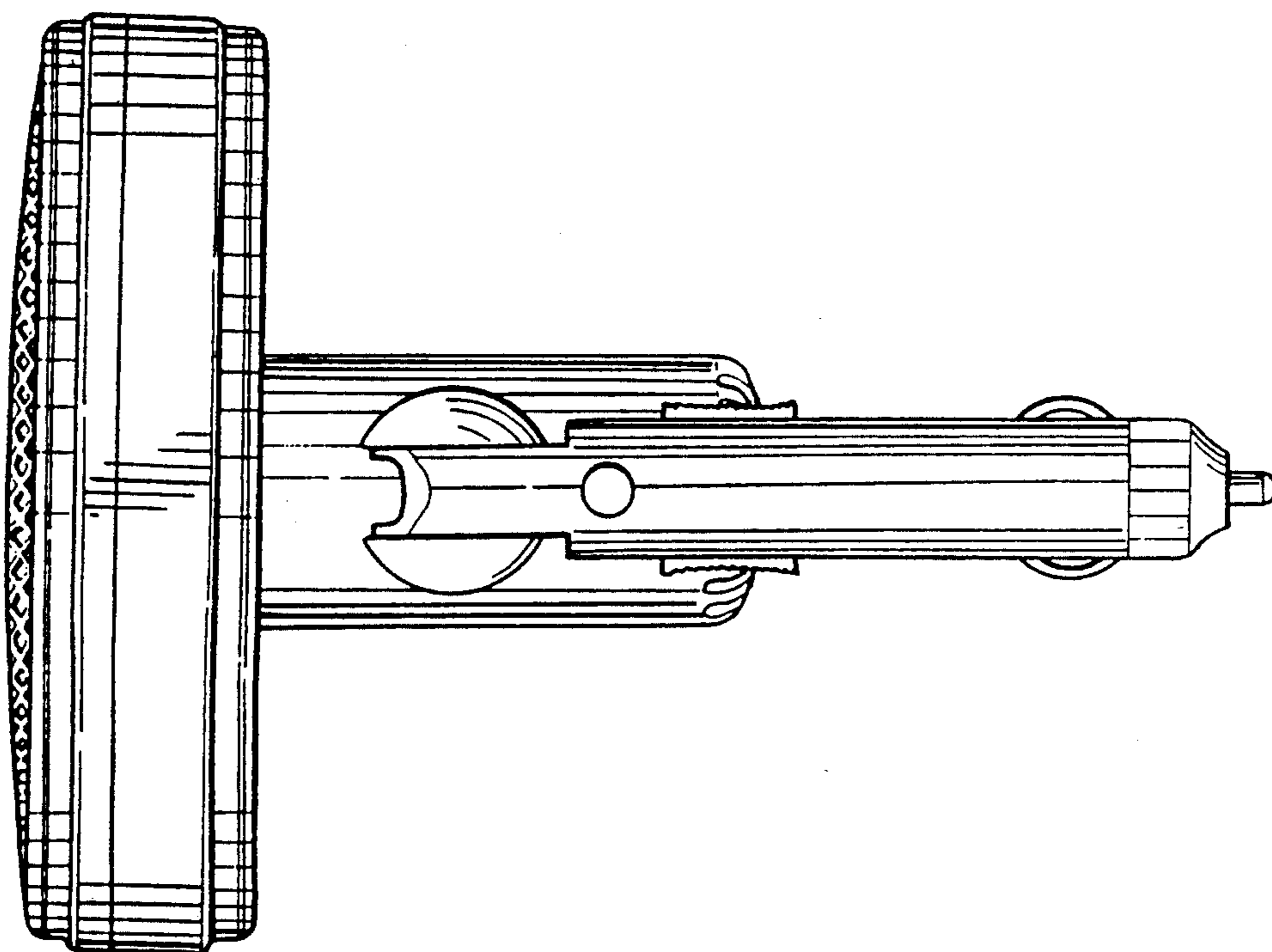

FIG. 7