

[54] VEHICLE WHEEL

[75] Inventor: Marco Cattaneo, Pavia, Italy

[73] Assignee: Momo S.p.A., Milan, Italy

[\*\*] Term: 14 Years

[21] Appl. No.: 214,147

[22] Filed: Jun. 30, 1988

[30] Foreign Application Priority Data

Jan. 26, 1988 [IT] Italy ..... 20507 B/88  
[52] U.S. Cl. .... D12/206; D12/209  
[58] Field of Search ..... D12/206, 209, 211, 204;  
301/63 R, 64 R, 64 SD, 65

[56] References Cited

PUBLICATIONS

Tire Review, 5/86, p. 19W, Dino 33 Wheel, center right side of page.

Tire Review, 9/86, p. 107, RW Wheel No. 3, bottom right side of page.

1987 Tread Design Guide, p. 92, Mangels/Champlite Series 170/Maglite Wheel, second wheel in from bottom right side of page.

Primary Examiner—James M. Gandy

Attorney, Agent, or Firm—Fleit, Jacobson, Cohn, Price, Holman & Stern

[57] CLAIM

The ornamental design for a vehicle wheel, as shown.

DESCRIPTION

FIG. 1 is a perspective view of my new vehicle wheel; FIG. 2 is a front elevation view thereof; FIG. 3 is a rear elevation view thereof; and FIG. 4 is a side elevation view thereof.

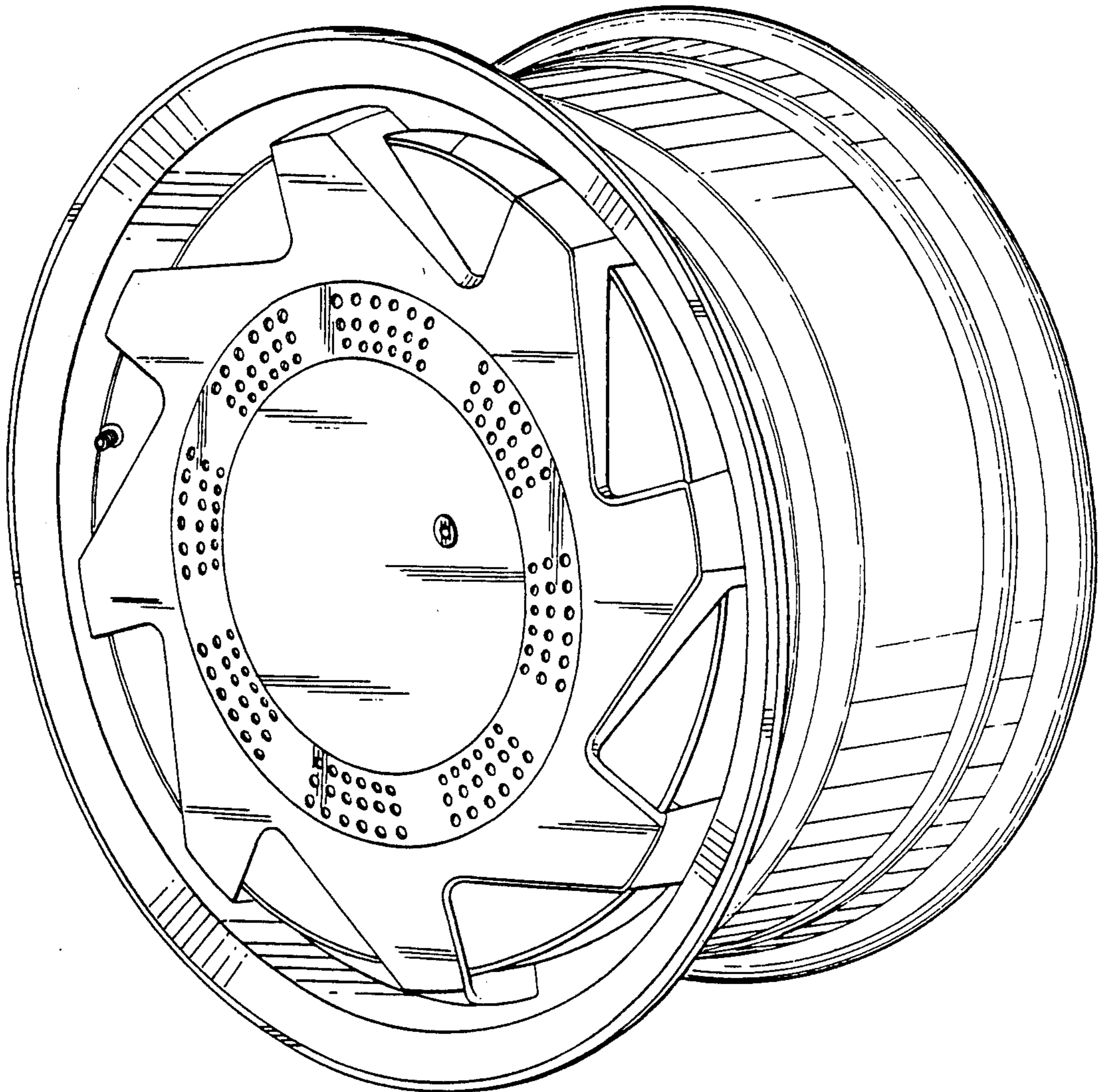

Fig. 1

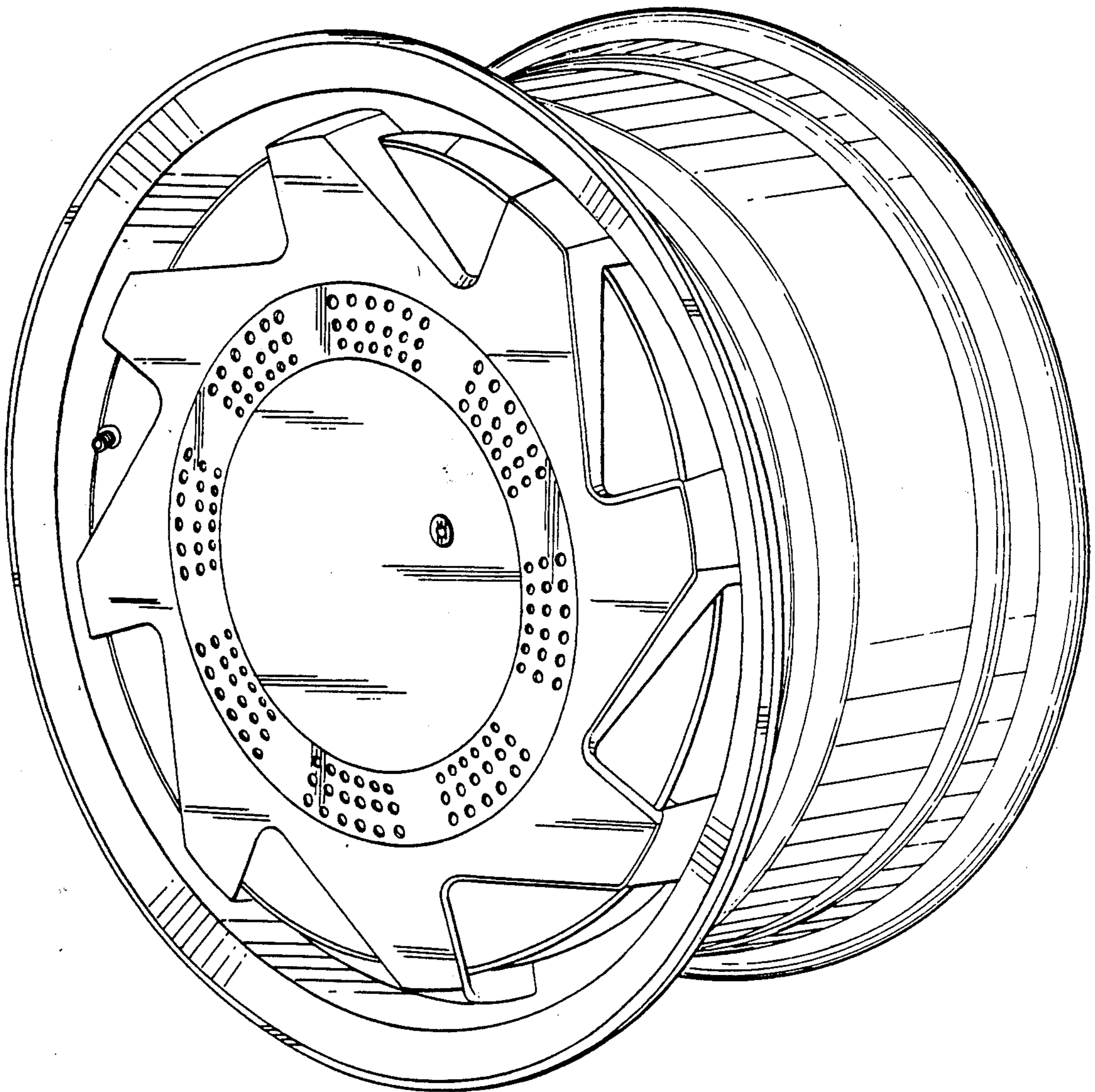



Fig. 2

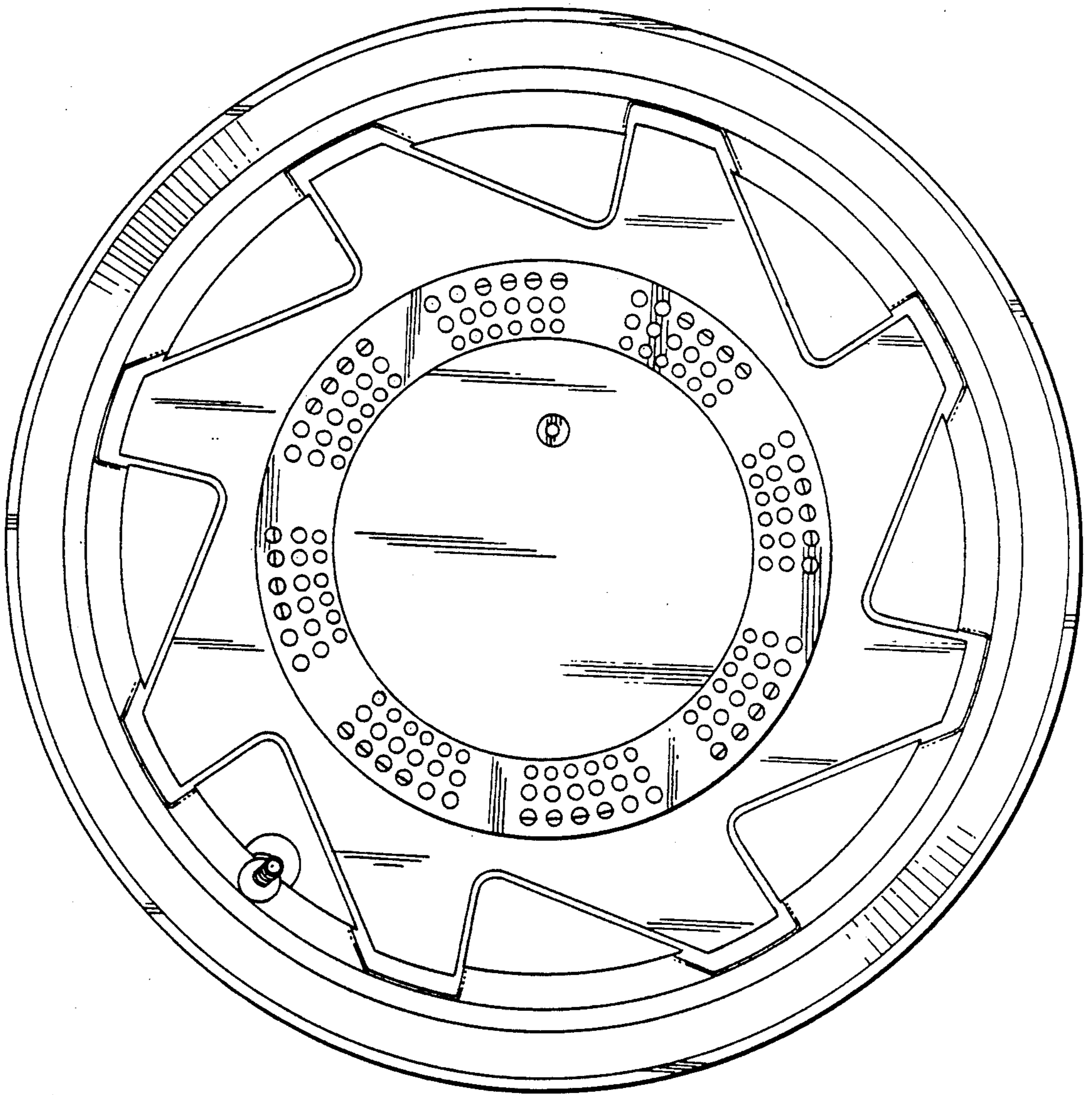

Fig.3

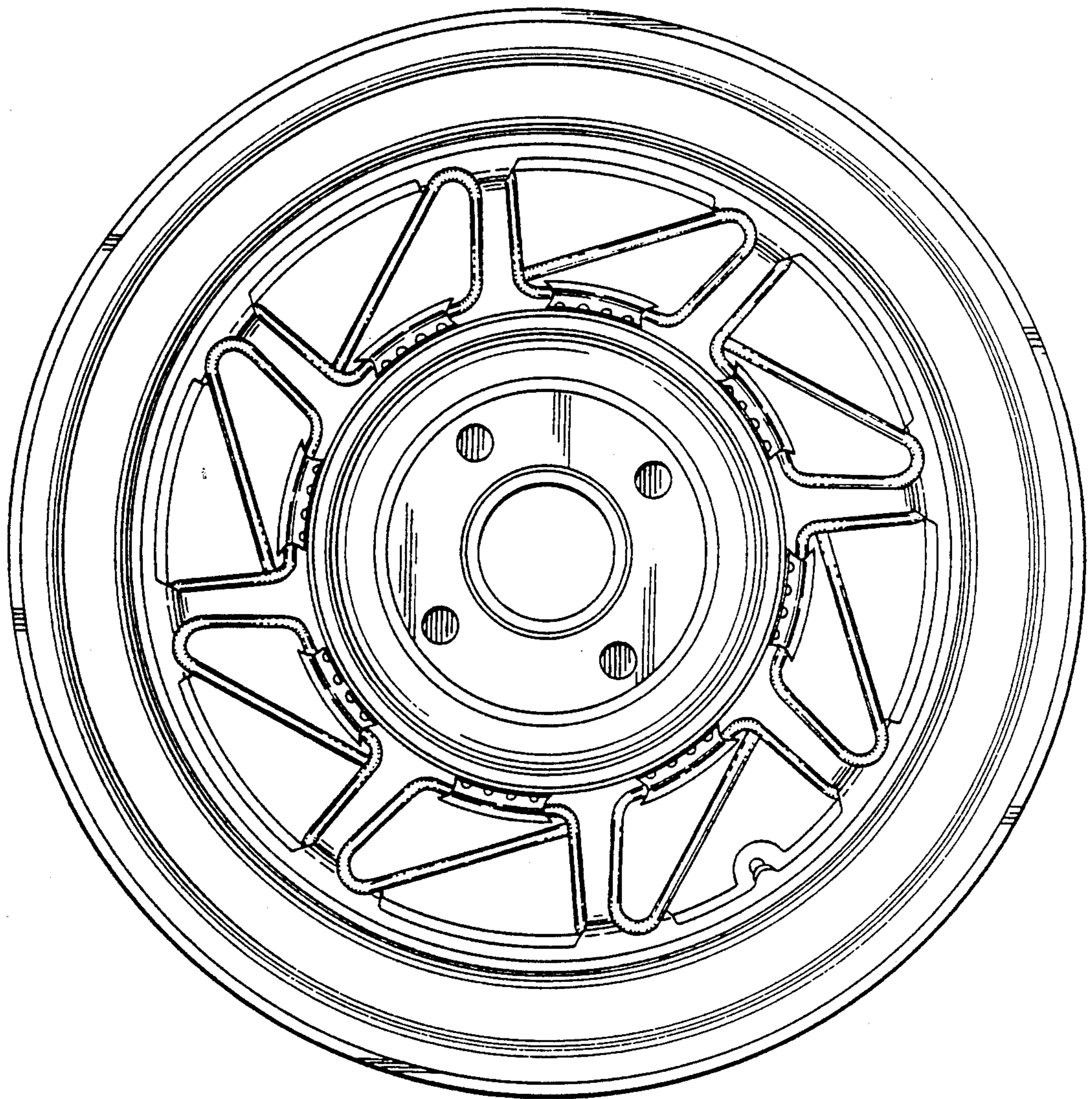

Fig. 4

