

[54] **STEP UNIT FOR A VEHICLE**

[76] **Inventor: Paul Springer, 30412 NE. 104th Ave., Battleground, Wash. 98604**

[**] **Term: 14 Years**

[21] **Appl. No.: 406,755**

[22] **Filed: Sep. 12, 1989**

[52] **U.S. Cl. D12/203**

[58] **Field of Search D12/203; D25/62, 68, D25/69; 280/163, 164.2, 166; 182/53, 54, 55, 57, 59, 92, 127, 150, 228**

[56] **References Cited**

U.S. PATENT DOCUMENTS

D. 214,558 7/1969 Mulford D12/203
D. 270,474 9/1983 Haines et al. D25/62
3,756,622 9/1973 Pyle et al. D12/203

Primary Examiner—James M. Gandy
Attorney, Agent, or Firm—Klarquist, Sparkman,
Campbell, Leigh & Whinston

[57] **CLAIM**

The ornamental design for a step unit for a vehicle, as shown and described.

DESCRIPTION

FIG. 1 is a top side perspective view of a step unit for a vehicle in accordance with my new design;
FIG. 2 is a rear elevational view thereof;
FIG. 3 is a top plan view thereof;
FIG. 4 is a bottom plan view thereof;
FIG. 5 is a front elevational view thereof;
FIG. 6 is a right side elevational view thereof;
FIG. 7 is a top side perspective view of a second embodiment of a step unit for a vehicle in accordance with my new design;
FIG. 8 is a rear elevational view of the design of FIG. 7;
FIG. 9 is a top plan view of the design of FIG. 7;
FIG. 10 is a bottom plan view of the design of FIG. 7;
FIG. 11 is a front elevational view of the design of FIG. 7;
FIG. 12 is a right side elevational view of the design of FIG. 7.

The broken line showing a portion of a vehicle in FIGS. 1 and 7 is for illustrative purposes only and forms no part of the claimed design.

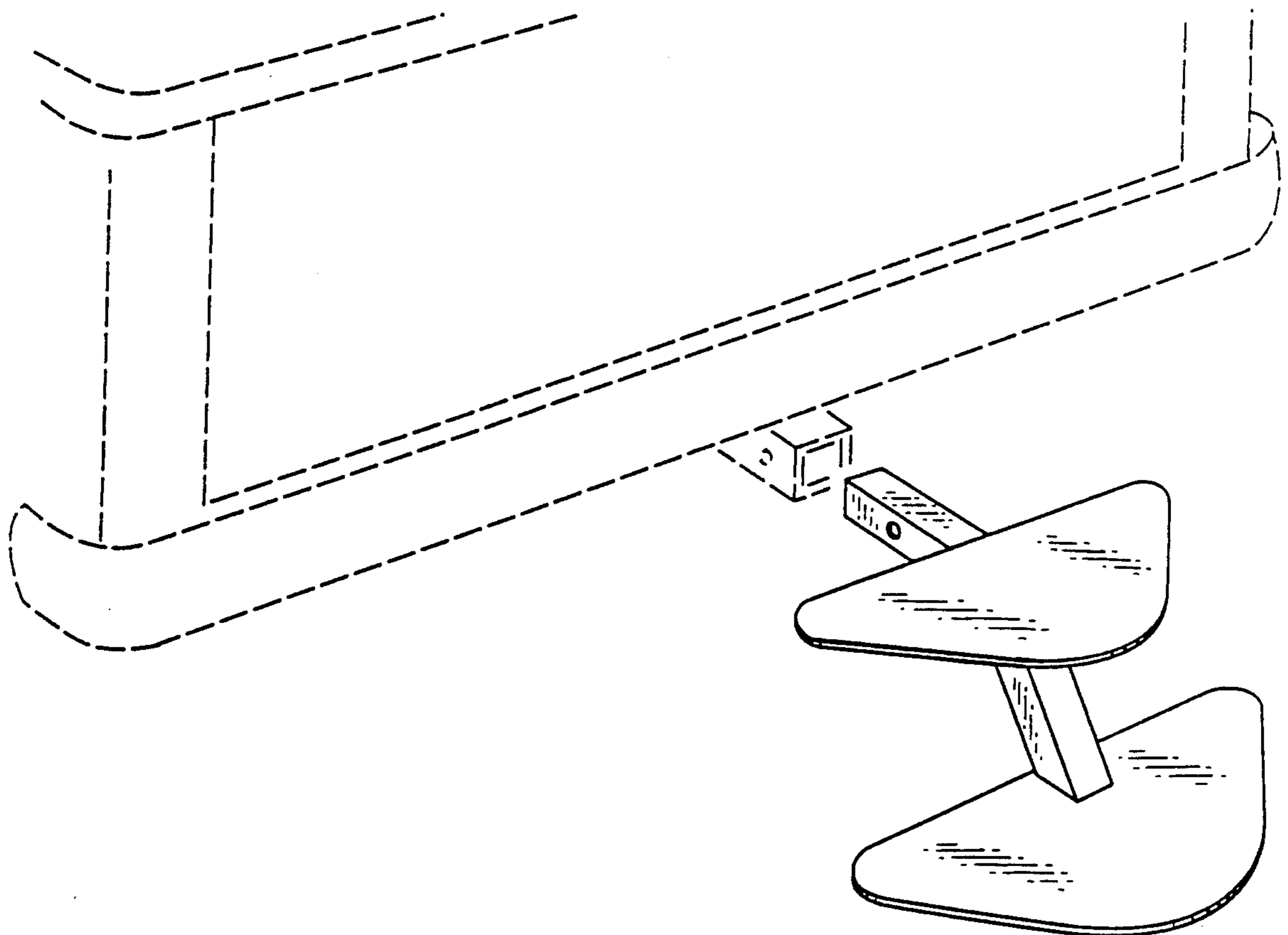

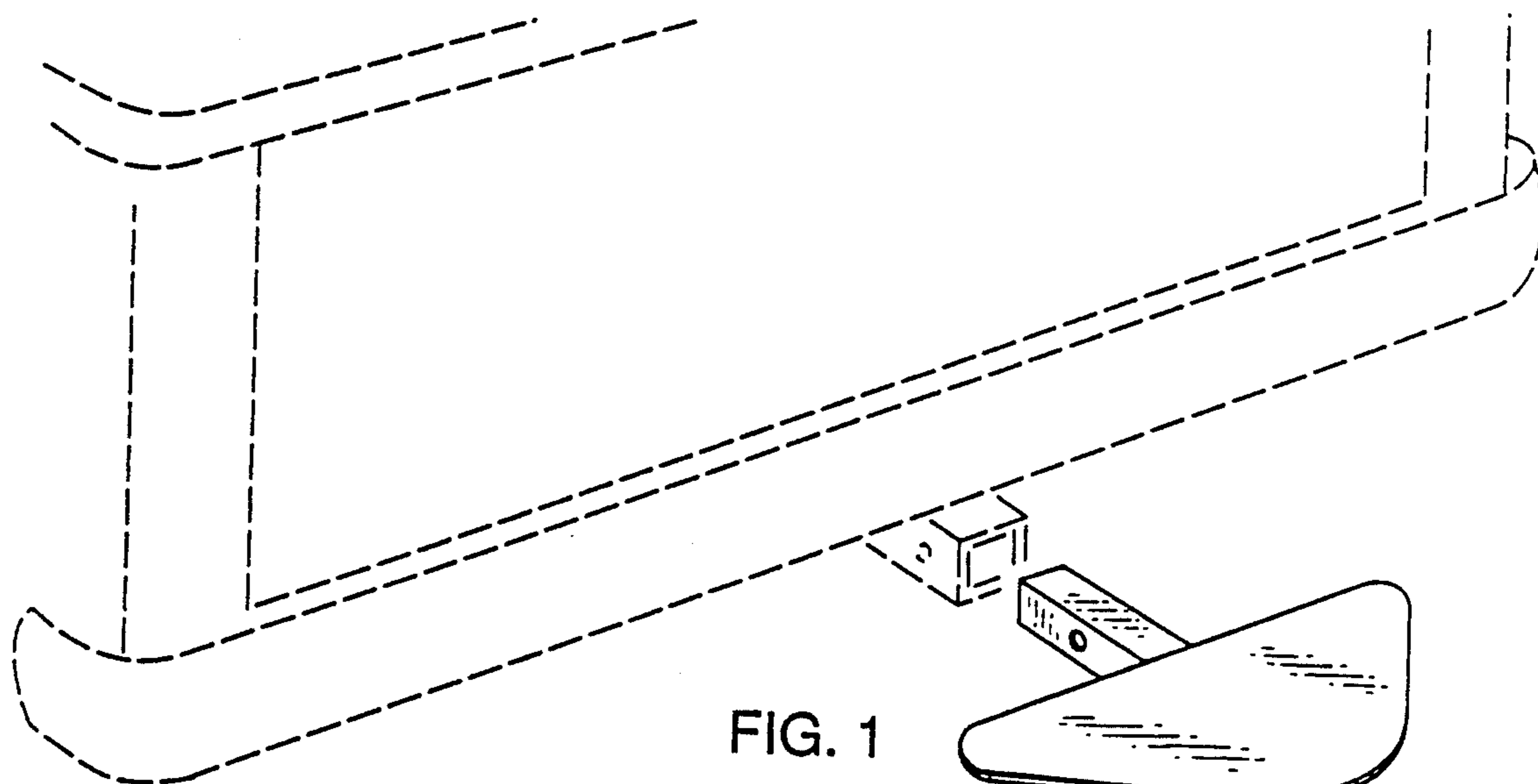

FIG. 1

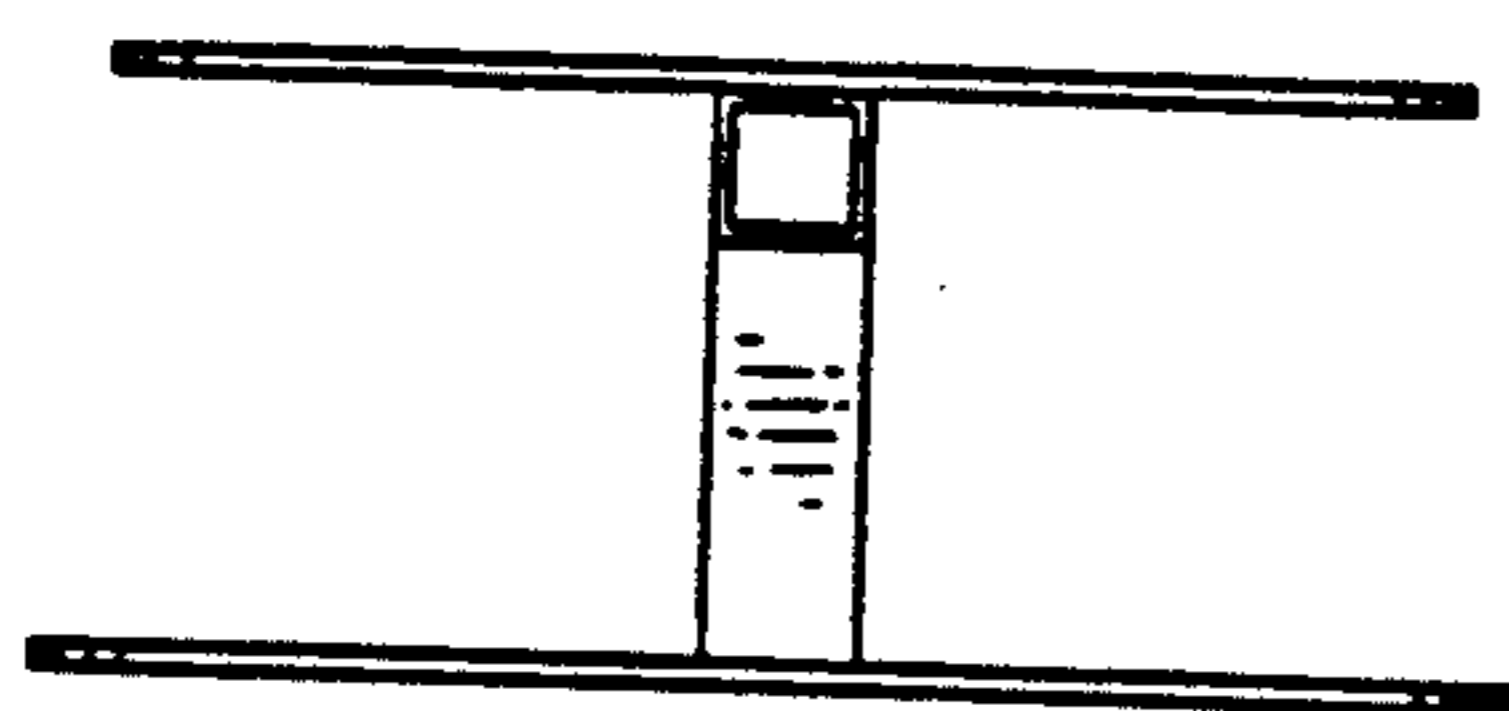

FIG. 2

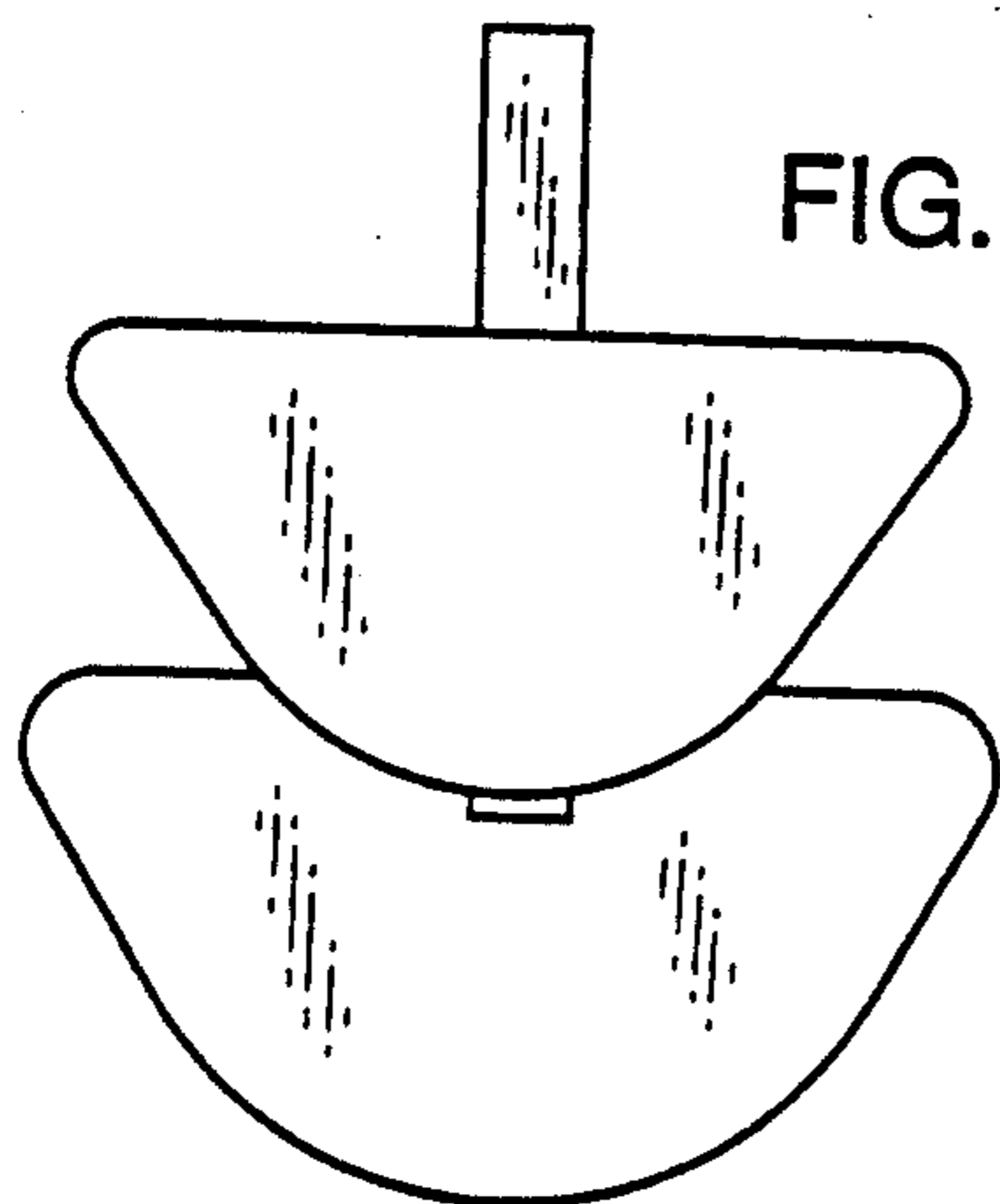

FIG. 3

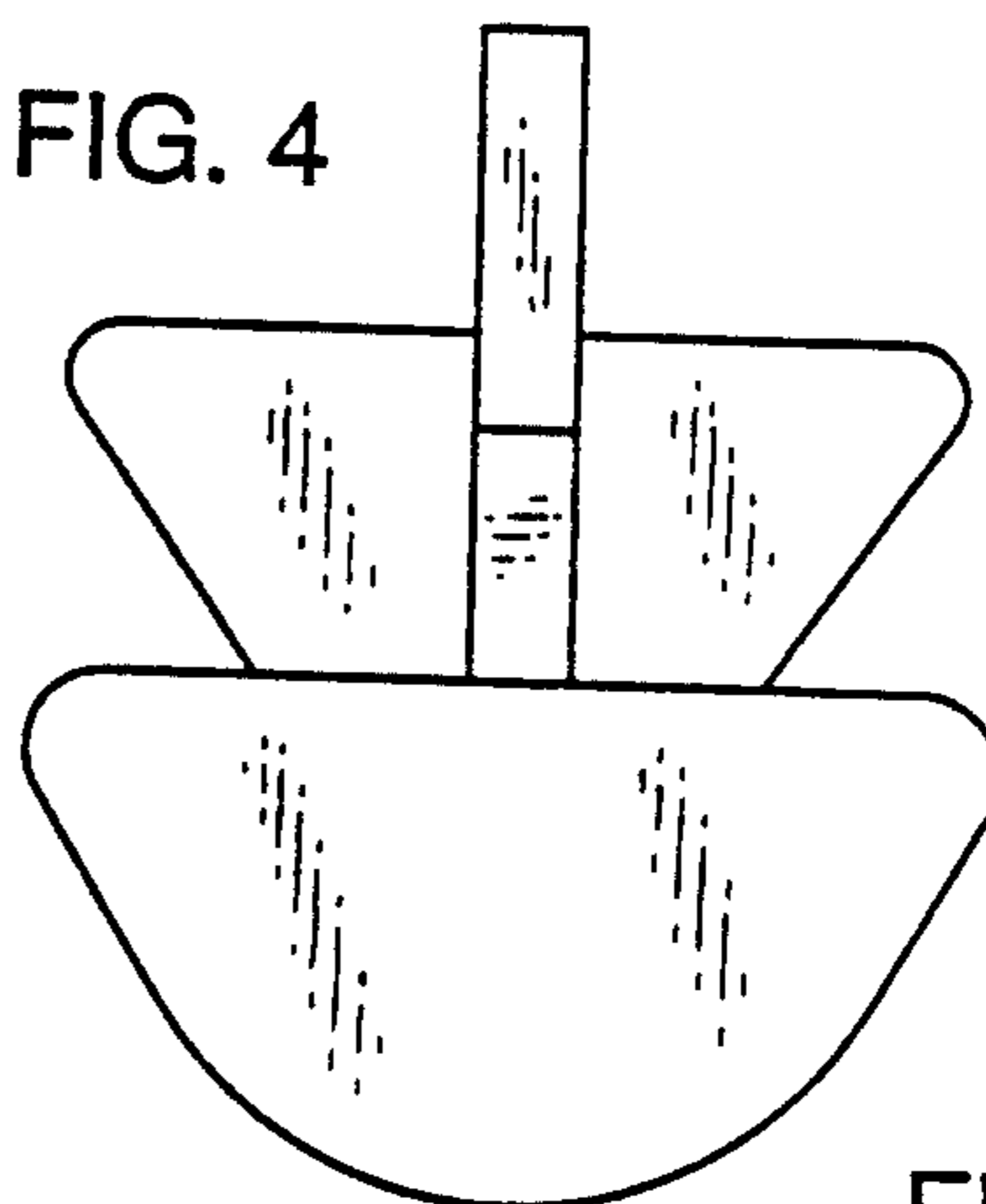

FIG. 4

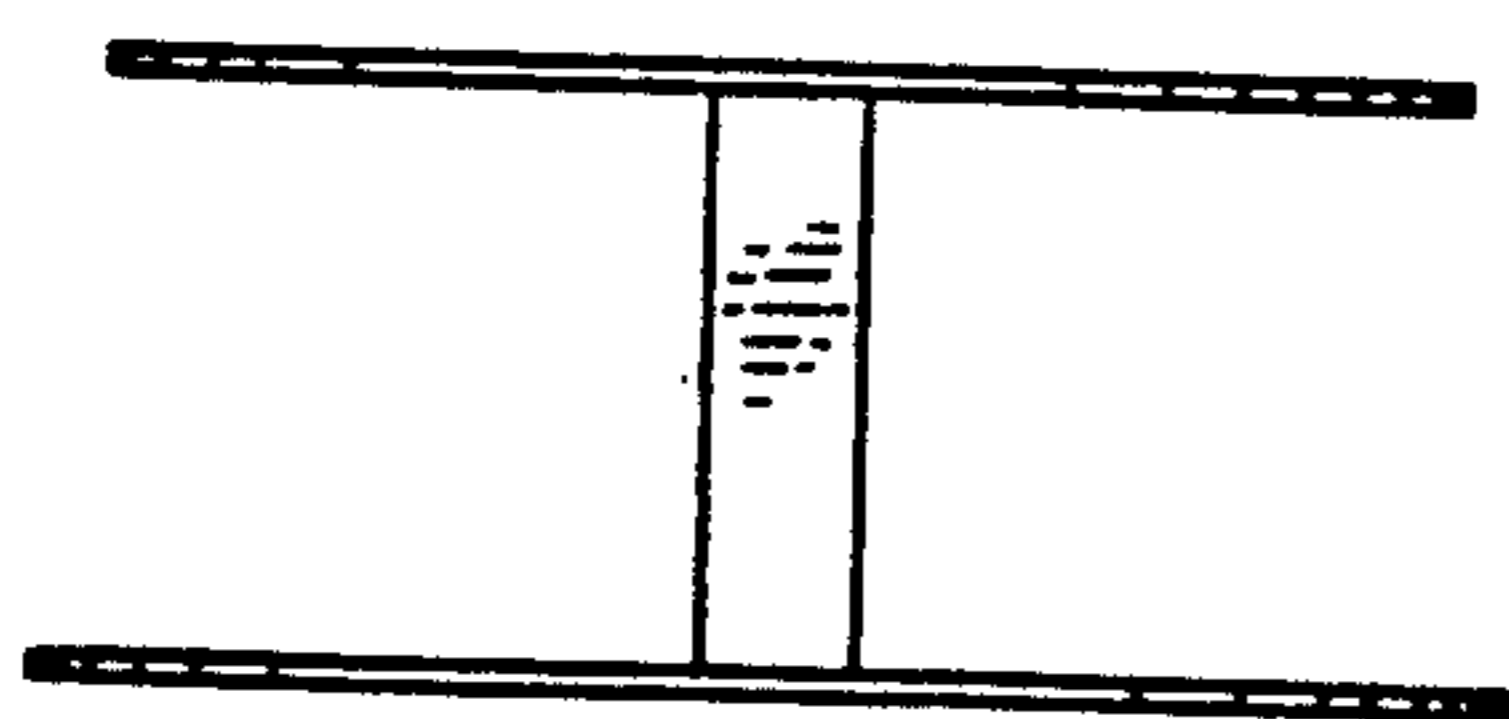

FIG. 5

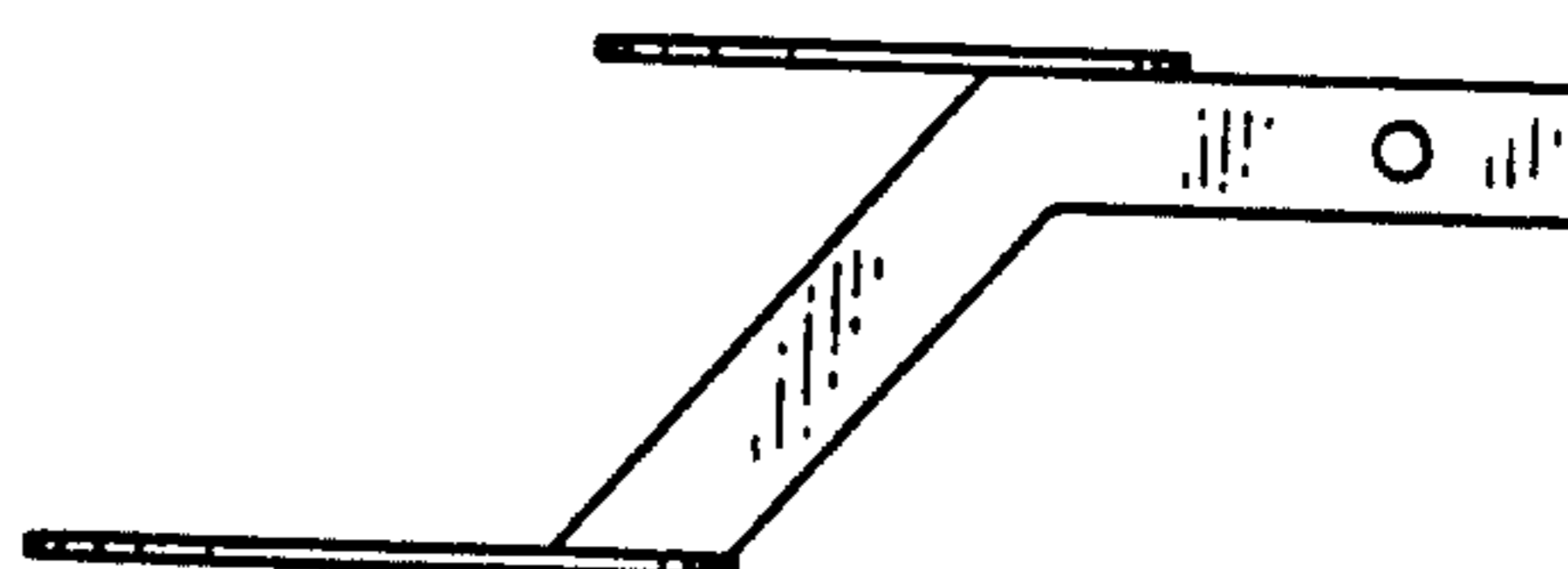

FIG. 6

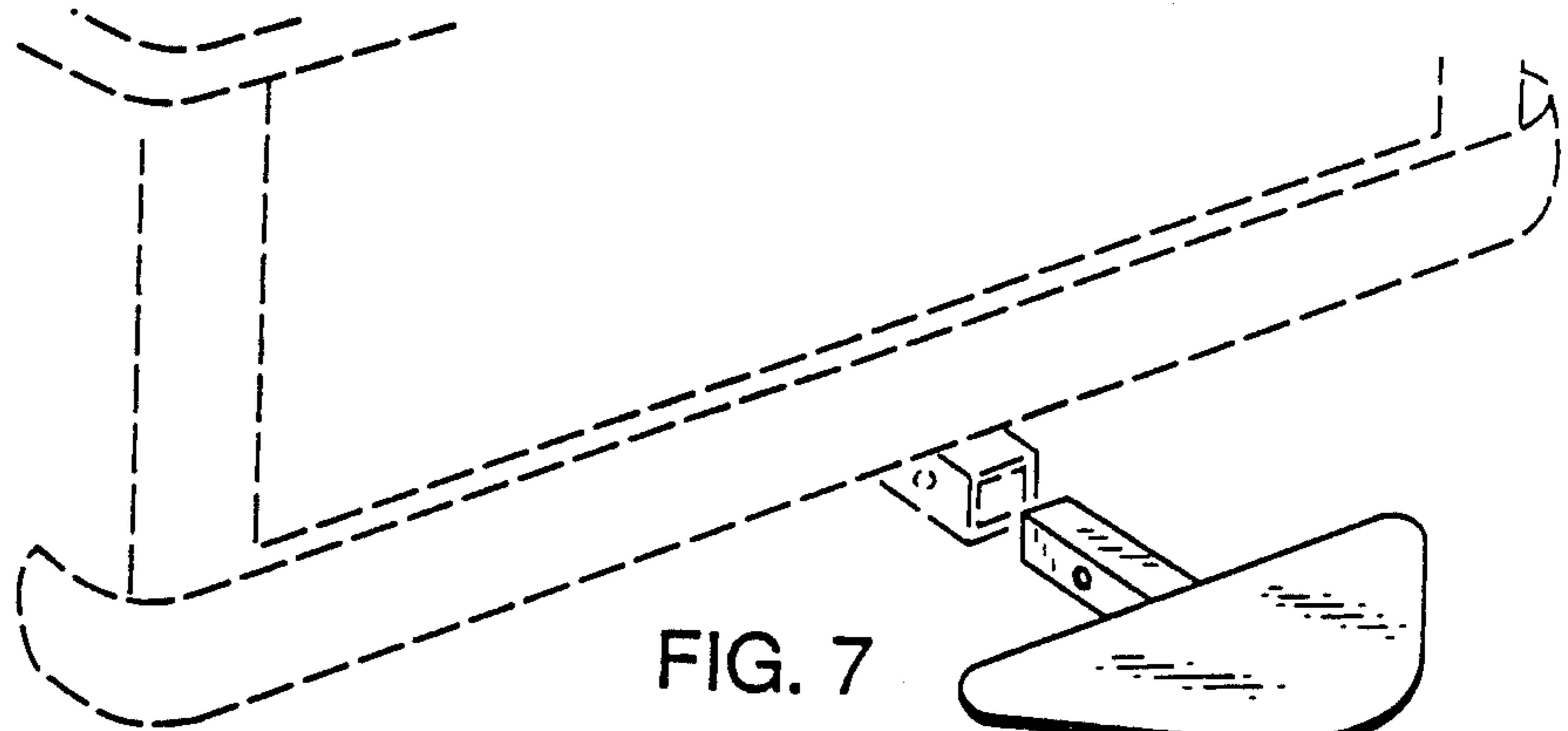

FIG. 7

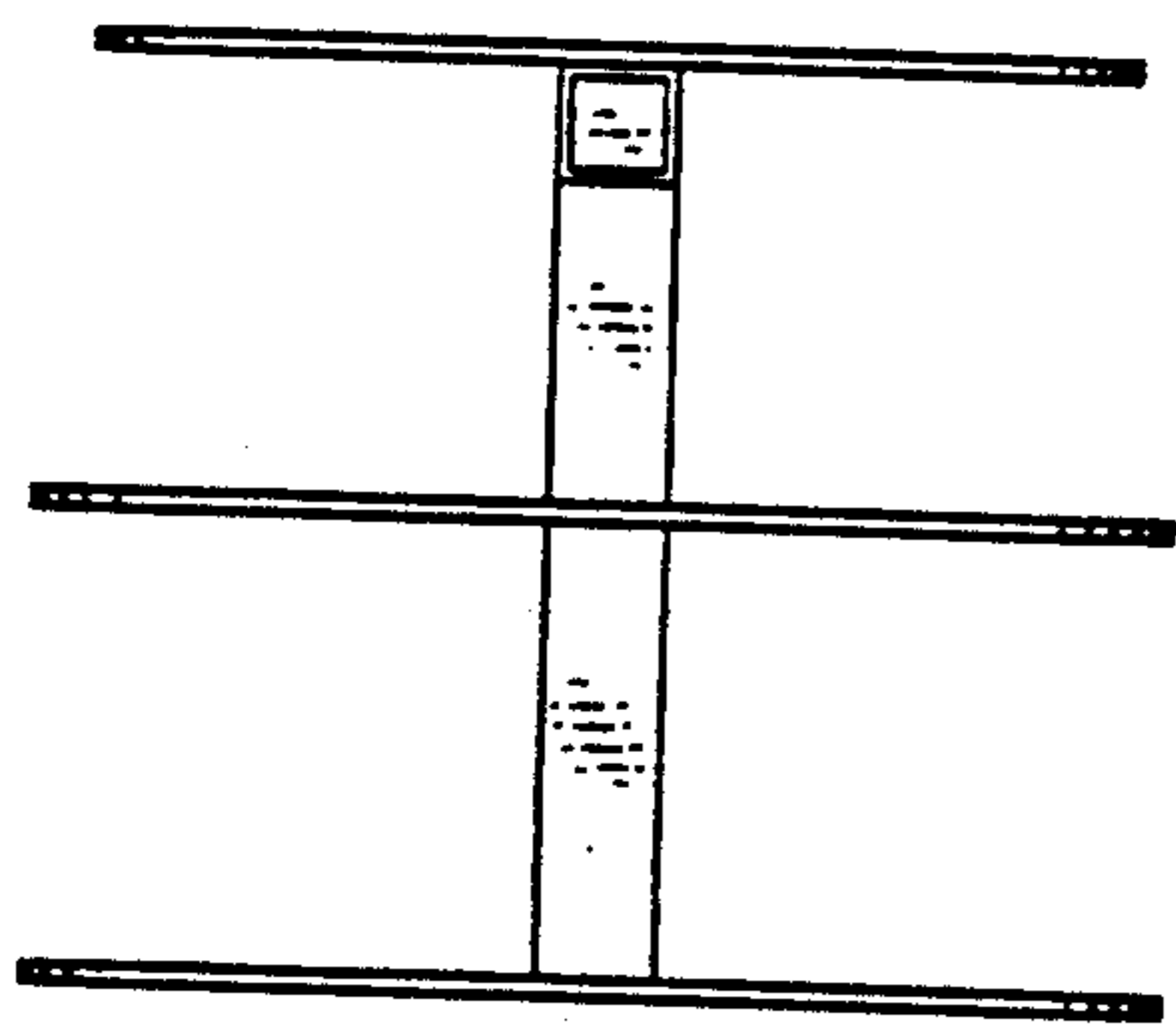

FIG. 8

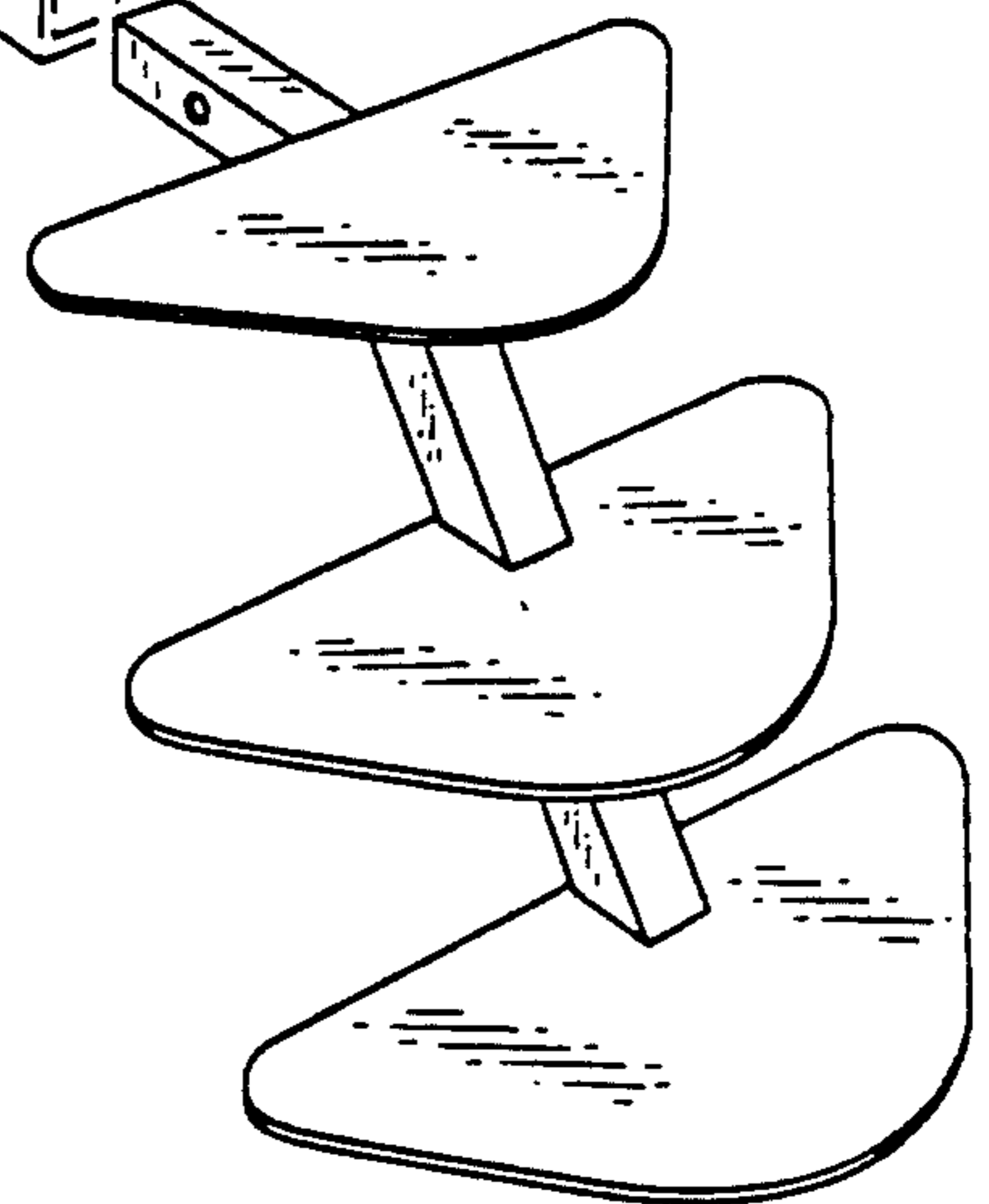

FIG. 9

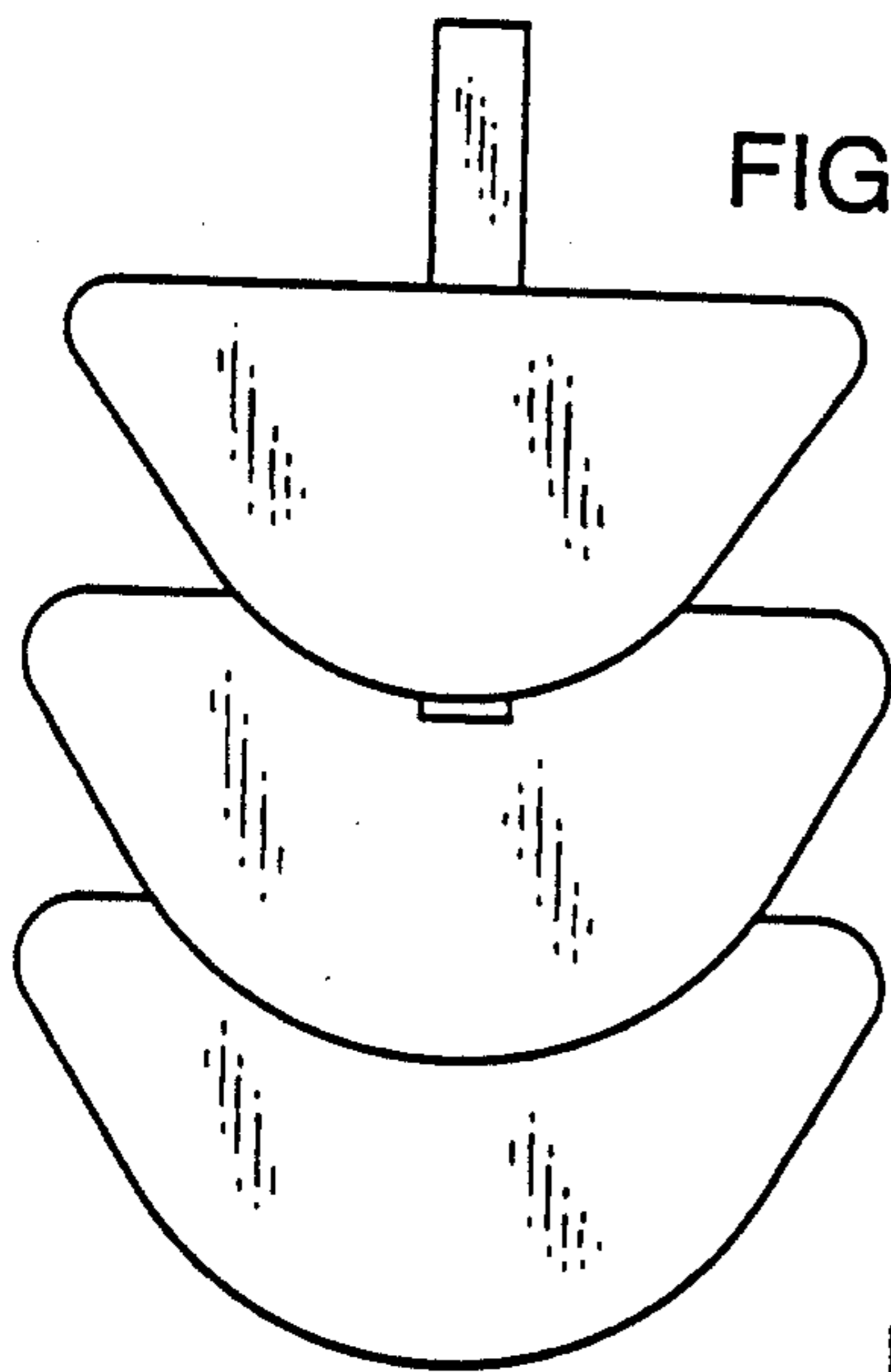

FIG. 10

FIG. 11

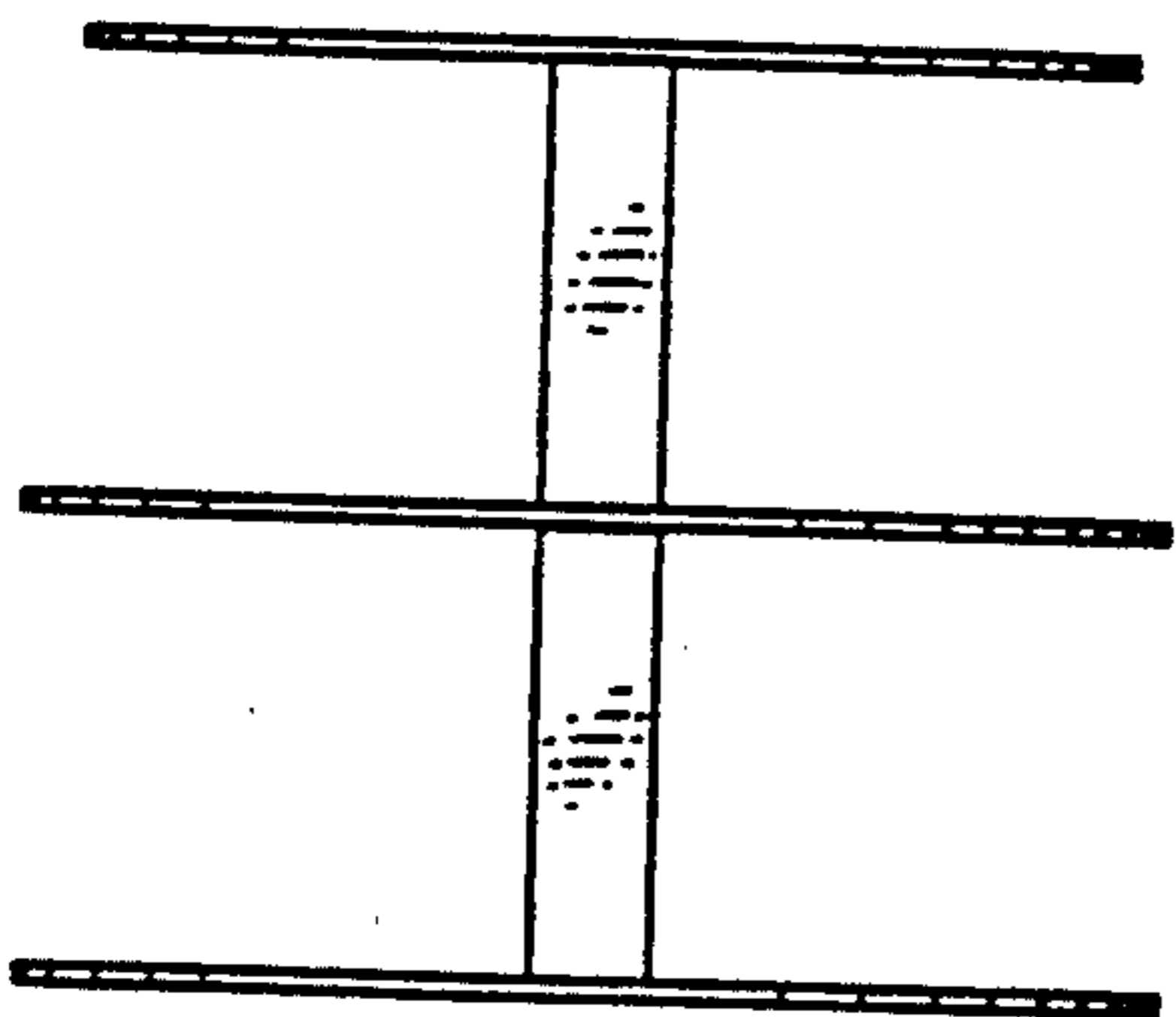

FIG. 12