

[54] **MULTIPLE CALIPER AND SCALE CARD**

[76] **Inventor: Joseph Grayzel, 262 Fountain Rd., Englewood, N.J. 07631**

[\*\*] **Term: 14 Years**

[21] **Appl. No.: 270,303**

[22] **Filed: Nov. 14, 1988**

[52] **U.S. Cl. .... D10/62; D10/73**

[58] **Field of Search ..... D10/62, 64, 65, 70, D10/73; 33/663, 664, 665**

**FOREIGN PATENT DOCUMENTS**

240481 4/1946 Fed. Rep. of Germany .  
 269832 11/1950 Fed. Rep. of Germany .  
 437458 4/1912 France .  
 445972 3/1949 Italy .  
 1219 of 1913 United Kingdom .

*Primary Examiner*—Nelson C. Holtje  
*Assistant Examiner*—Antoine D. Davis

[57] **CLAIM**

The ornamental design for multiple caliper and scale card, as shown.

**DESCRIPTION**

FIG. 1 is a top, front, and right side perspective view of a multiple caliper and scale card showing my new design, with the multiple caliper shown in a closed position;  
 FIG. 2 is a front elevational view;  
 FIG. 3 is a rear elevational view;  
 FIG. 4 is a right elevational view;  
 FIG. 5 is a left side elevational view;  
 FIG. 6 is a top plan view;  
 FIG. 7 is a bottom plan view; and  
 FIG. 8 is a right, front, and bottom perspective view thereof, with the multiple caliper shown in an extended position.

[56] **References Cited**

**U.S. PATENT DOCUMENTS**

D. 220,583	4/1971	Hall .....	D10/70
495,219	4/1893	Goldschmitt .	
774,718	11/1904	Crozier .	
791,235	5/1905	Allen .	
1,050,890	1/1913	Wild .....	33/664
1,258,574	3/1918	Jones .....	33/664
1,643,968	10/1927	Thompson .	
1,696,832	12/1928	Bane .	
2,352,225	12/1980	Fulton .	
2,729,356	1/1956	Gookin .....	33/664
3,271,869	9/1966	Rather .	
4,550,502	11/1985	Grayzel .	

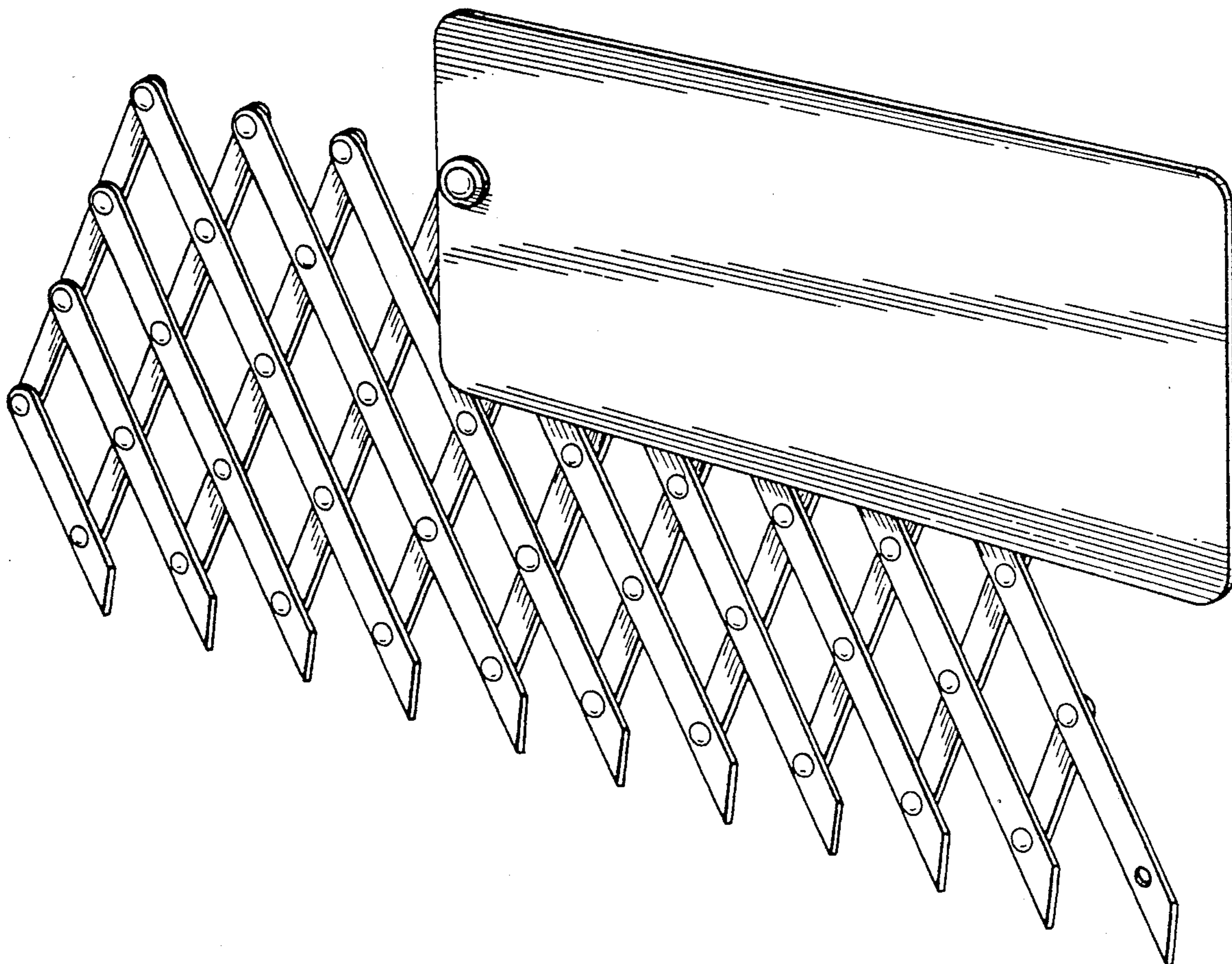

*FIG-1*

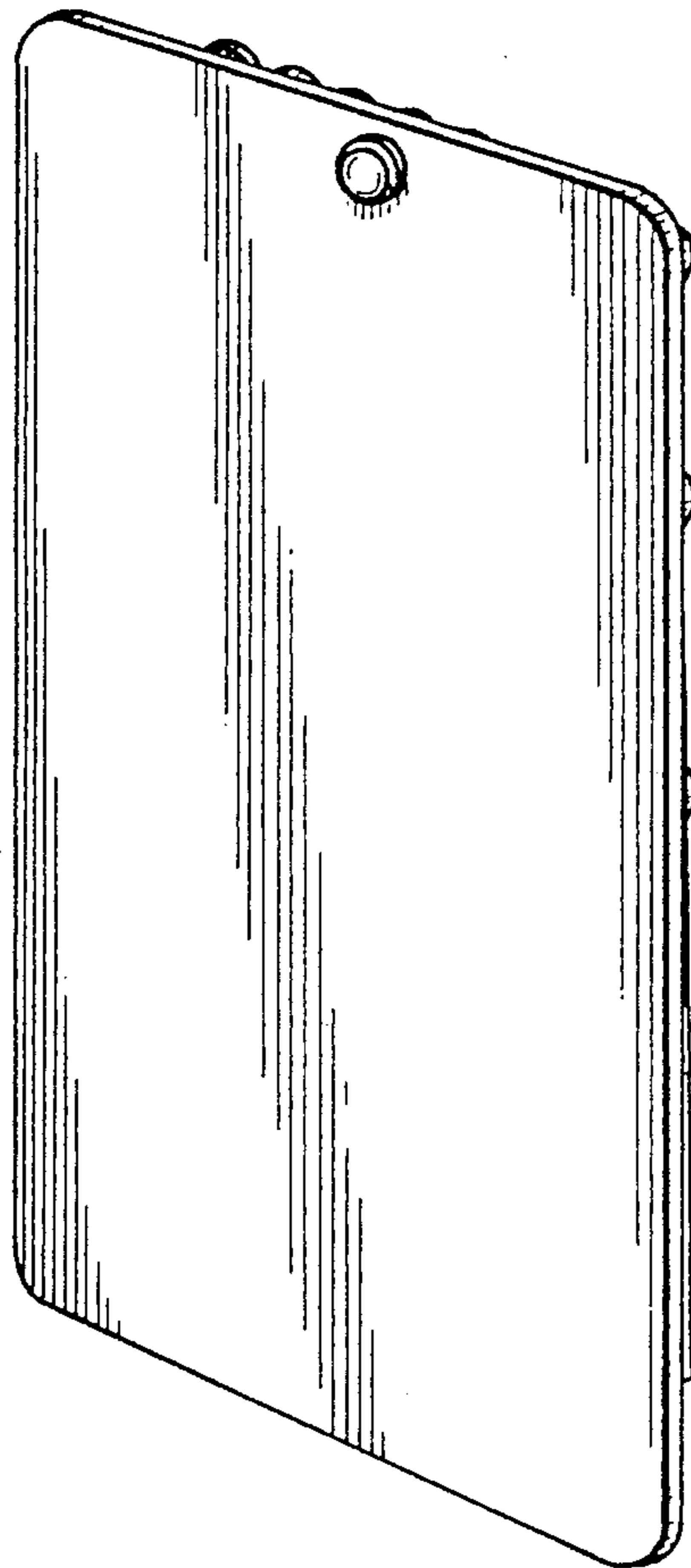

*FIG-2*

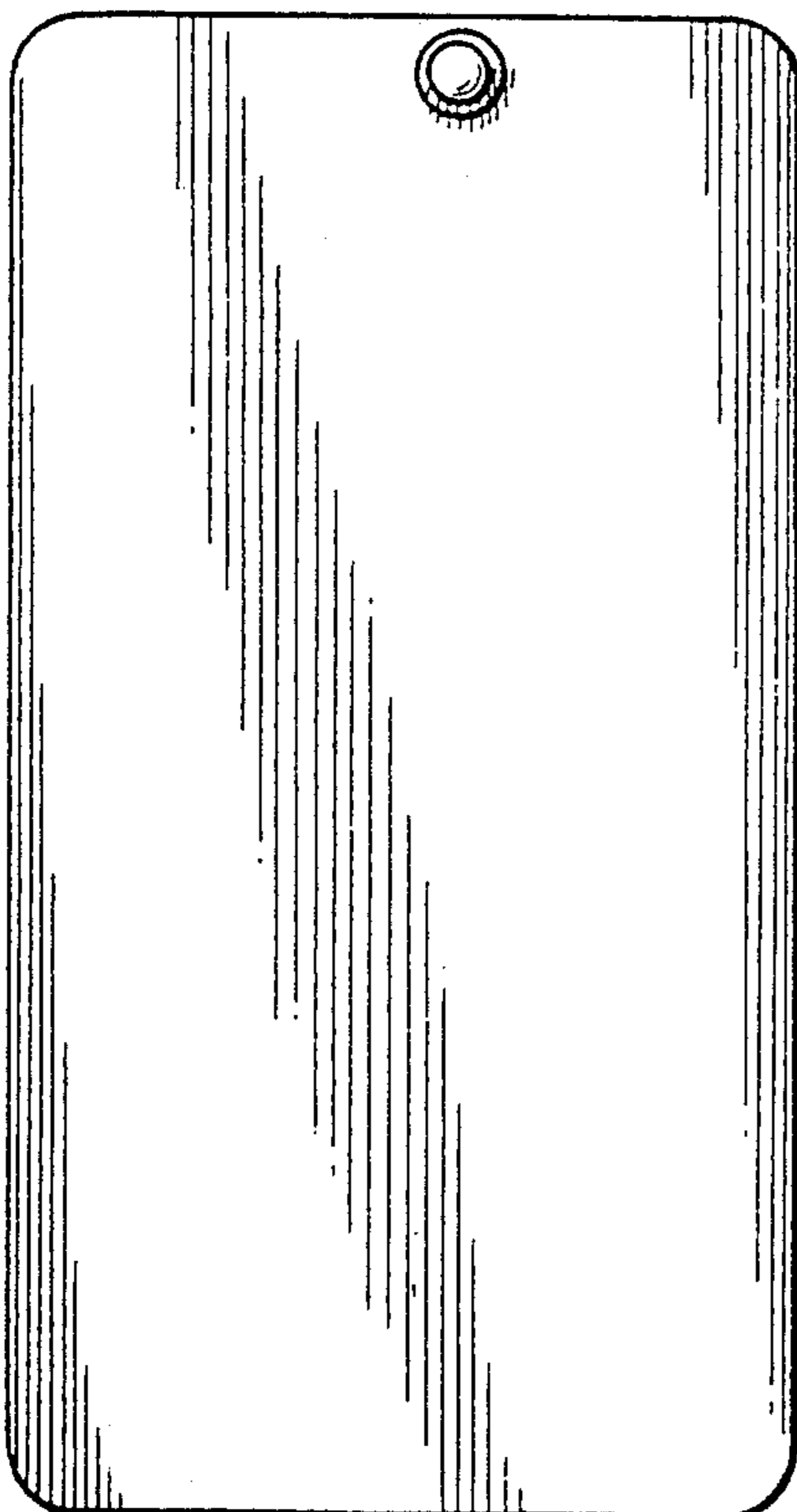

*FIG-3*

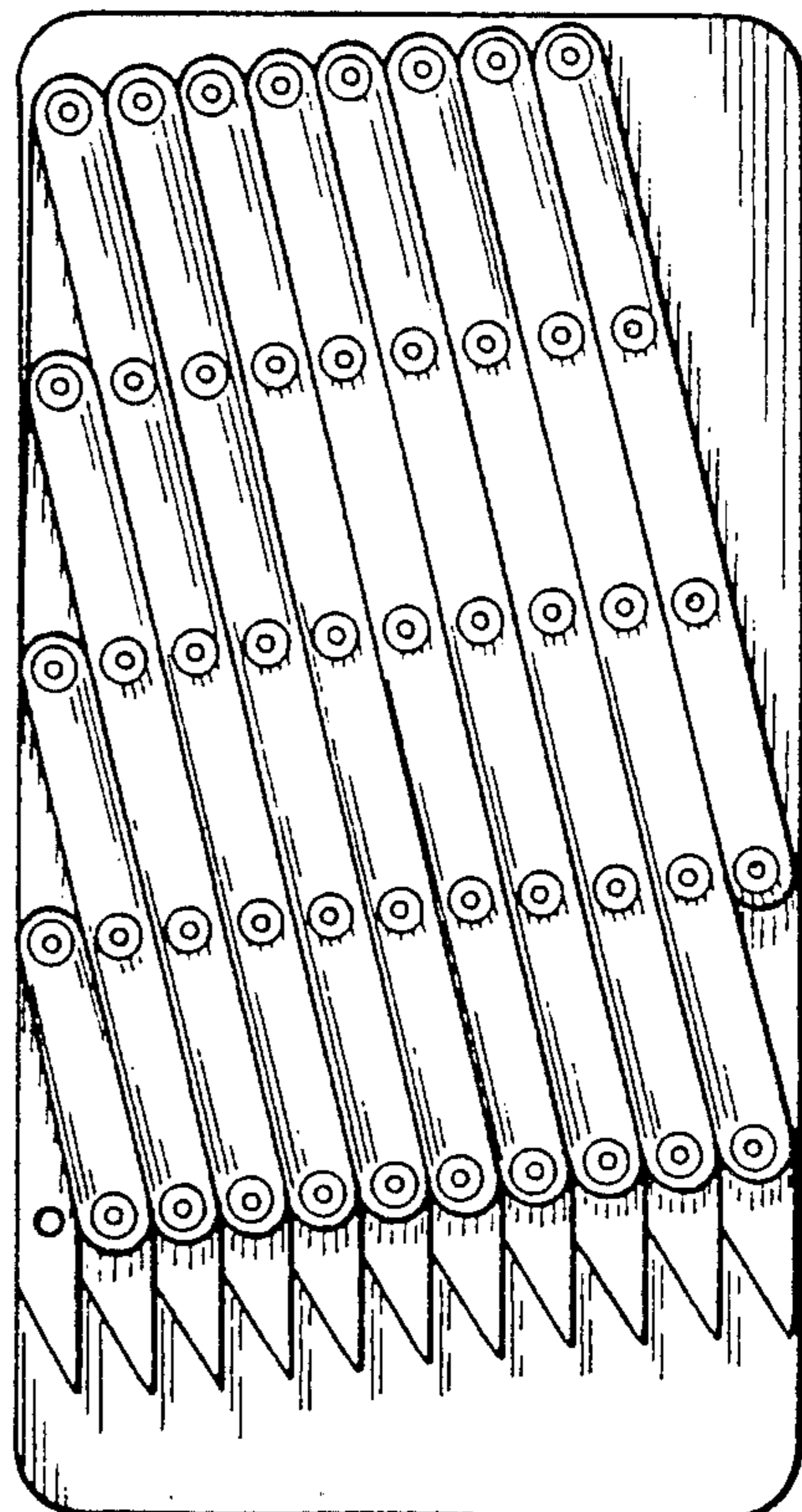

FIG-4



FIG-5



FIG-6

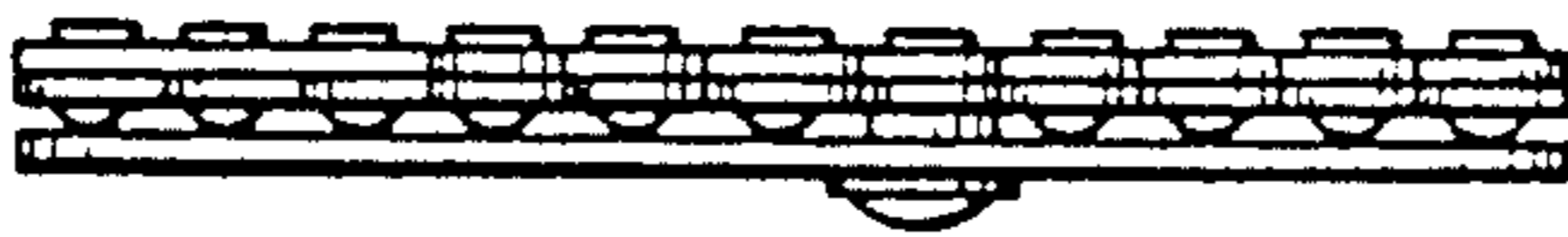

FIG-7



FIG-8

