

[54] TOY VEHICLE WITH CANOPY

[75] Inventor: Lawrence R. Harrod, Fort Wayne, Ind.

[73] Assignee: Kransco, San Francisco, Calif.

[**] Term: 14 Years

[21] Appl. No.: 379,532

[22] Filed: Jul. 13, 1989

[52] U.S. Cl. D21/134

[58] Field of Search D21/128, 134-137, D21/141; D12/98; 446/435, 465, 470

[56] References Cited

U.S. PATENT DOCUMENTS

D. 211,809	7/1968	Genin	D21/134
D. 238,801	2/1976	Goldfarb	D21/134
D. 292,425	10/1987	Lim	D21/136
D. 299,666	1/1989	Harrod	D21/134
D. 301,265	5/1989	Ishizawa	D21/136

OTHER PUBLICATIONS

Mongomery Ward Christmas Values, 1983, p. 137, "F" and E.

Hong Kong Toys, '88, p. 182.

Primary Examiner—Charles A. Rademaker

Assistant Examiner—R. Barkai

Attorney, Agent, or Firm—Kolisich, Hartwell, Dickinson

[57] CLAIM

The ornamental design for a toy vehicle with canopy, as shown and described.

DESCRIPTION

FIG. 1 is a left elevation of a toy vehicle with canopy, which is substantially a mirror image of the right elevation thereof, showing my new design;

FIG. 2 is a right elevation thereof;

FIG. 3 is a top plan view thereof;

FIG. 4 is a front elevation thereof;

FIG. 5 is a rear elevation thereof;

FIG. 6 is a bottom plan view thereof.

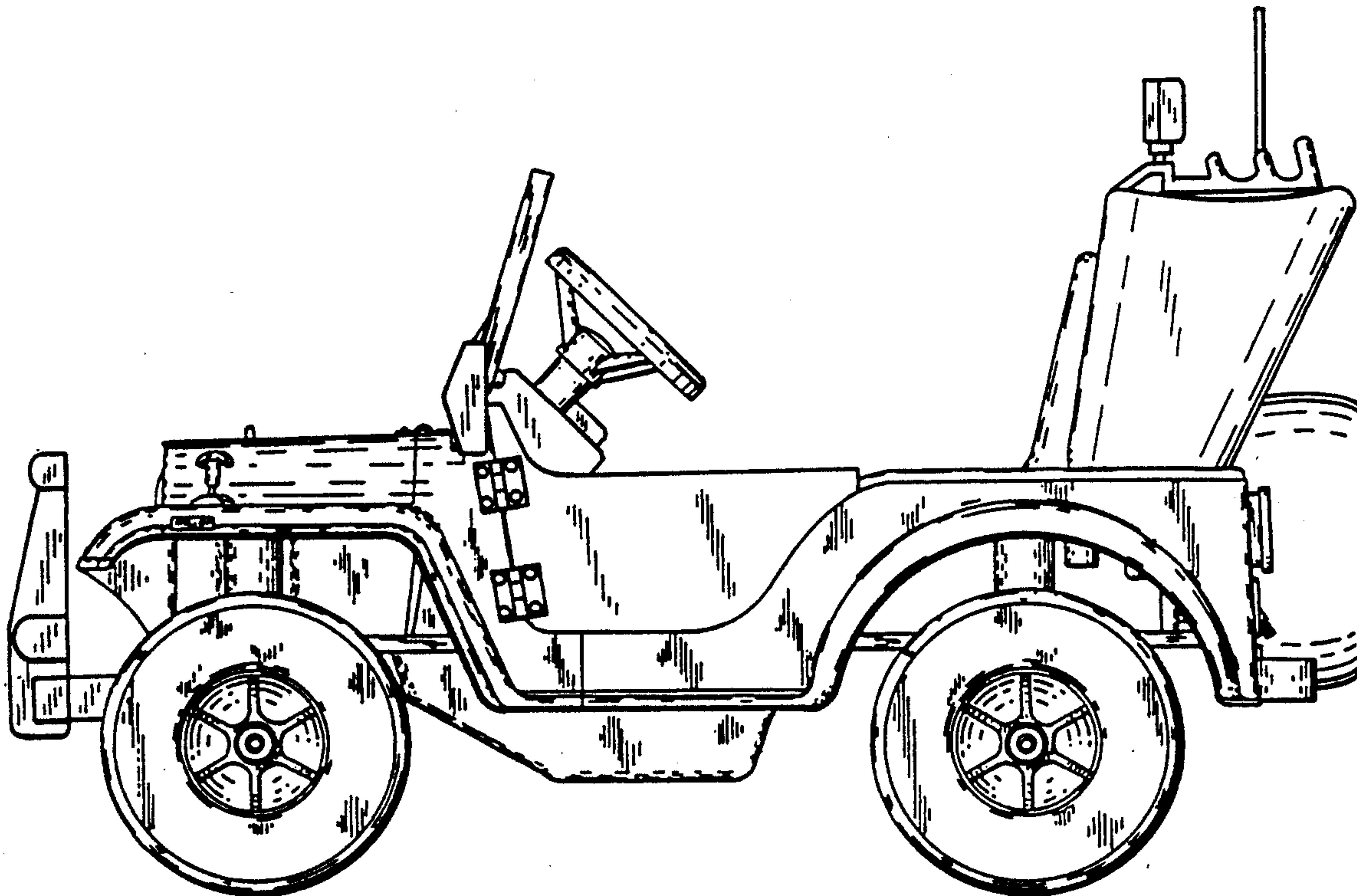

FIG. 1

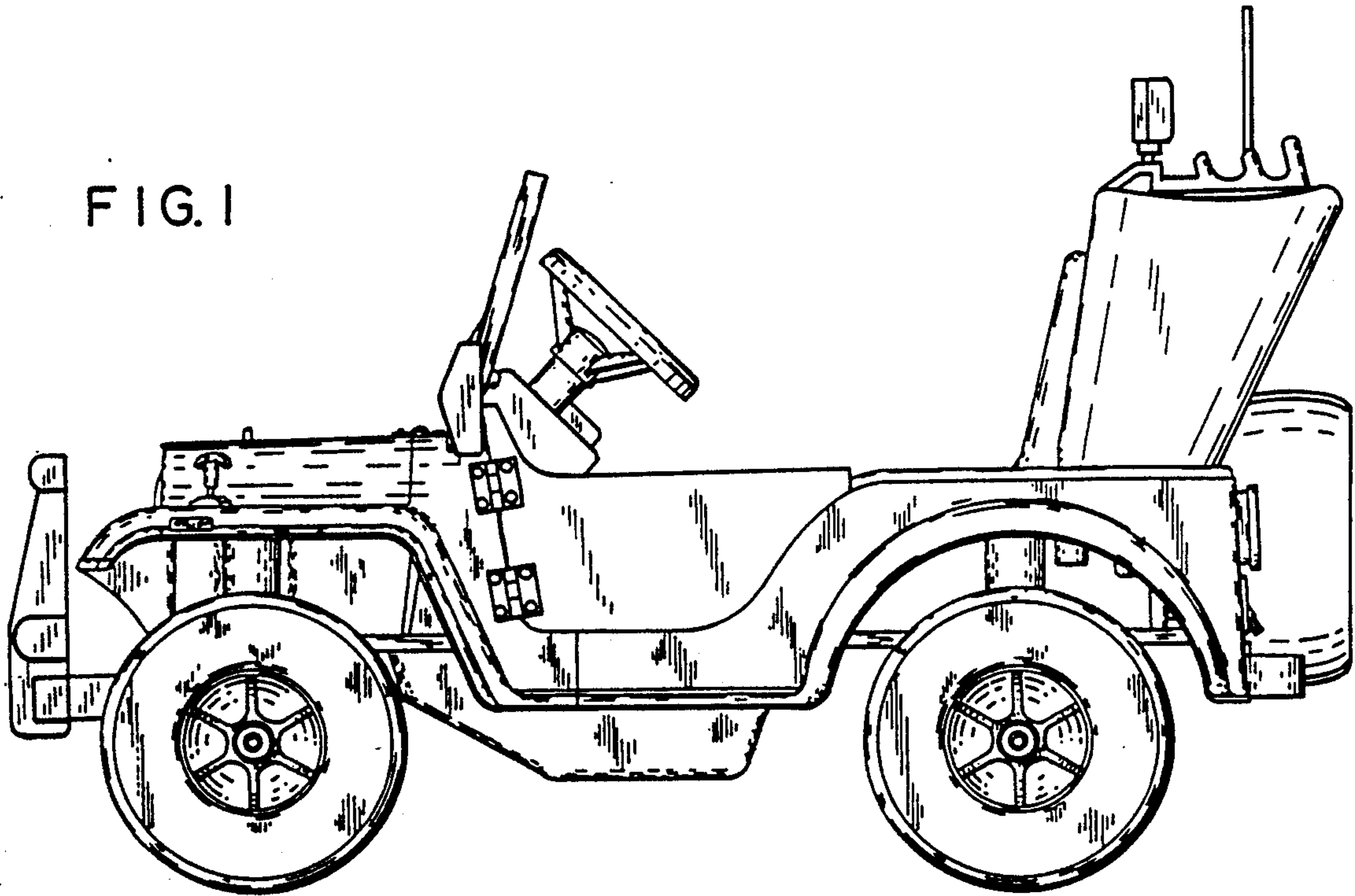

FIG. 2

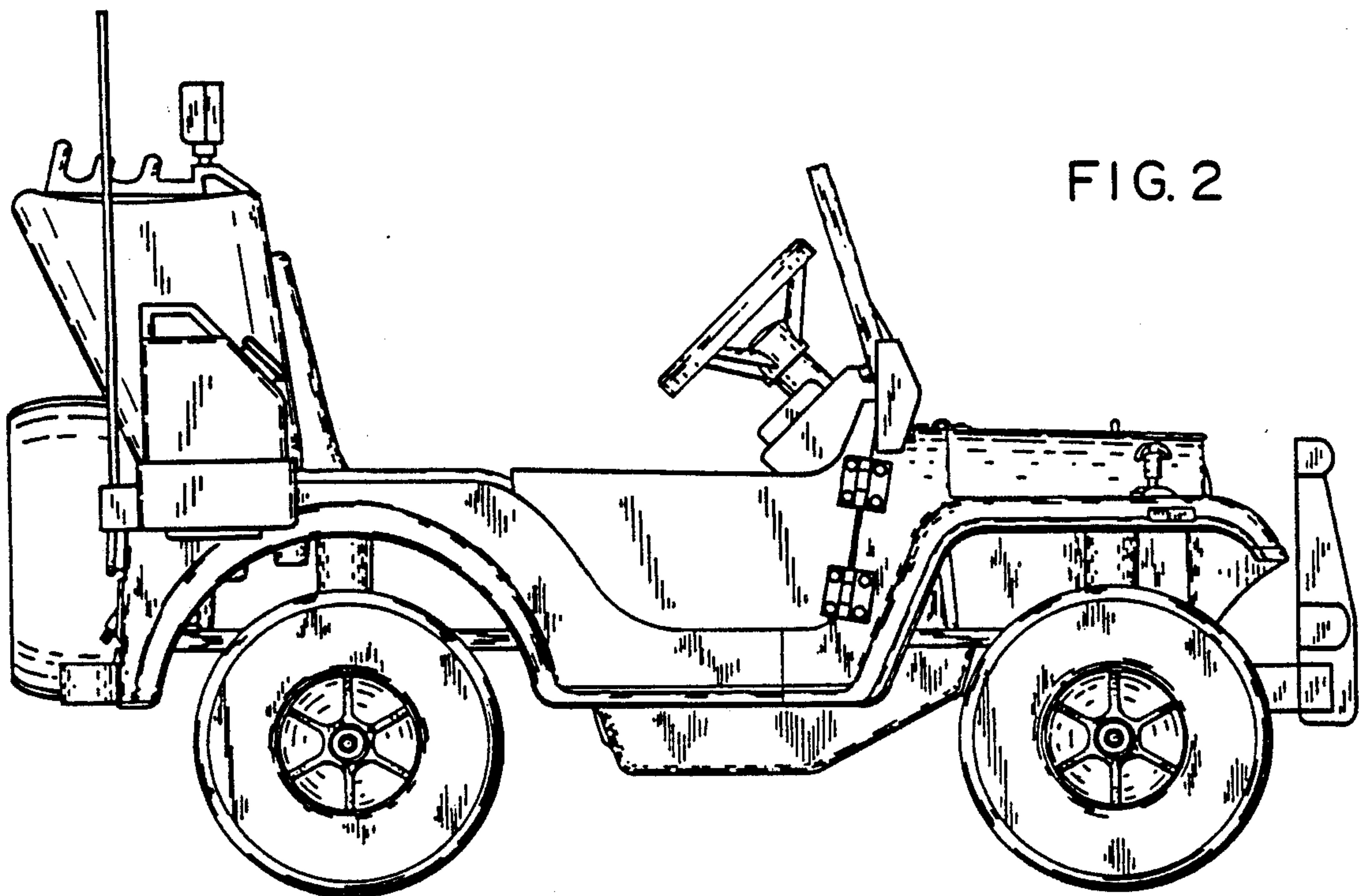

FIG. 3

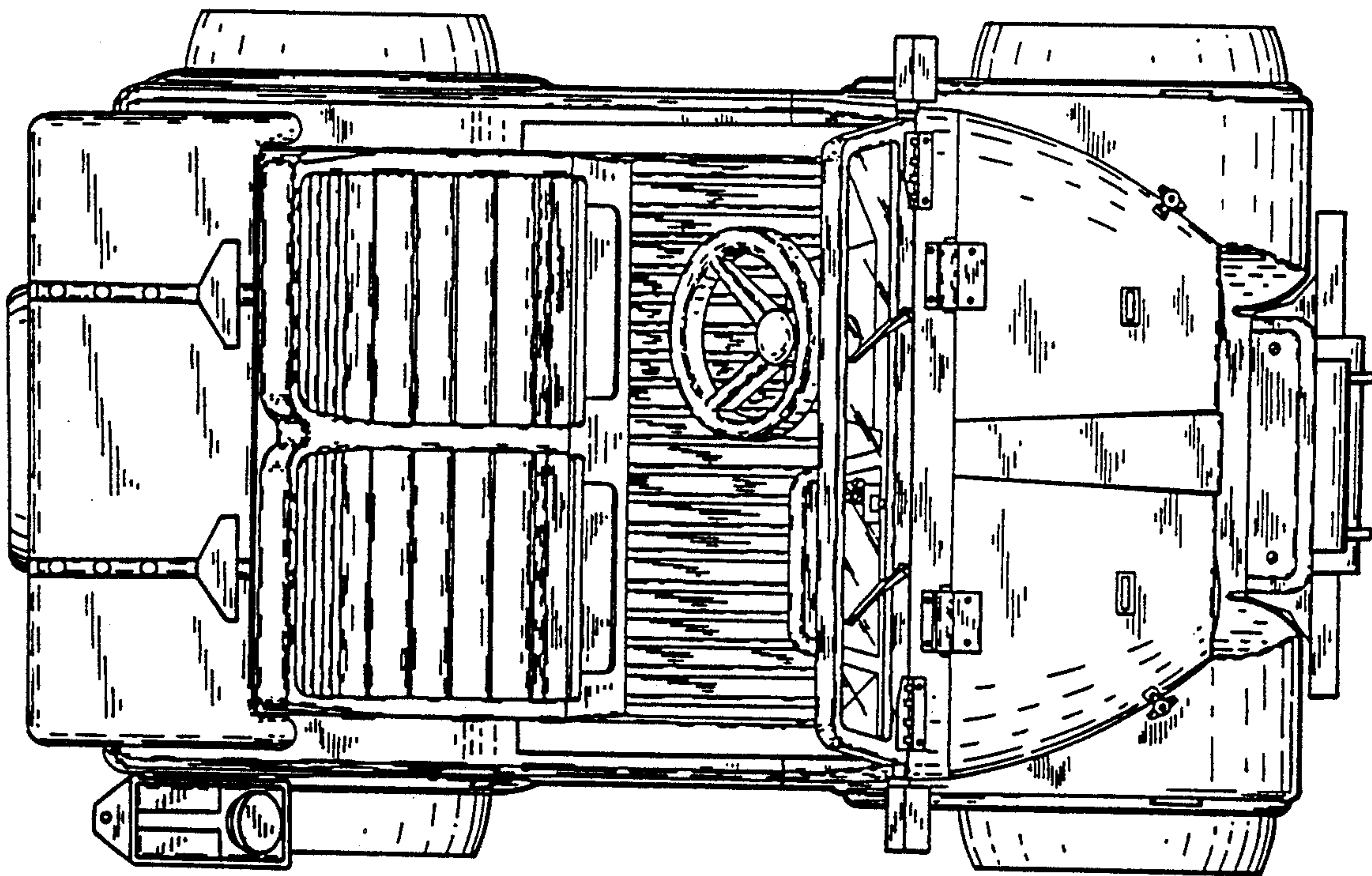

FIG. 6

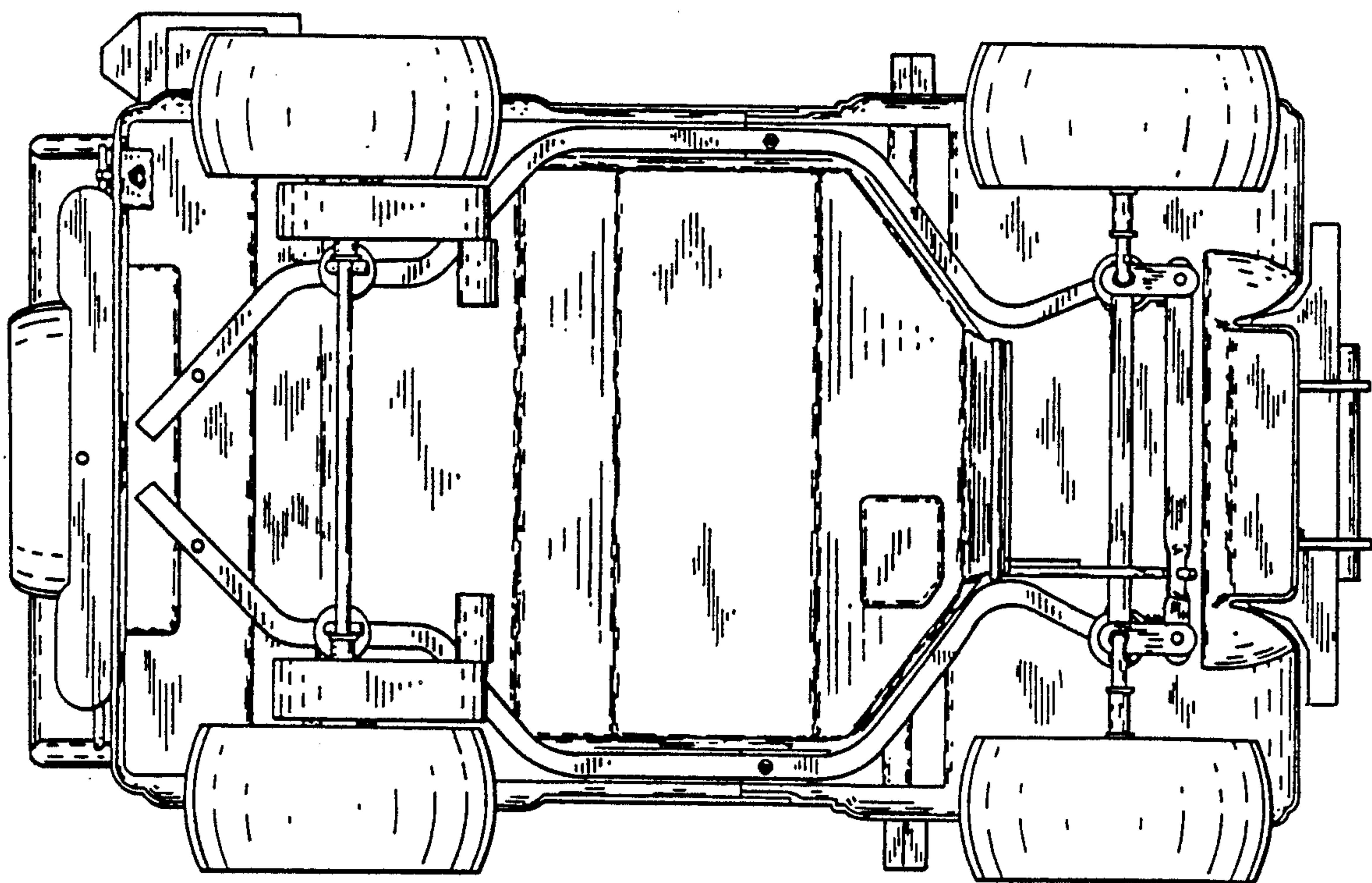

FIG. 4

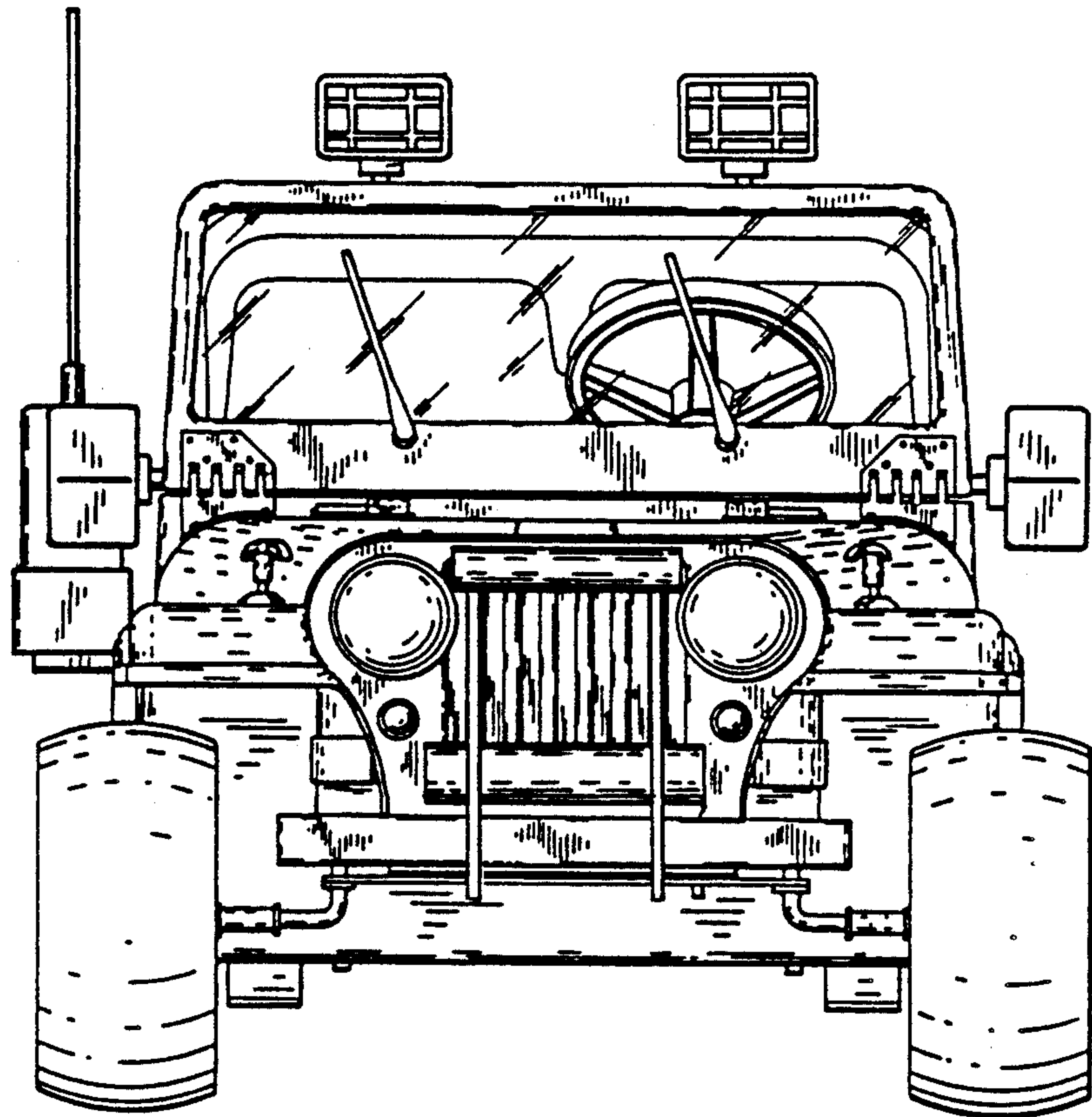

FIG. 5

