

[54] **BOAT TRAILER FENDER**

[76] **Inventor:** Byron L. Godbersen, Lake LaJune Estates, Ida Grove, Iowa 51445

[**] **Term:** 14 Years

[21] **Appl. No.:** 217,279

[22] **Filed:** Jul. 11, 1988

[52] **U.S. Cl.** D12/106; D12/184

[58] **Field of Search** D12/184, 101, 106; 280/847, 414.4

[56] **References Cited**

U.S. PATENT DOCUMENTS

D. 308,953 7/1990 Godbersen D12/106
4,097,085 6/1978 Nelson 280/847

Primary Examiner—James M. Gandy
Assistant Examiner—Melody Brown
Attorney, Agent, or Firm—Henderson & Sturm

[57] **CLAIM**

The ornamental design for a boat trailer fender, as shown.

DESCRIPTION

FIG. 1 is a perspective view of a boat trailer fender showing my new design;
FIG. 2 is a top plan view thereof;
FIG. 3 is a front elevational view thereof;
FIG. 4 is an end elevational view thereof, taken along the line 4—4 of FIG. 3;
FIG. 5 is a rear elevational view thereof; and
FIG. 6 is a bottom plan view thereof.

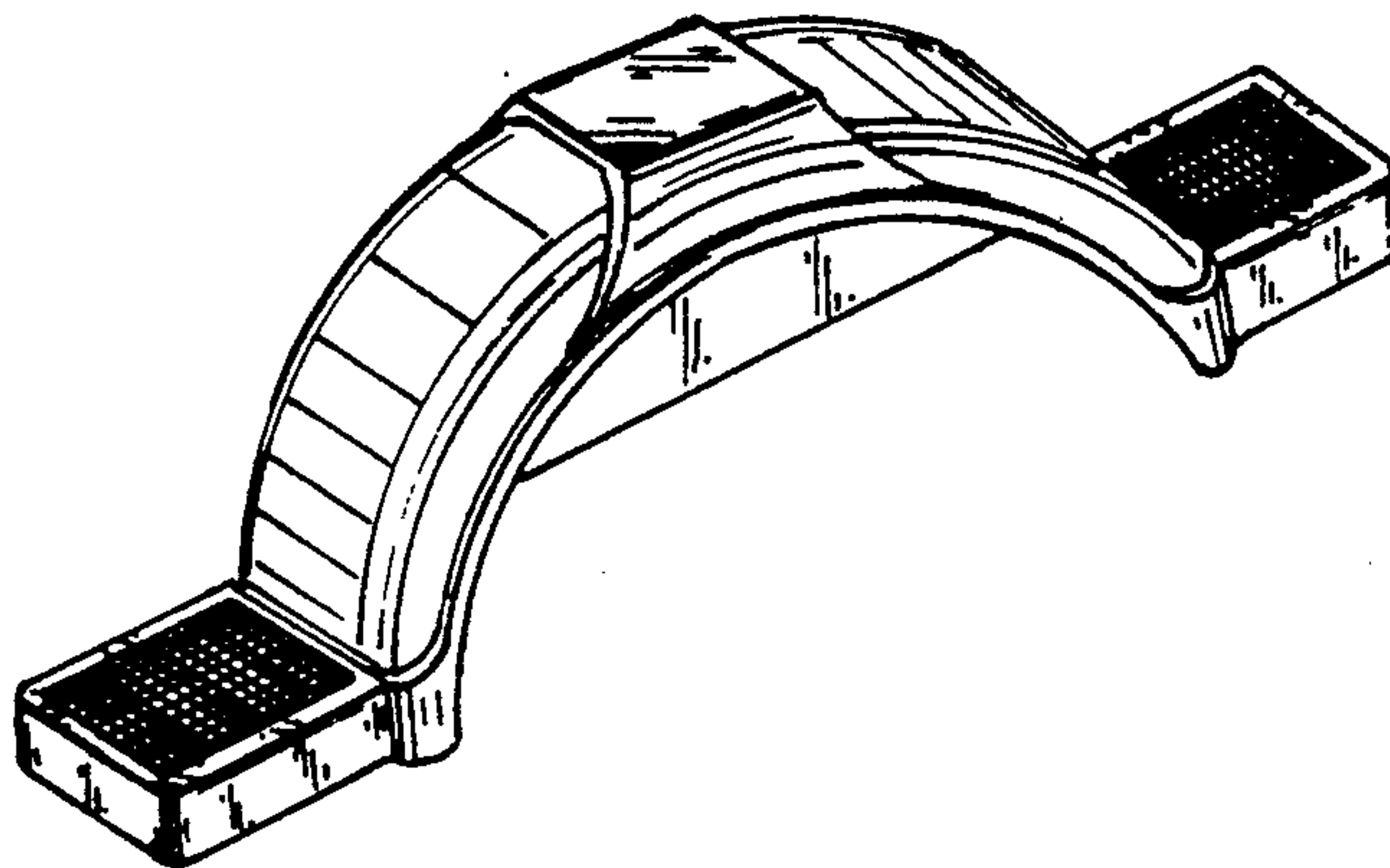

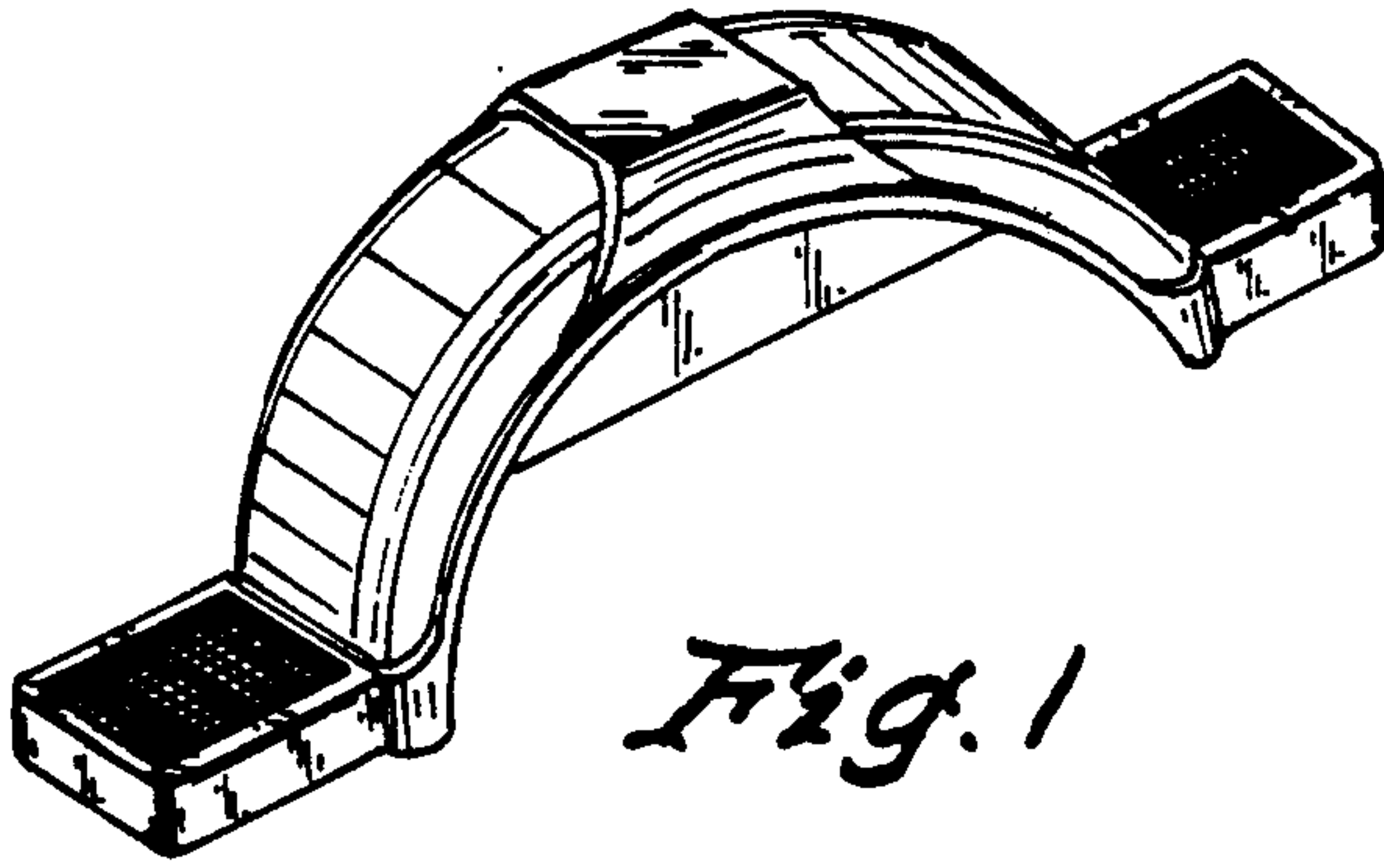

Fig. 1

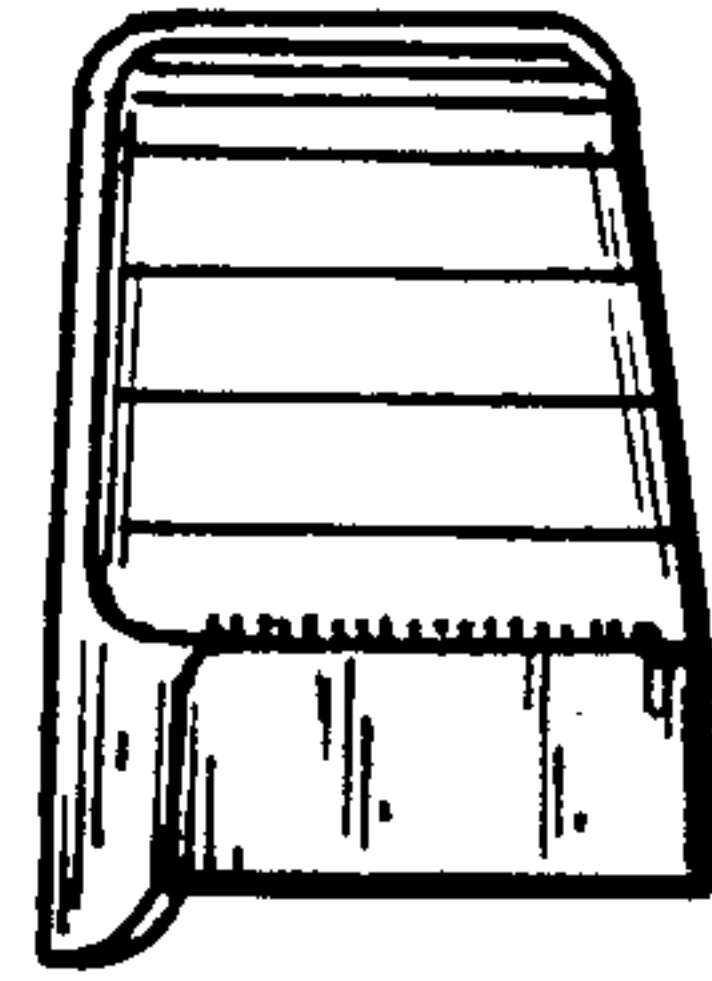

Fig. 4

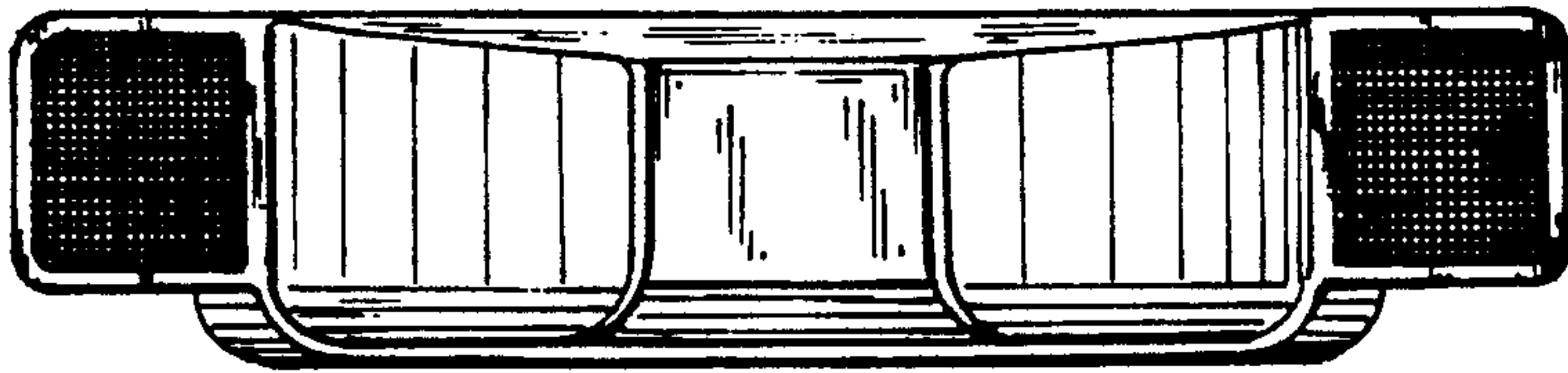

Fig. 2

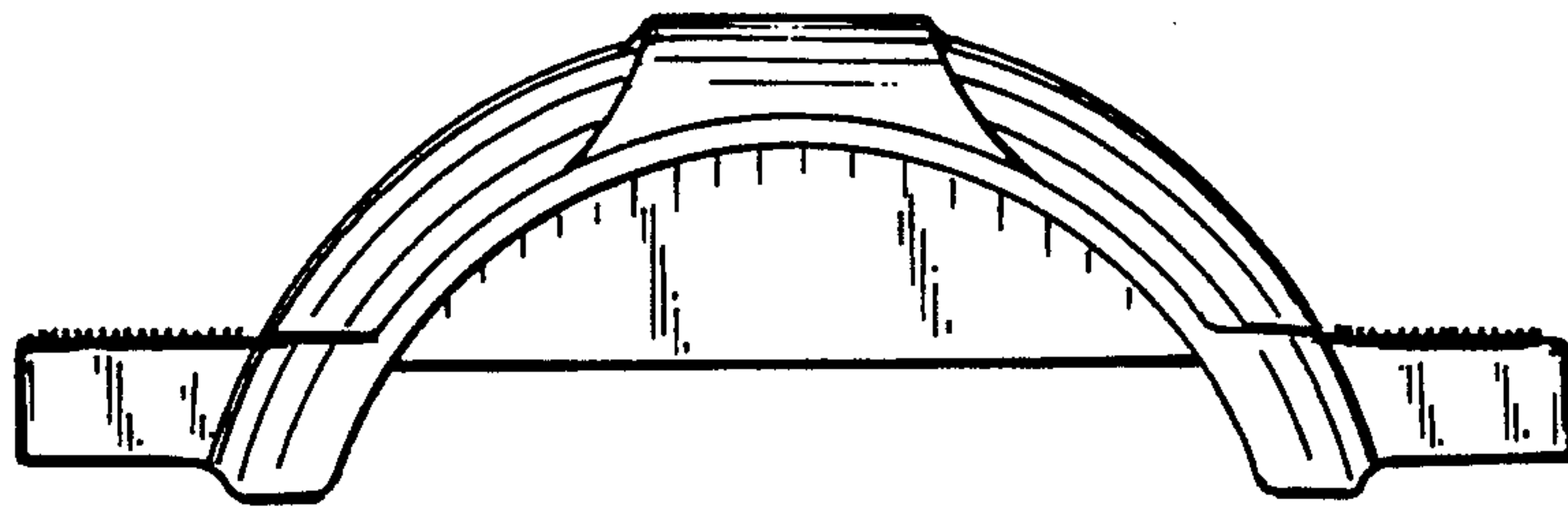

Fig. 3

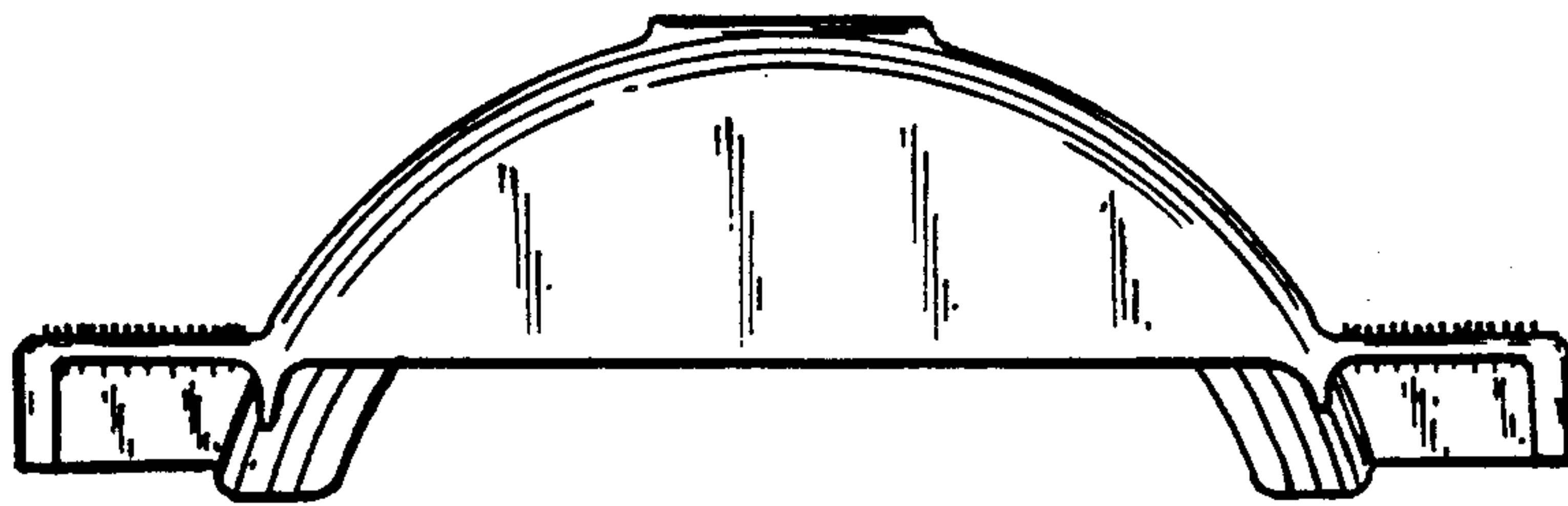

Fig. 5

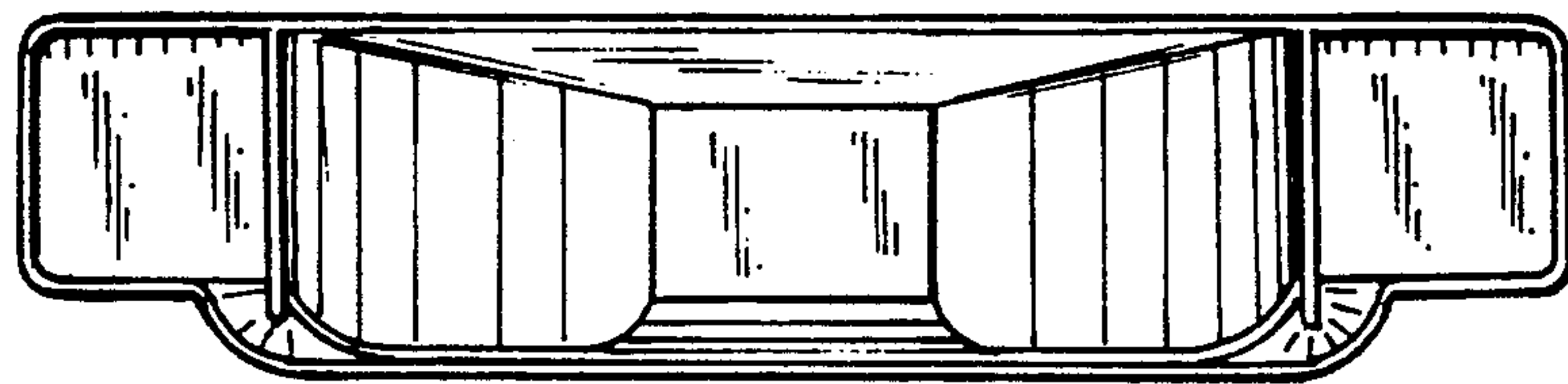

Fig. 6