

[54] REAR COMBINATION LAMP FOR AUTOMOBILE

[76] Inventor: Hiroshi Yamamoto, 6-24-11, Midorien, Izumi-ku, Yokohama-chi, Kanagawa-ken, Japan

[**] Term: 14 Years

[21] Appl. No.: 188,787

[22] Filed: Apr. 28, 1988

[52] U.S. Cl. D26/35

[58] Field of Search D26/28-36, D26/120, 121, 122; 362/61, 80, 80.1, 80.2, 82, 83, 83.2, 83.3, 362, 326, 329, 335-337, 339, 340

[56] References Cited

U.S. PATENT DOCUMENTS

- D. 285,122 8/1986 Fujita D26/35
- D. 293,134 12/1987 Mori D26/35

- D. 293,936 1/1988 Kawaoka D26/28
- D. 302,320 7/1989 Toyota D26/28
- 4,532,578 7/1985 Gaden et al. 362/80 X

Primary Examiner—Susan J. Lucas
Attorney, Agent, or Firm—Fleit, Jacobosn, Cohn, Price, Holman & Stern

[57] CLAIM

The ornamental design for rear combination lamp for automobile, as shown and described.

DESCRIPTION

FIG. 1 is a front perspective view of a rear combination lamp for an automobile embodying my new design; FIG. 2 is a front elevational view thereof; FIG. 3 is a right side view thereof; FIG. 4 is a left side view thereof; FIG. 5 is a rear elevational view thereof; FIG. 6 is a top plan view thereof; and FIG. 7 is a bottom plan view thereof.

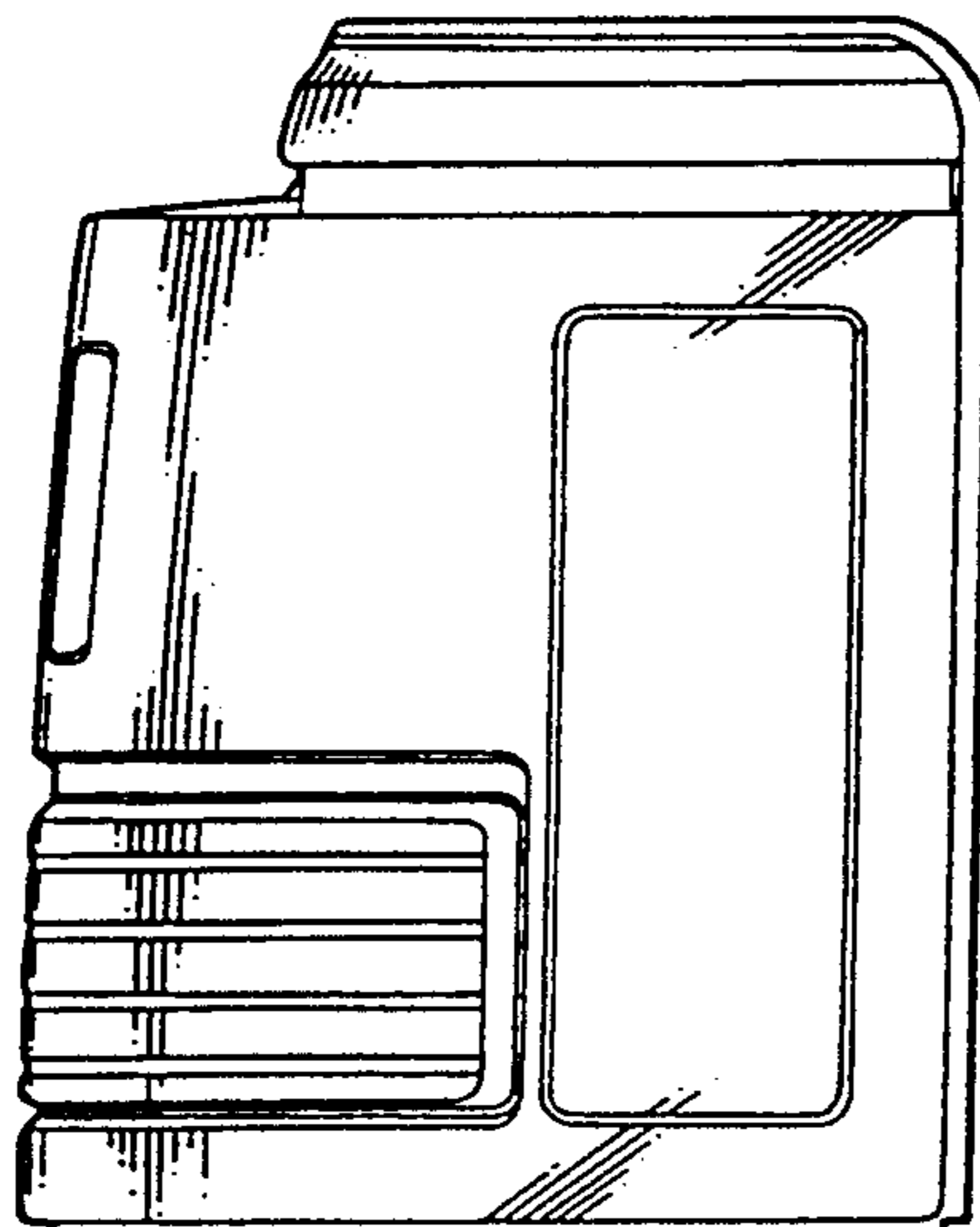
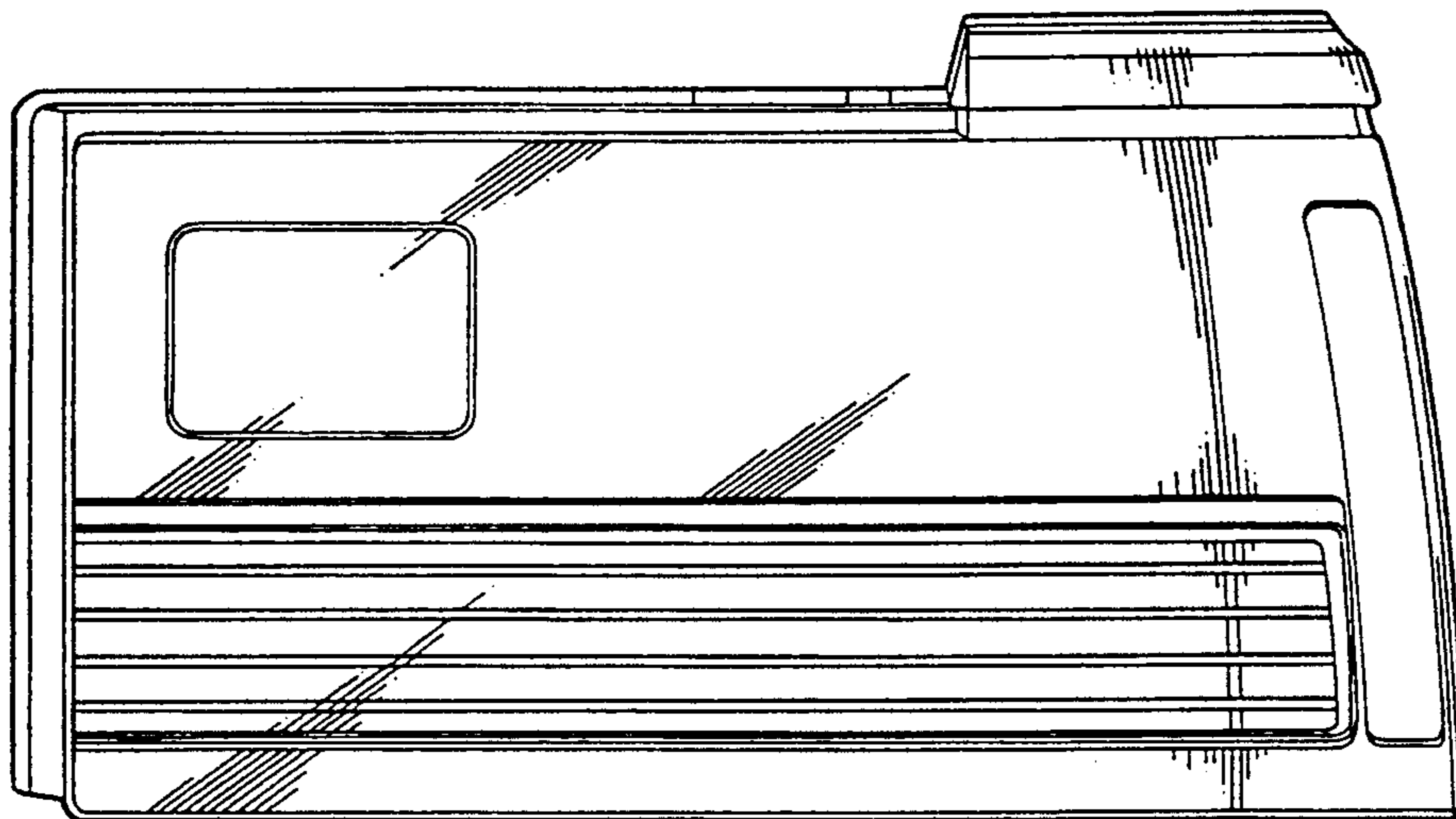

FIG. 1

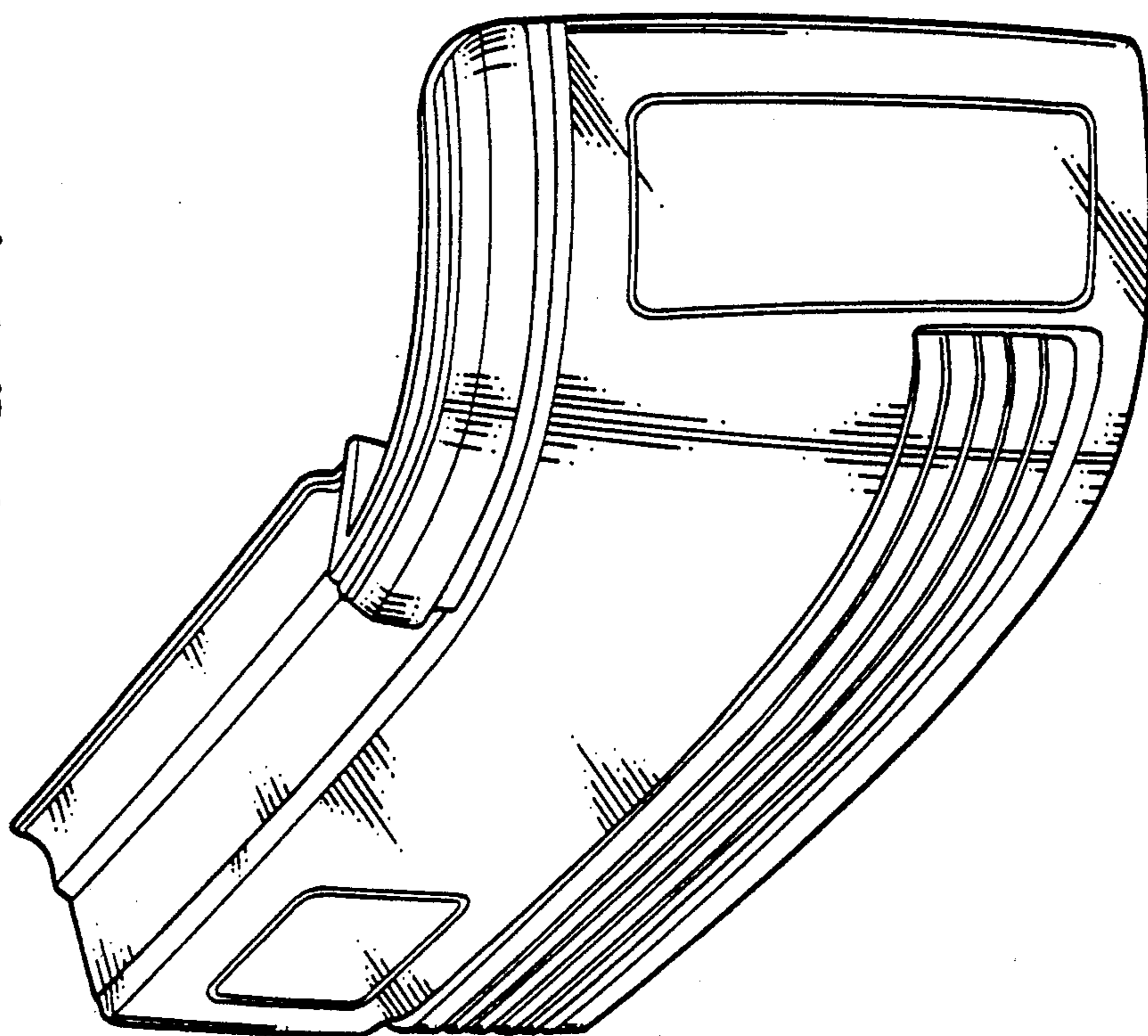

FIG. 3

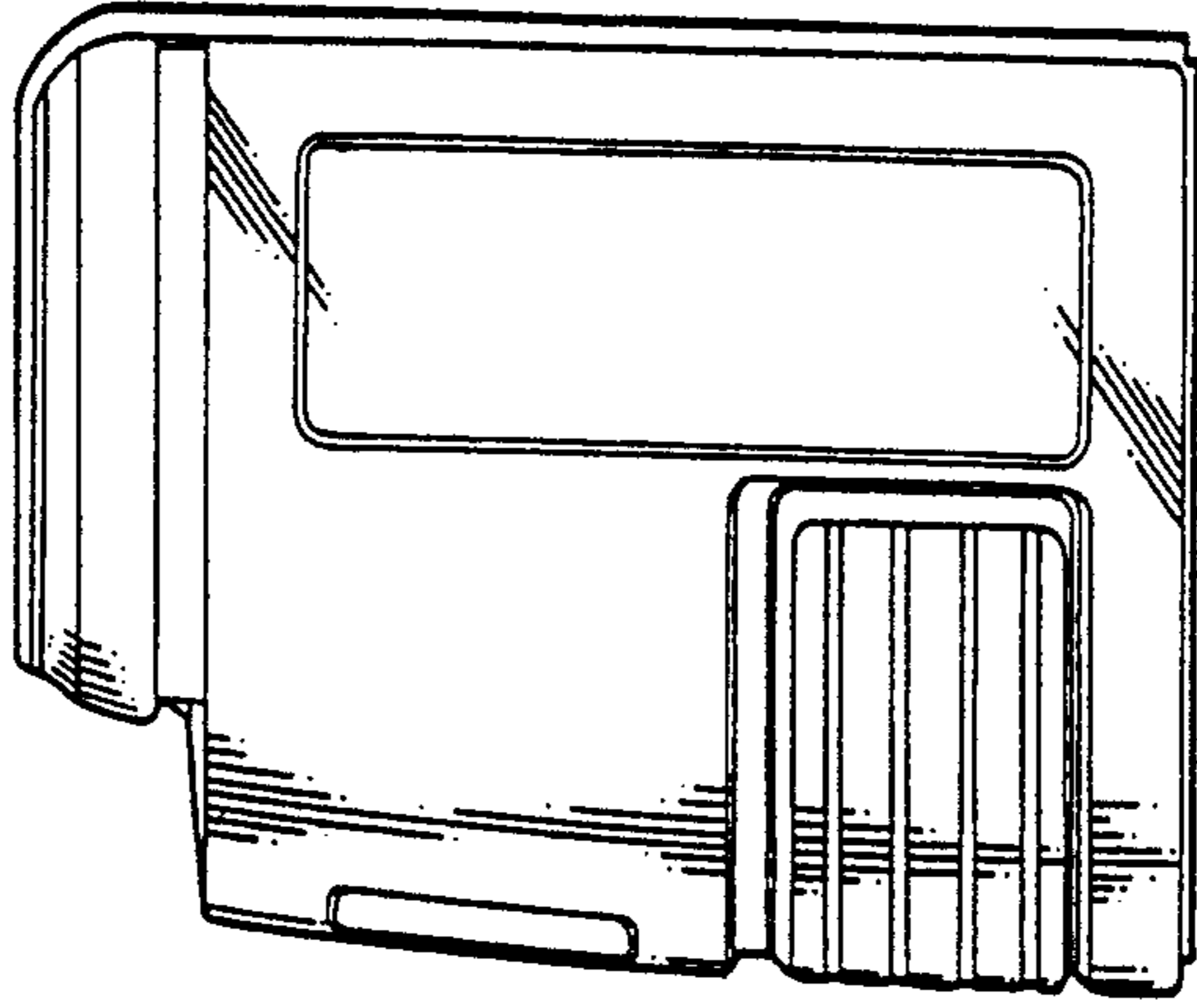

FIG. 2

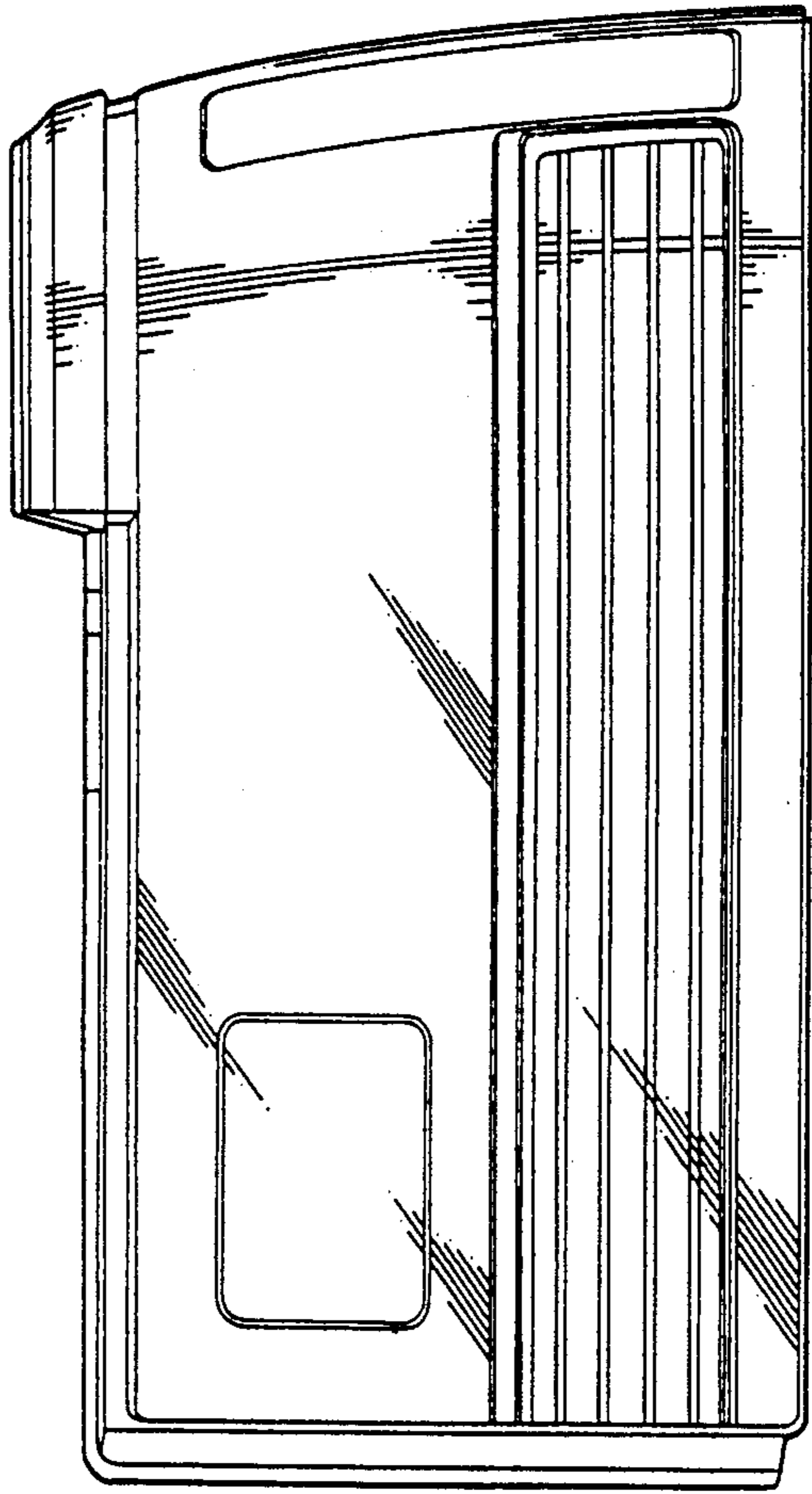

FIG. 5

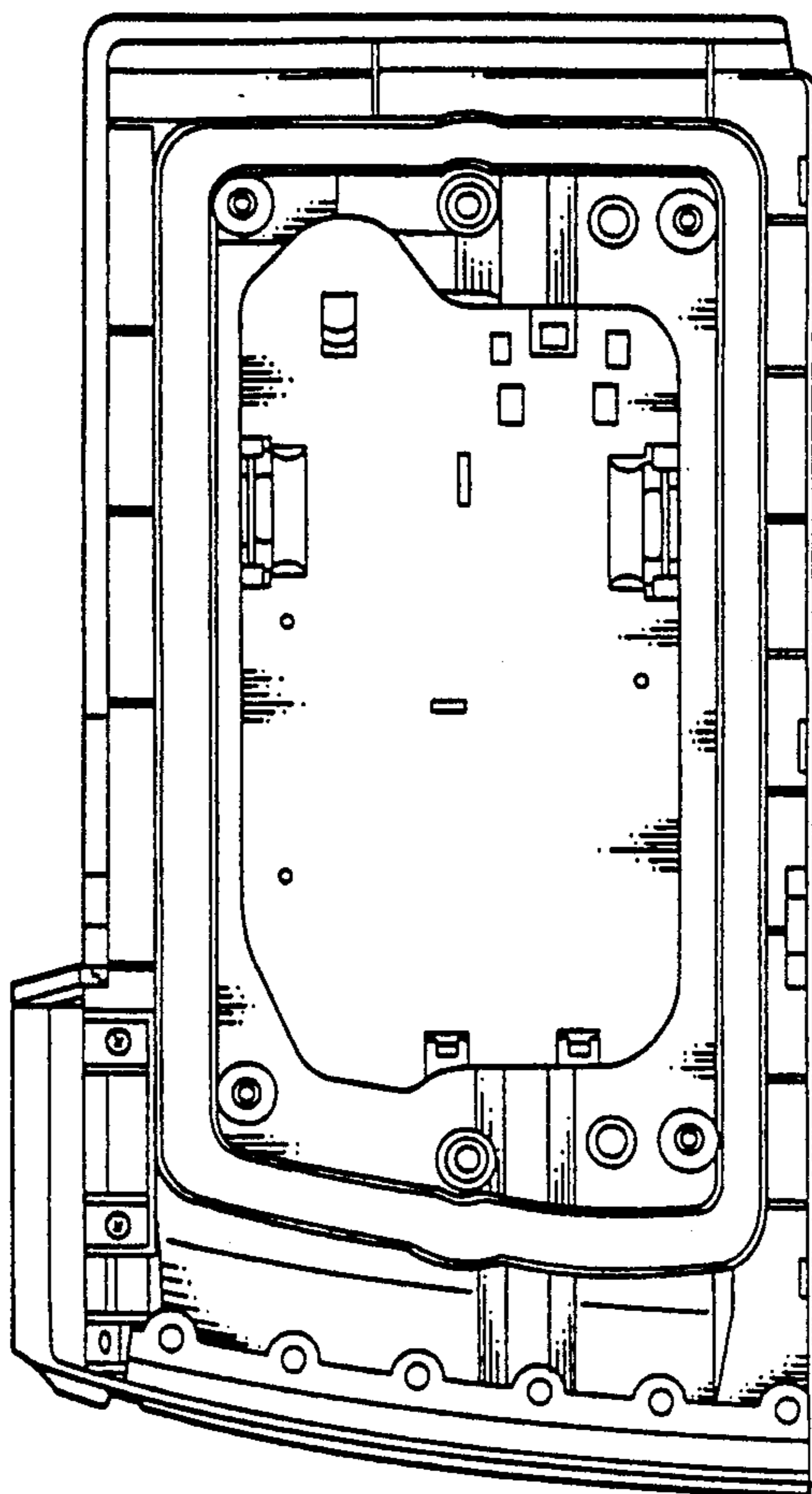

FIG. 4

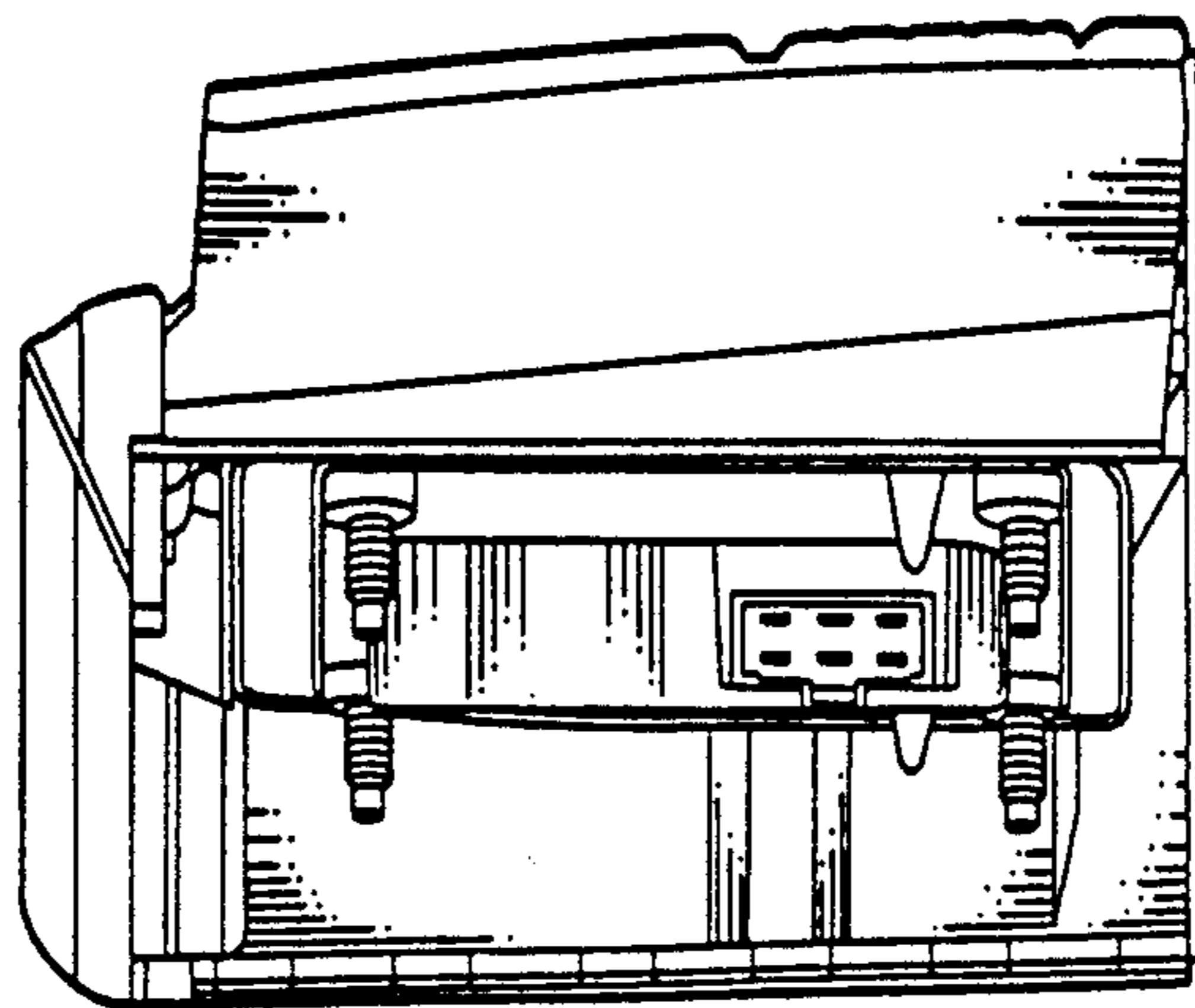

FIG. 6

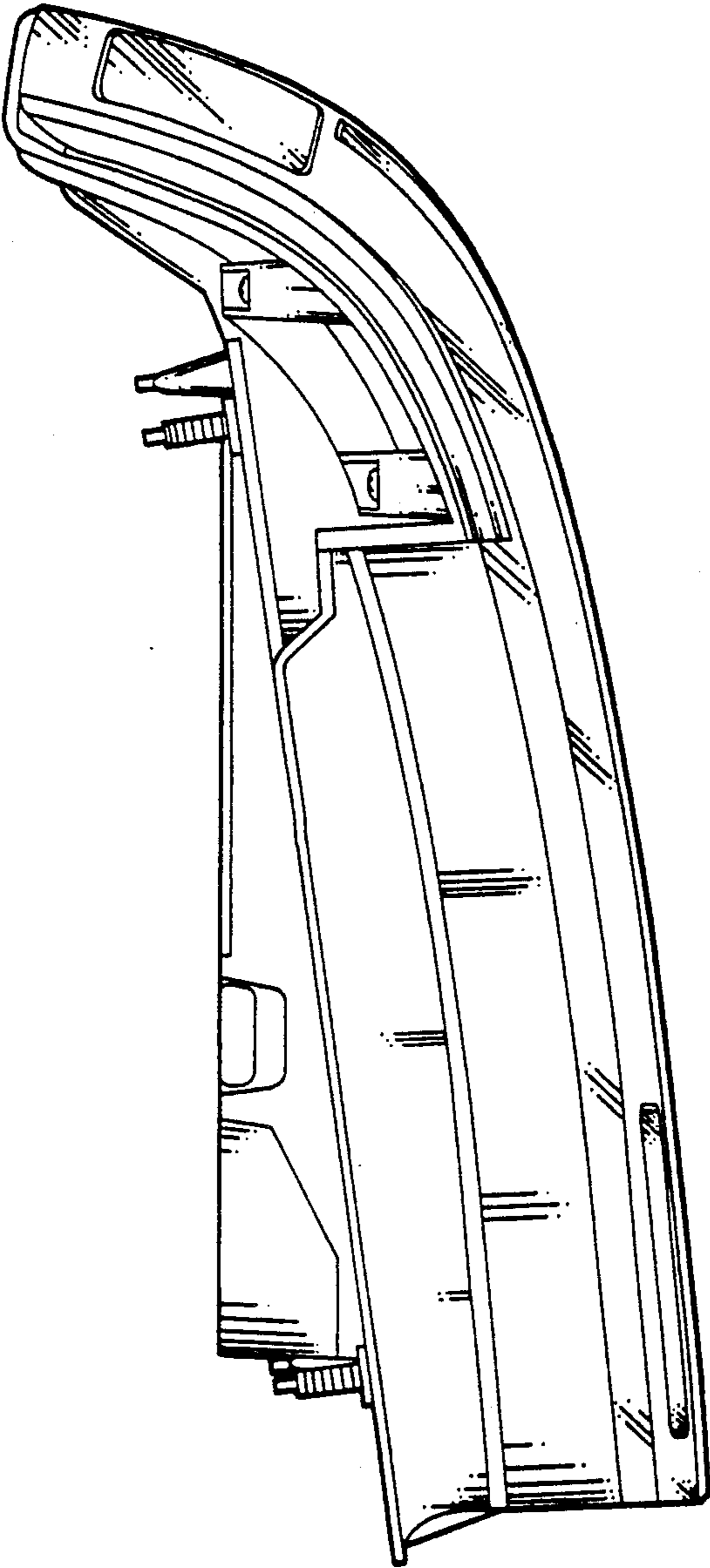

FIG. 7

