

[54] TOY VEHICLE

[75] Inventor: Martin M. Trossman, Orchard Park, N.Y.

[73] Assignee: The Quaker Oats Company, Chicago, Ill.

[**] Term: 14 Years

[21] Appl. No.: 256,295

[22] Filed: Oct. 11, 1988

[52] U.S. Cl. D21/140

[58] Field of Search D21/128, 134, 136, 140, D21/141, 59, 151; 446/465, 470, 428, 434, 451

[56] References Cited

U.S. PATENT DOCUMENTS

D. 141,154	5/1945	Wood	D21/151
D. 281,516	11/1985	Wong	D21/59
D. 309,643	7/1990	Picozza et al.	D21/128
4,430,827	2/1984	Rice et al.	446/465

FOREIGN PATENT DOCUMENTS

2468393 8/1981 France .

OTHER PUBLICATIONS

Hong Kong Toys '88, p. 765, 2nd row from top.

Primary Examiner—Charles A. Rademaker

Assistant Examiner—R. Barkai

Attorney, Agent, or Firm—Cumpston & Shaw

[57] CLAIM

The ornamental design for a toy vehicle, as shown and described.

DESCRIPTION

FIG. 1 is a top left front perspective view of a toy vehicle showing my new design;

FIG. 2 is a left side elevational view thereof;

FIG. 3 is a top plan view thereof;

FIG. 4 is a right side elevational view thereof;

FIG. 5 is a bottom plan view thereof;

FIG. 6 is a front elevational view thereof;

FIG. 7 is a rear elevational view thereof; and

FIG. 8 is a right side elevational view showing a portion of the top in open position.

The broken line showing of a toy figure in FIG. 8 is for illustrative purposes only and forms no part of the claimed design.

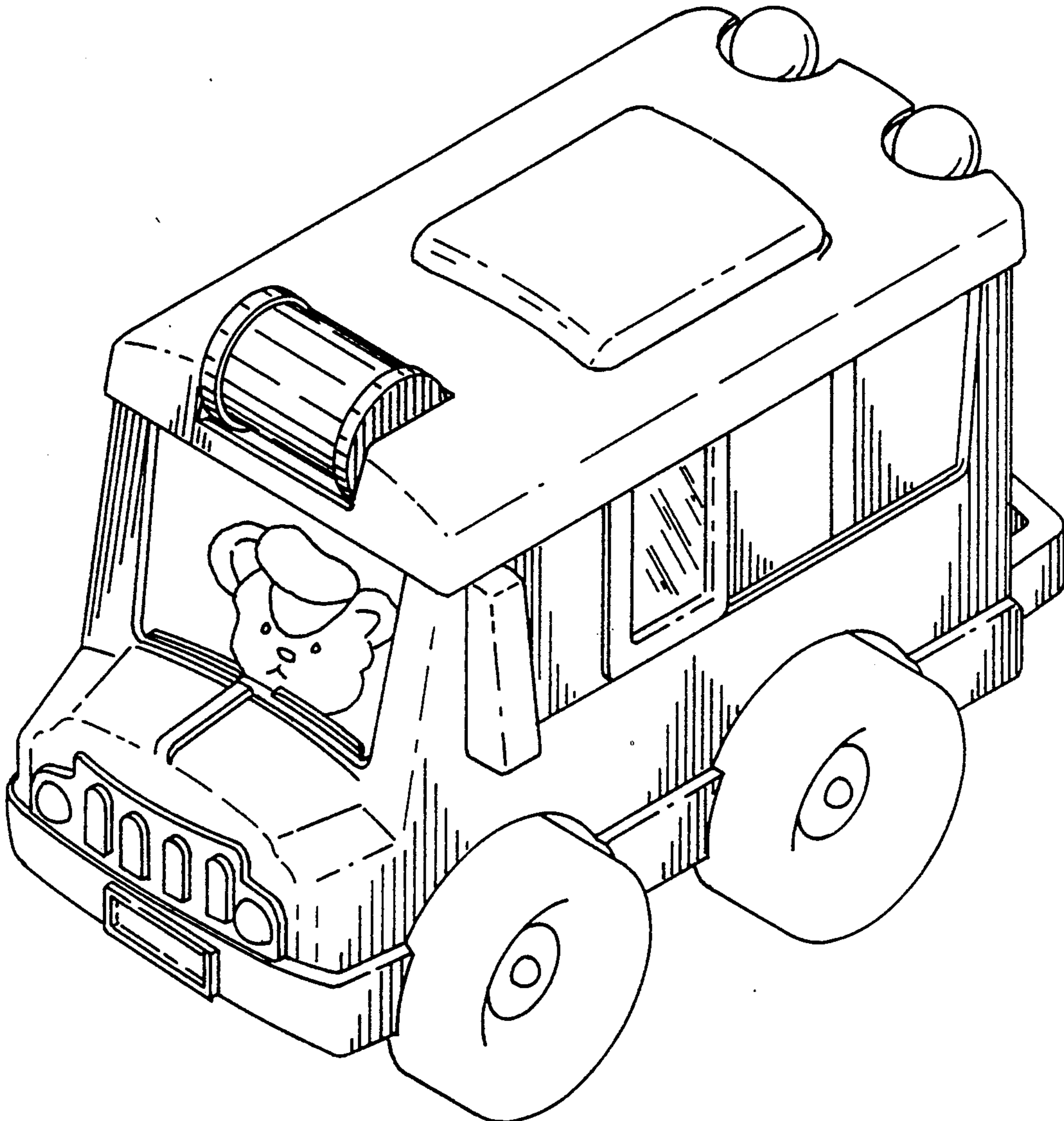

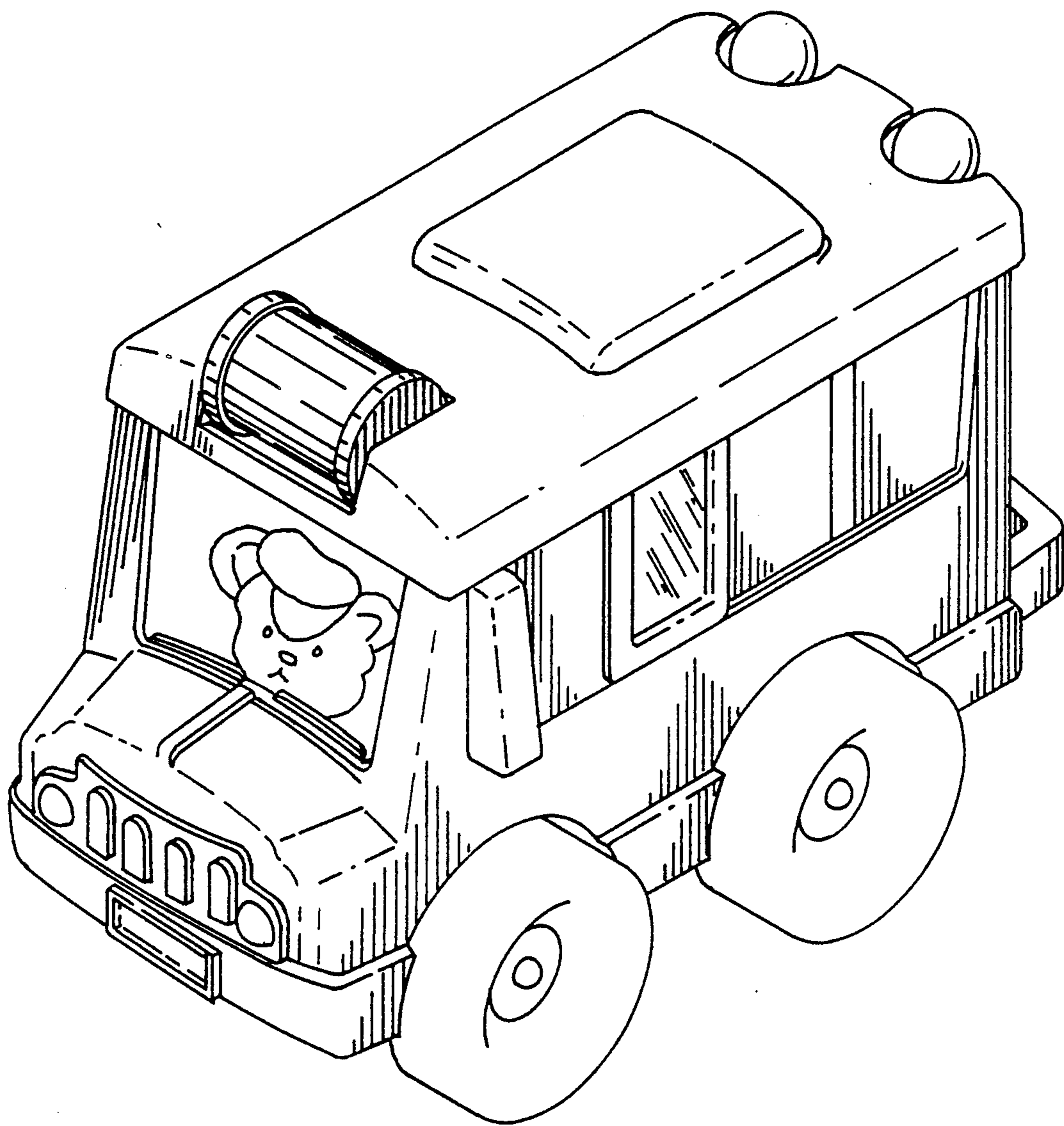

FIG. 1

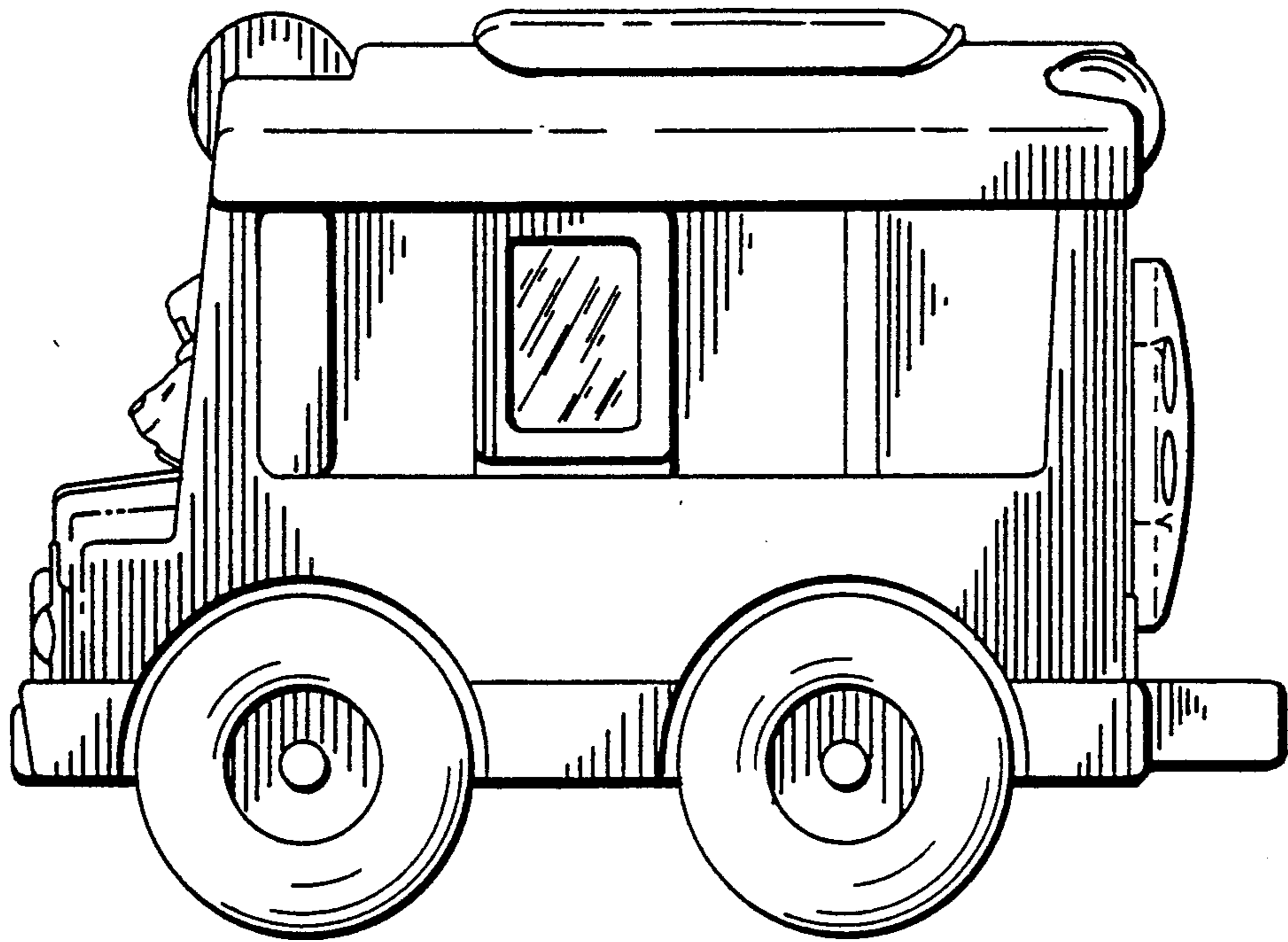

FIG. 2

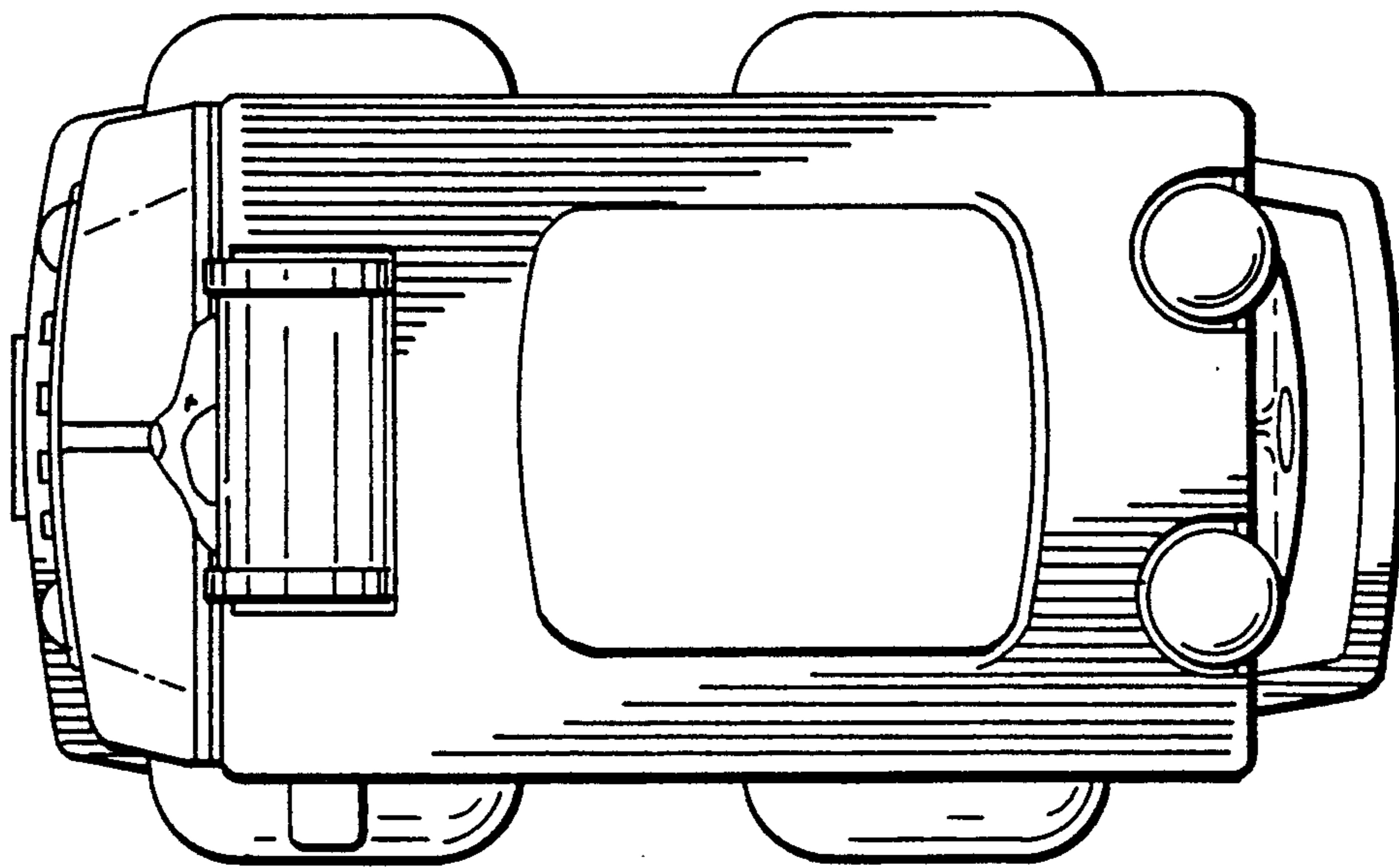

FIG. 3

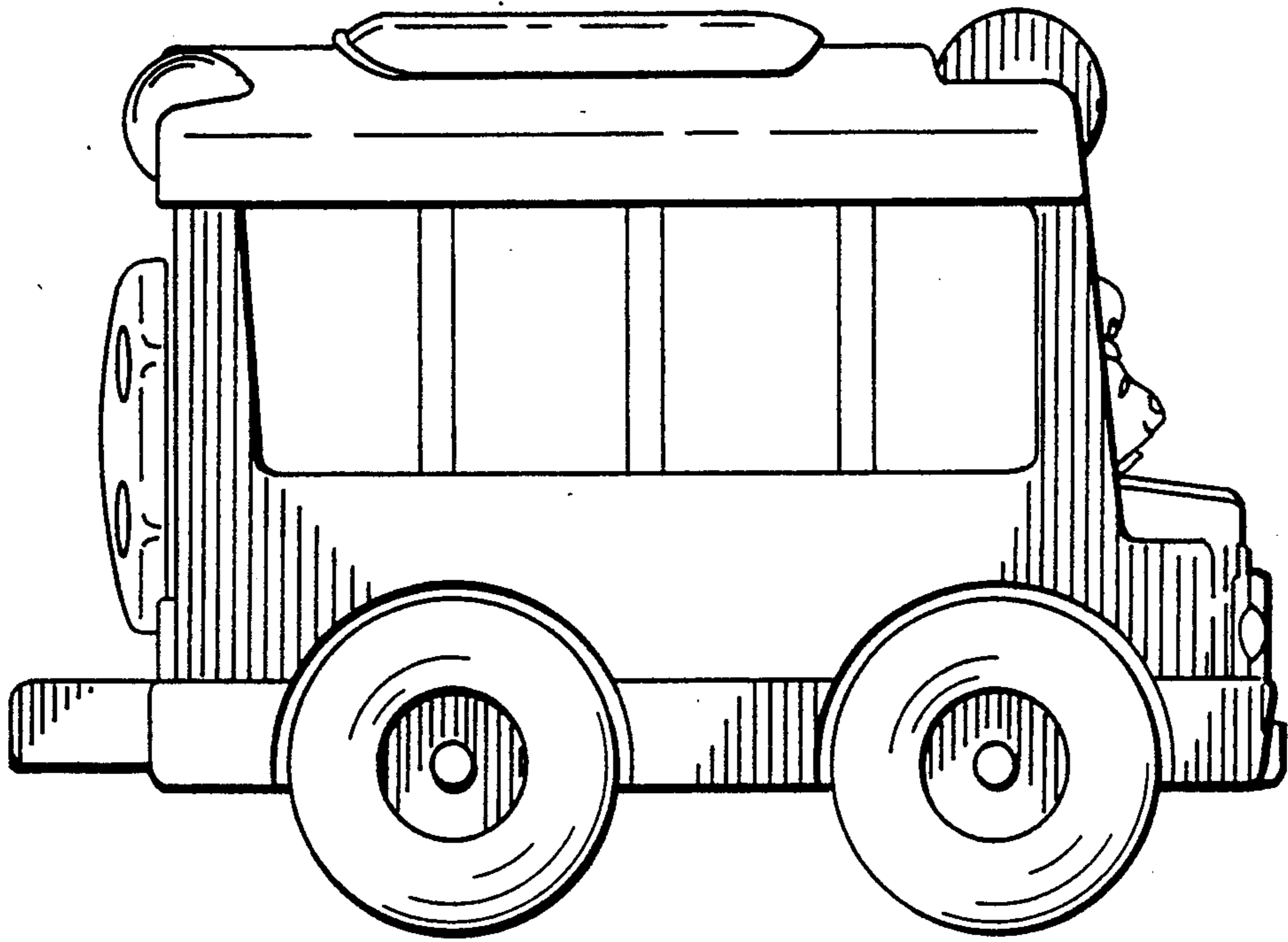

FIG. 4

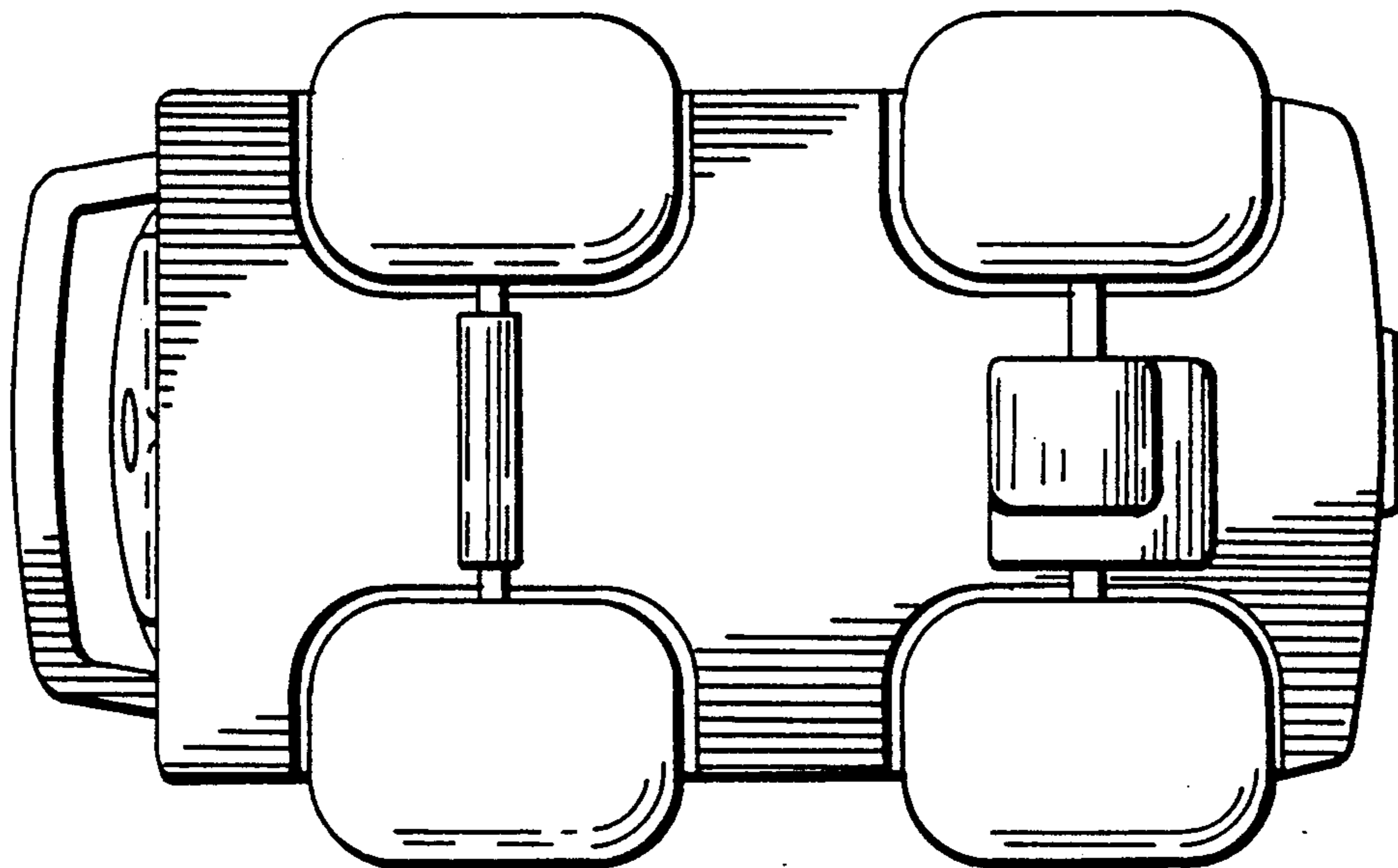

FIG. 5

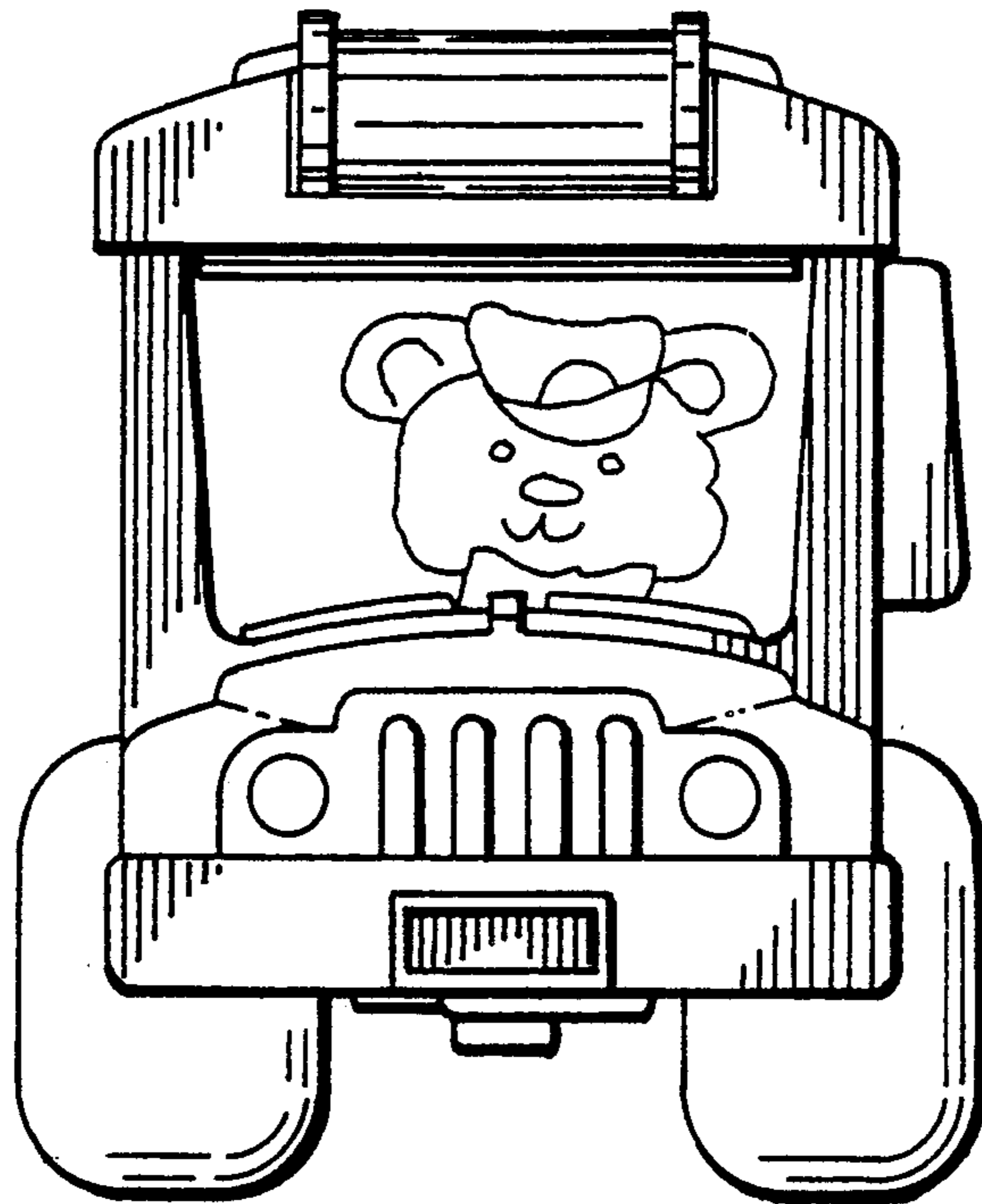

FIG. 6

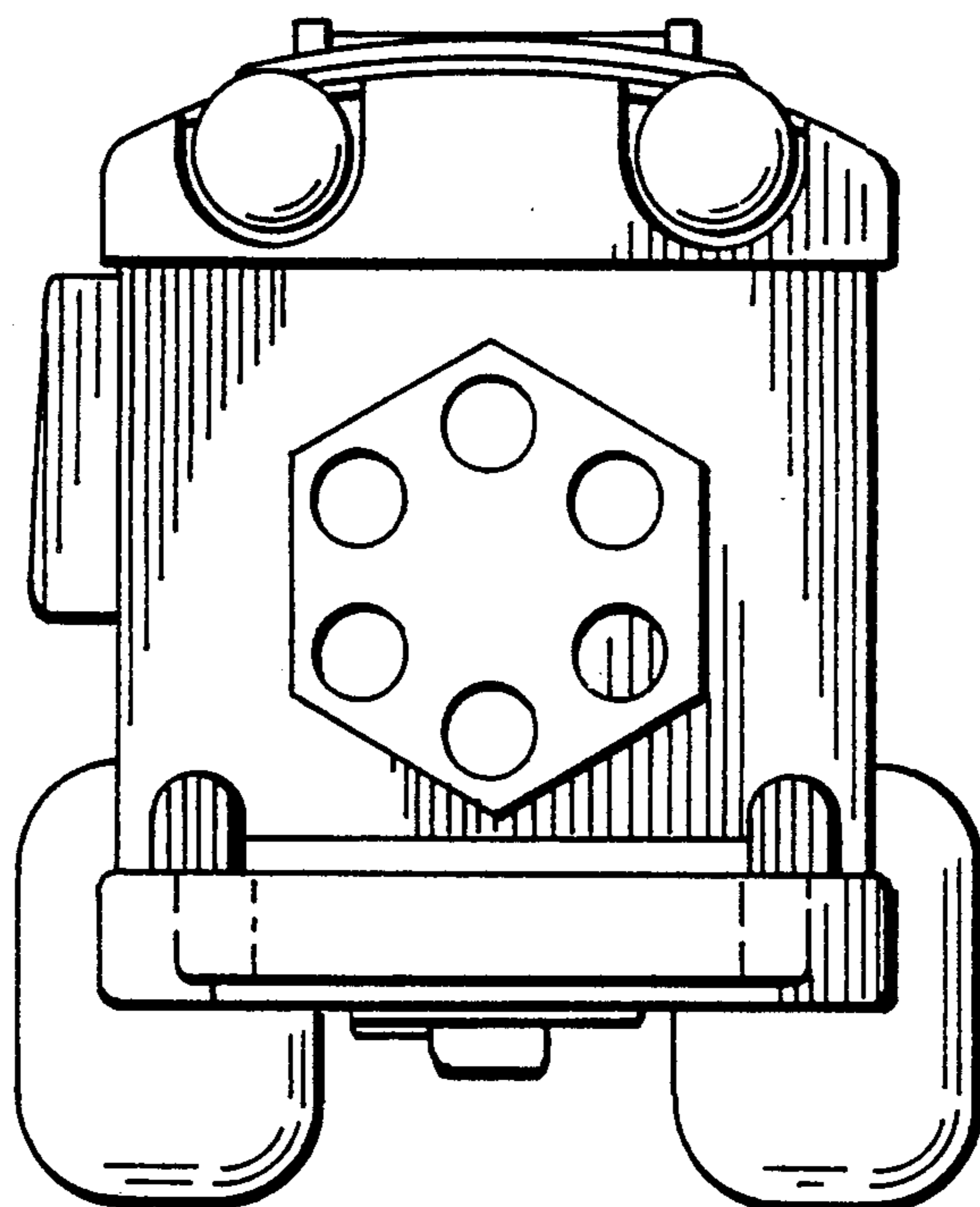

FIG. 7

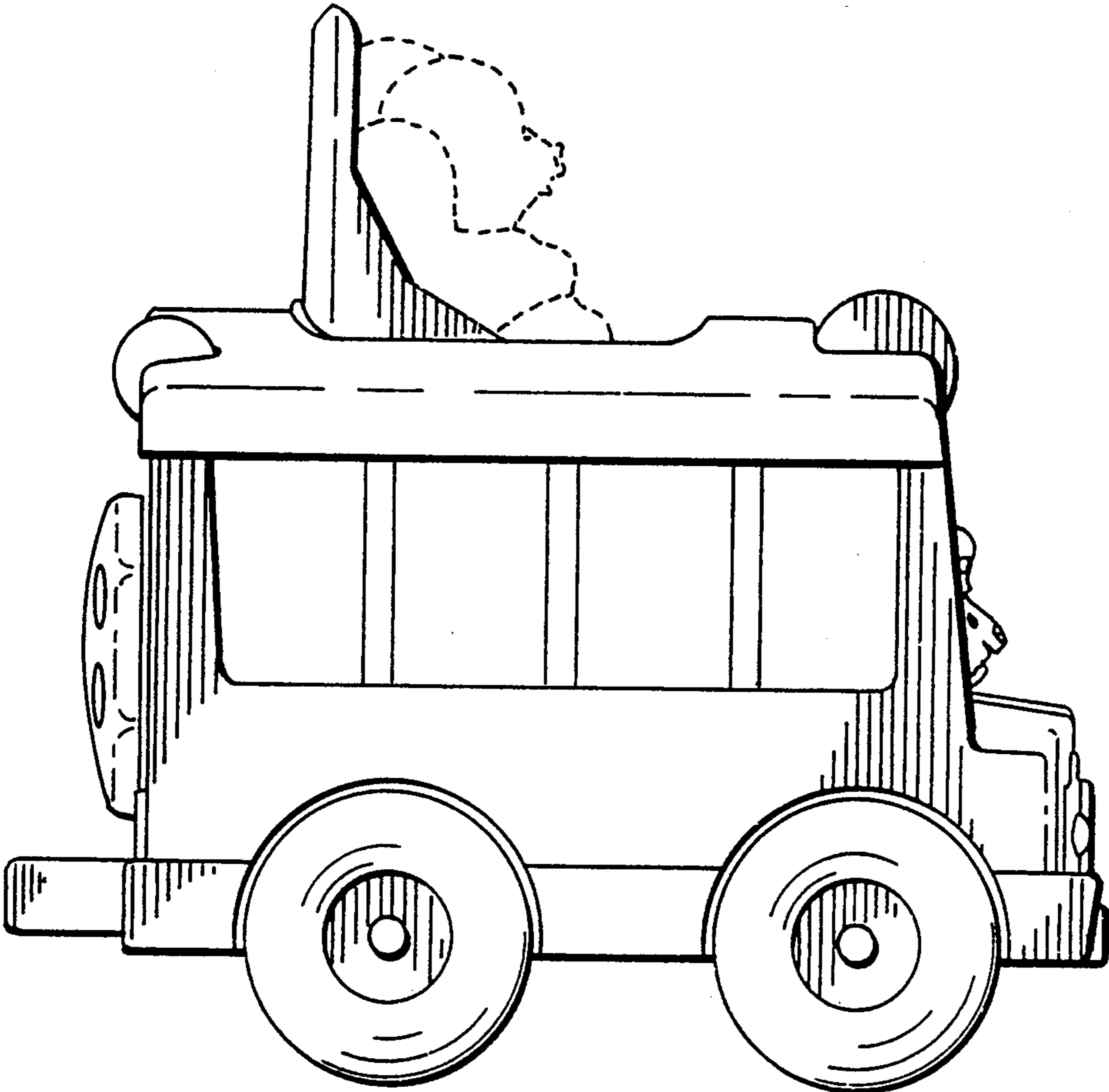

FIG. 8