

[54] **GAS TANK VENT FOR BOATS**
 [75] **Inventor:** Warwick M. Whitley, II, Panama City, Fla.
 [73] **Assignee:** Attwood Corporation, Lowell, Mich.
 [**] **Term:** 14 Years
 [21] **Appl. No.:** 214,652
 [22] **Filed:** Jul. 1, 1988
 [52] **U.S. Cl.** D12/317; D23/260
 [58] **Field of Search** 137/97, 384.2; 220/371-376, 88; 440/89; D23/230-235, 260-265; D12/317

4,671,773 6/1987 Friedle et al. .
 4,677,929 7/1987 Harris .
 4,706,840 11/1987 Thompson .

OTHER PUBLICATIONS

P. 45, Attwood Product Catalog 1987/88.
 P. 29, Gil Marine Catalog (not dated).
 P. F4, Perko Catalog, 1981.
 P. 26, Wilcox-Crittenden Catalog 516 (not dated).

Primary Examiner—James R. Largen
Assistant Examiner—Demetrius Reynolds
Attorney, Agent, or Firm—Price, Heneveld, Cooper, DeWitt & Litton

[56] **References Cited**
U.S. PATENT DOCUMENTS

D. 232,360	8/1974	Watts	D23/247
D. 245,255	8/1977	Porter	D23/260
D. 245,333	8/1977	Porter et al.	D23/260
D. 266,923	11/1982	Parks et al.	D12/317
D. 271,682	12/1983	MacDougall	D12/317
924,587	6/1909	Sharp	220/367
1,350,109	8/1920	Nystrom	220/373
1,384,369	7/1921	Wiesener	137/384.2
2,006,027	6/1935	Moore	137/384.2
2,262,018	11/1941	Lighton	220/367
3,021,029	2/1962	McKimlay	220/363
3,103,870	9/1963	Steiner	114/211
4,392,584	7/1983	Bauer	220/374

[57] **CLAIM**

The ornamental design for a gas tank vent for boats, as shown and described.

DESCRIPTION

FIG. 1 is a perspective view taken from the top, front and right side of a gas tank vent for boats showing my new design;
 FIG. 2 is a perspective view taken from the bottom, front and left side thereof.
 FIG. 3 is a top plan view thereof;
 FIG. 4 is a right side elevational view thereof, the left side being a mirror of the right side shown.
 FIG. 5 is a front elevational view thereof;
 FIG. 6 is a bottom plan view thereof; and
 FIG. 7 is a rear elevational view thereof.

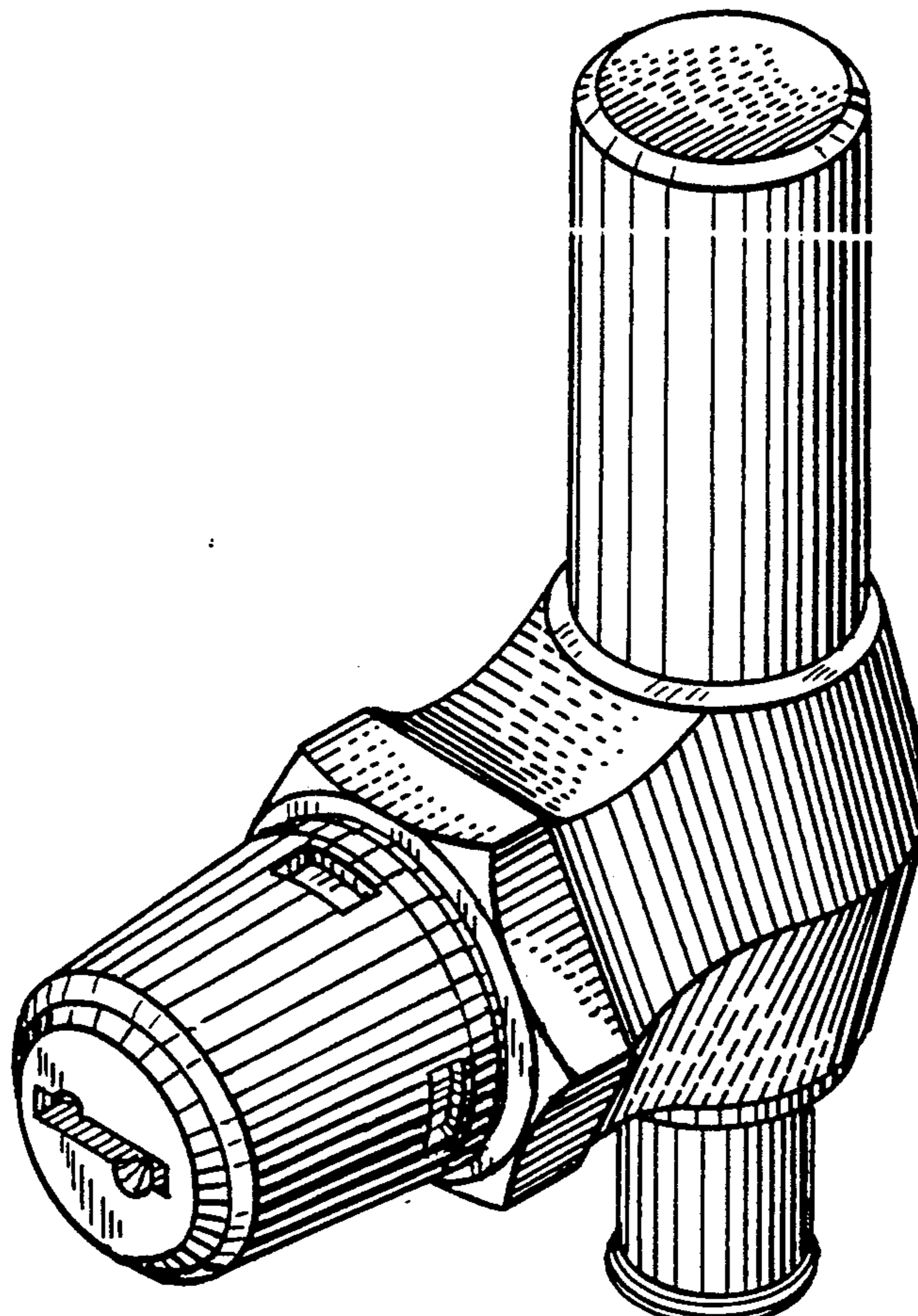

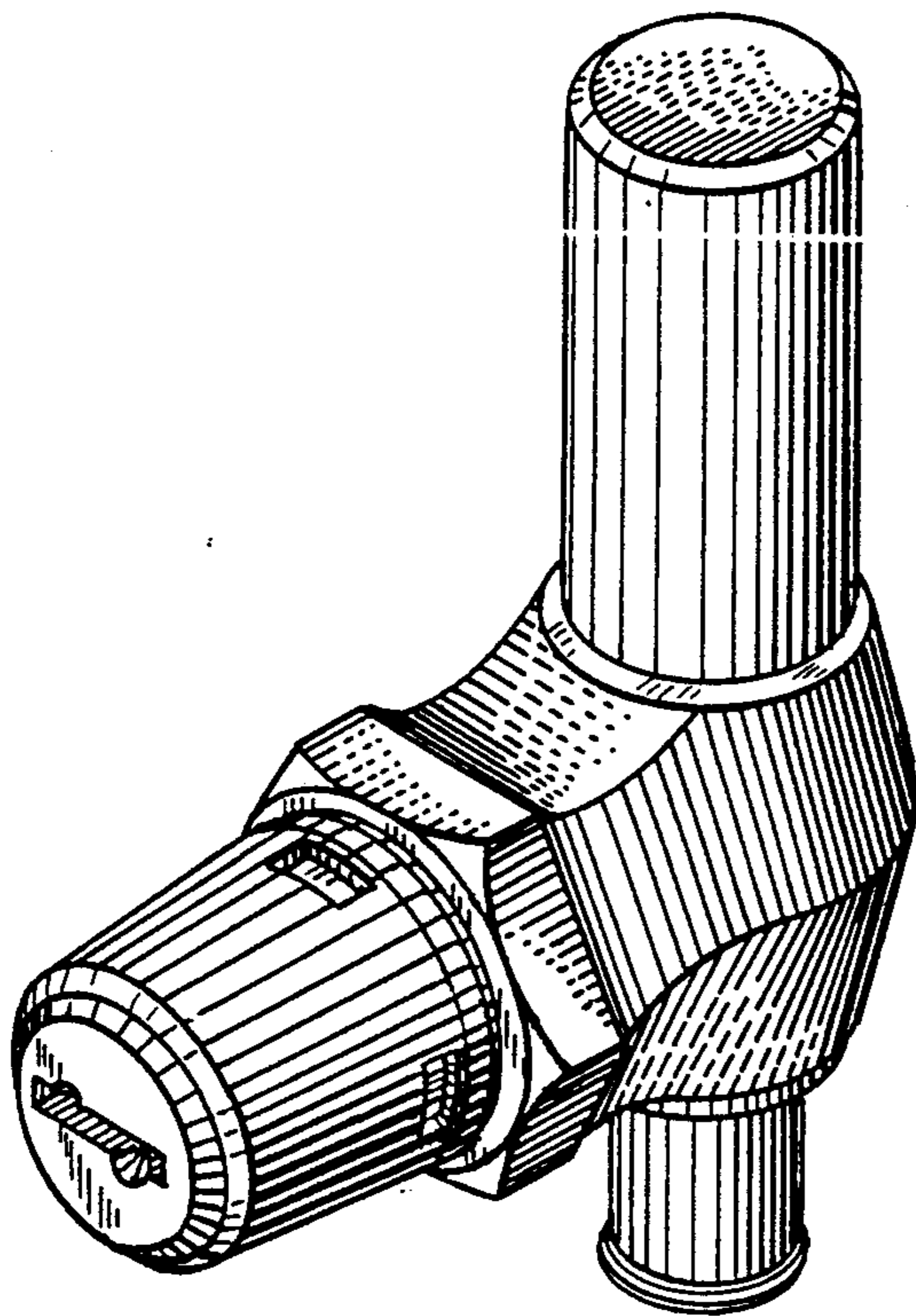

FIG. 1

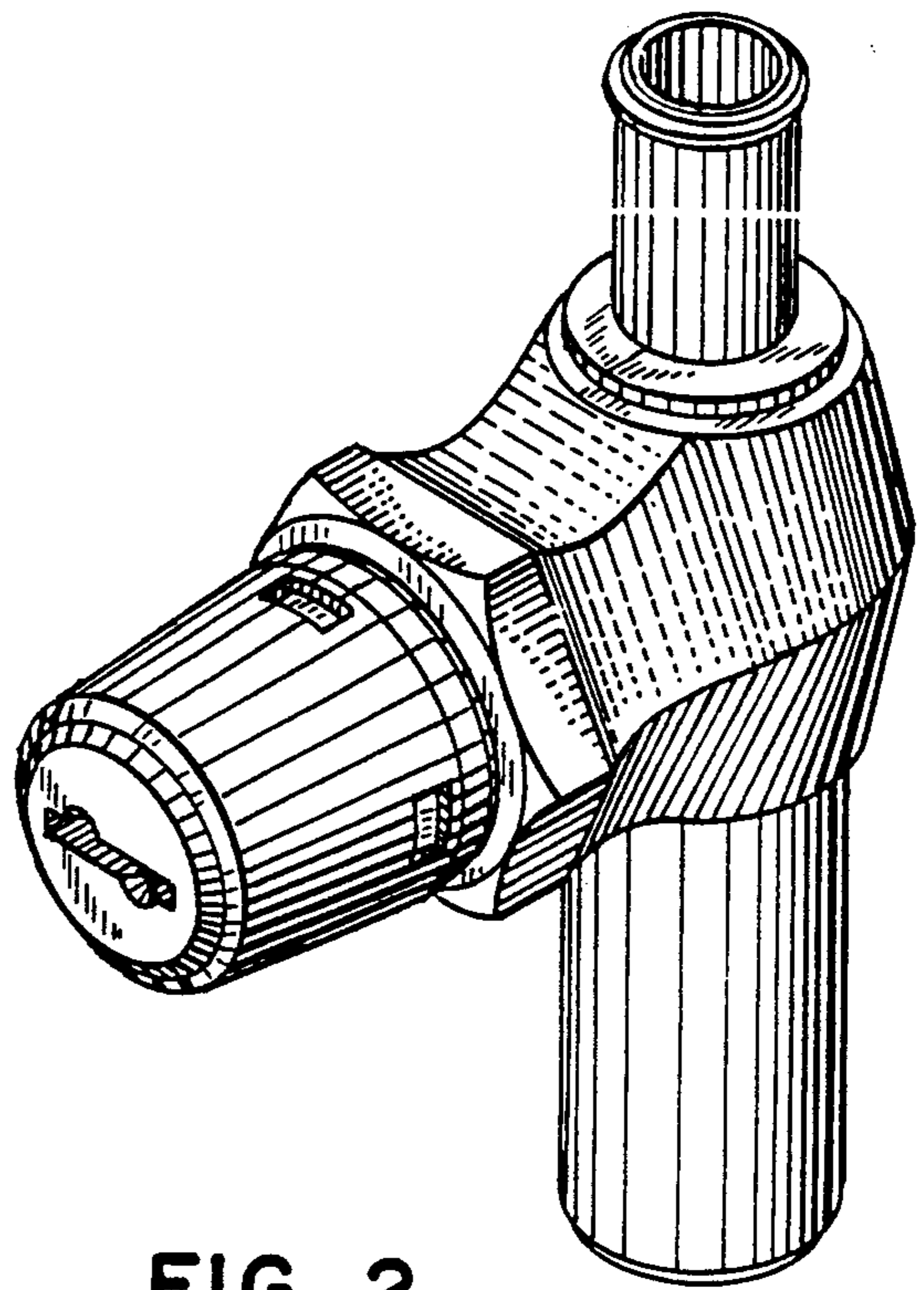

FIG. 2

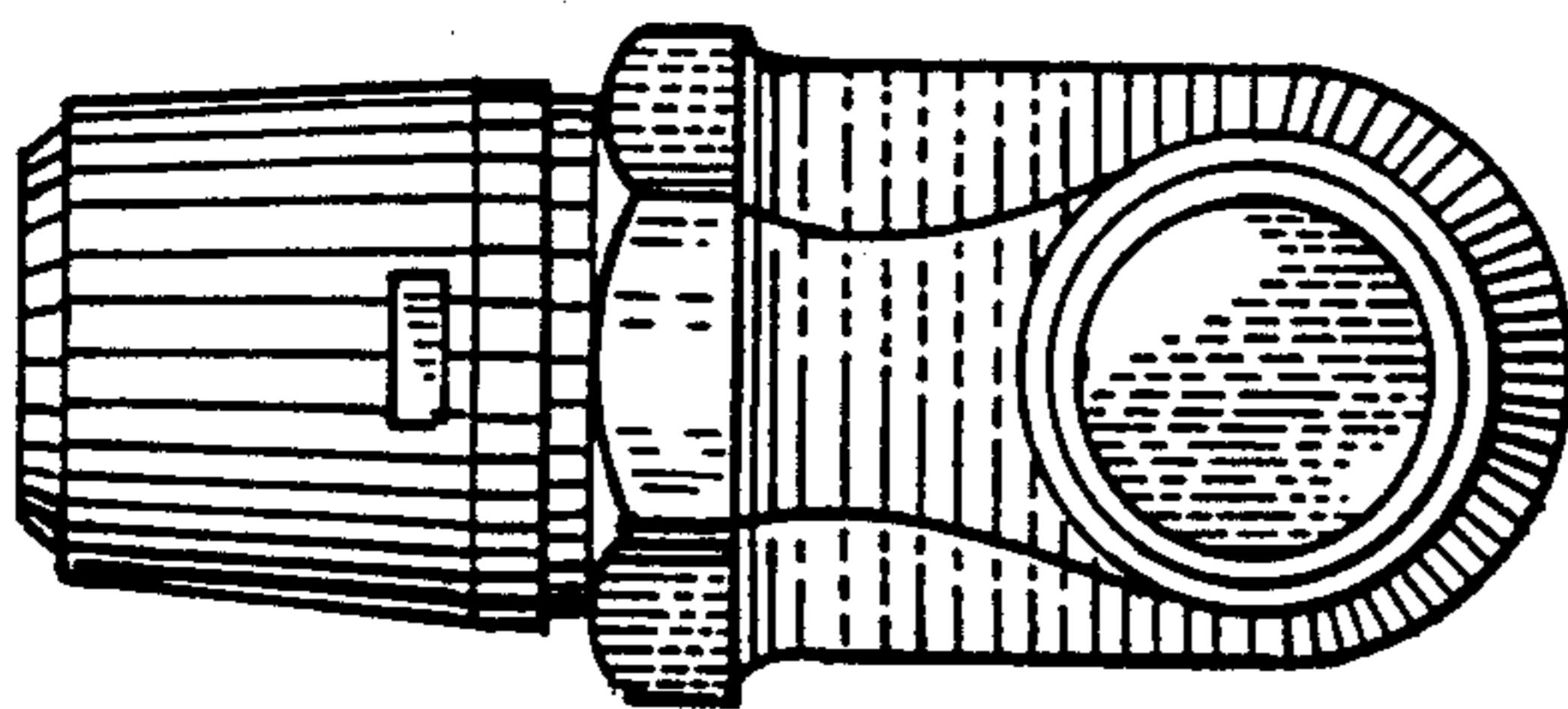

FIG. 3

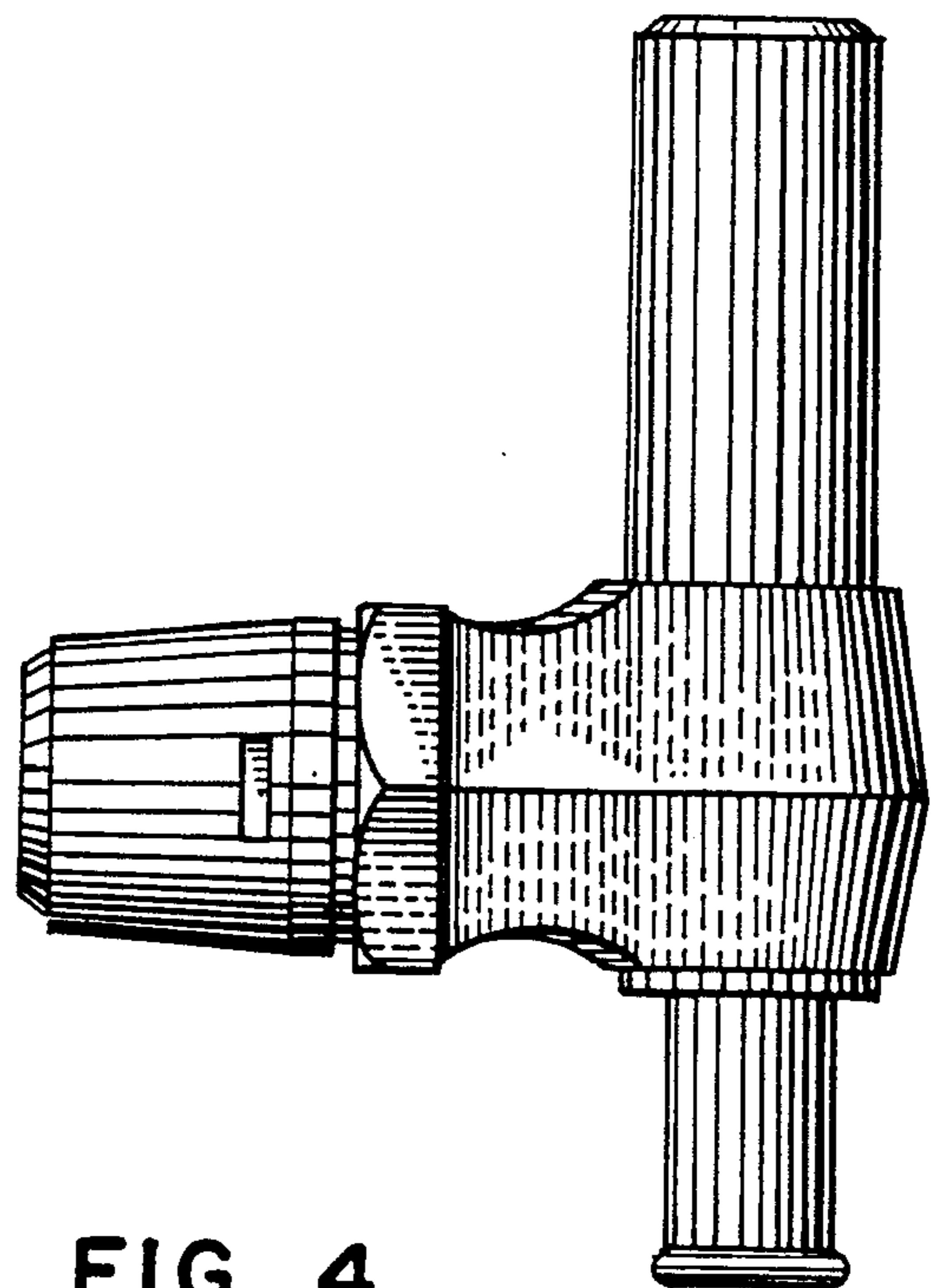

FIG. 4

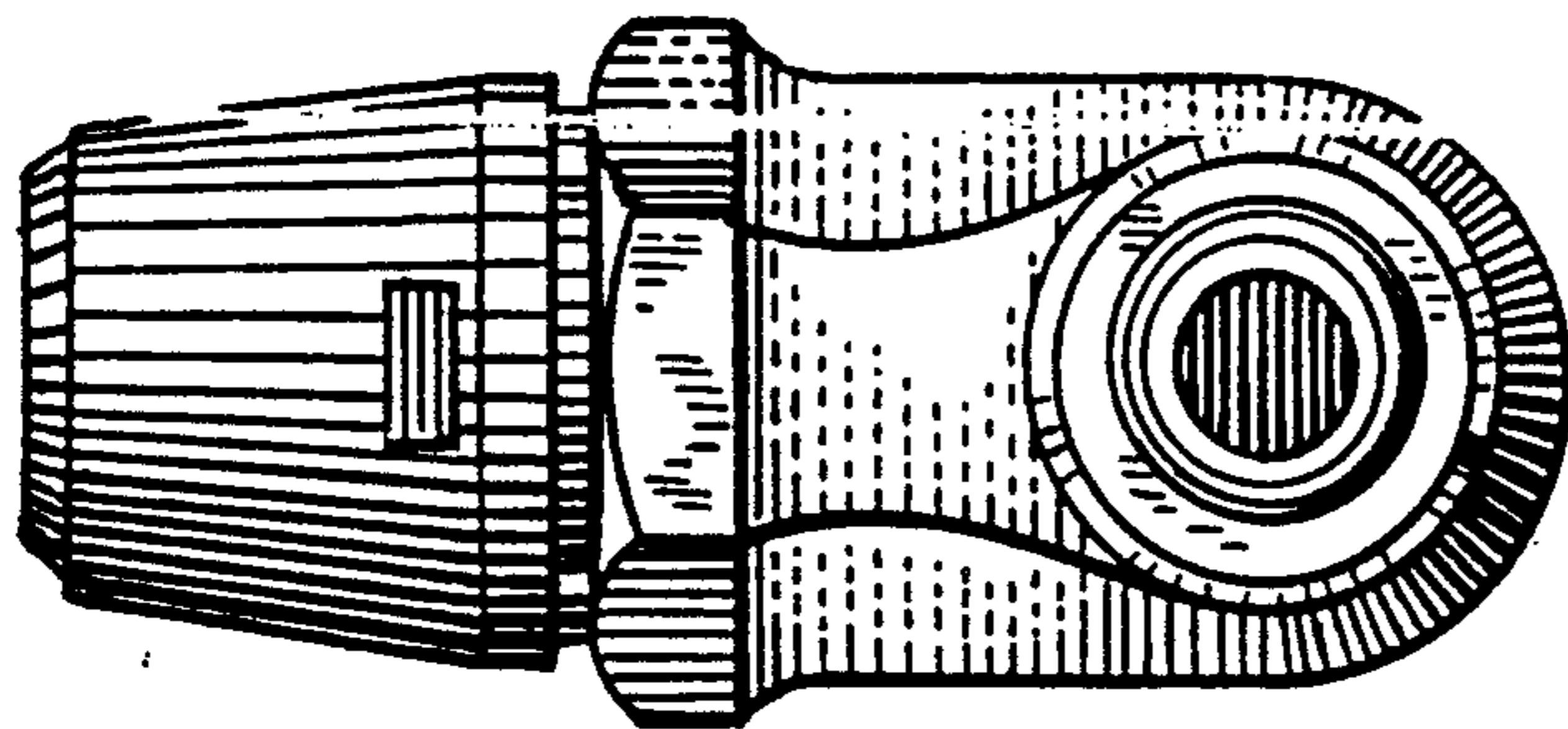

FIG. 6

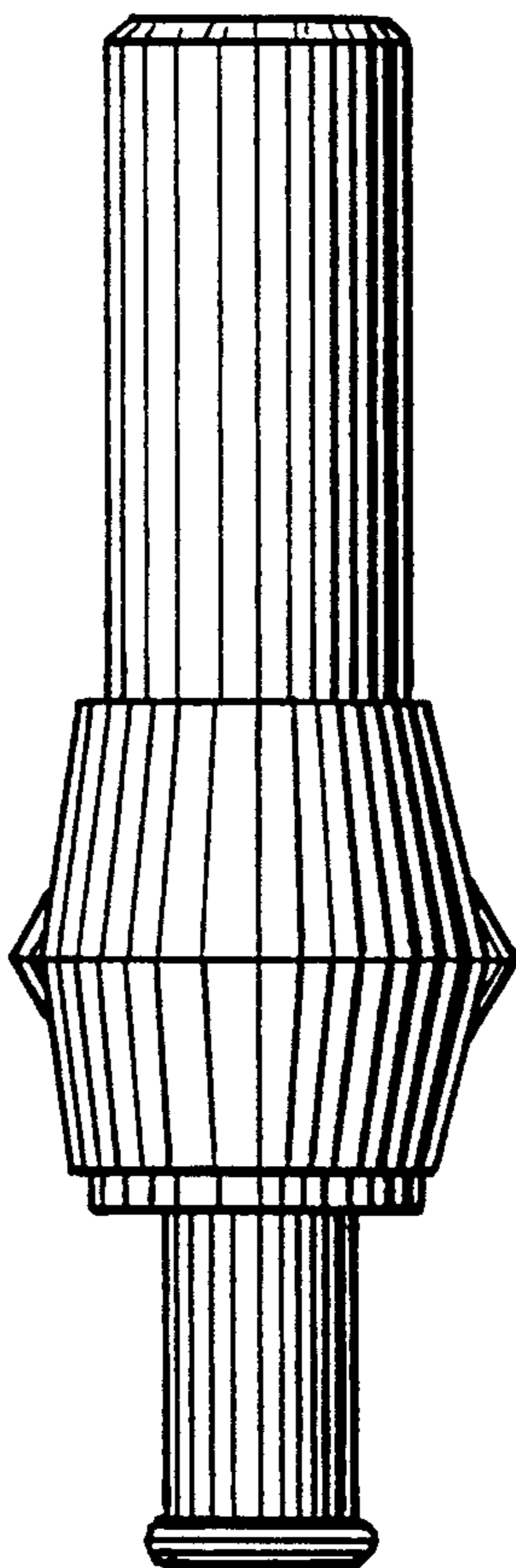

FIG. 7

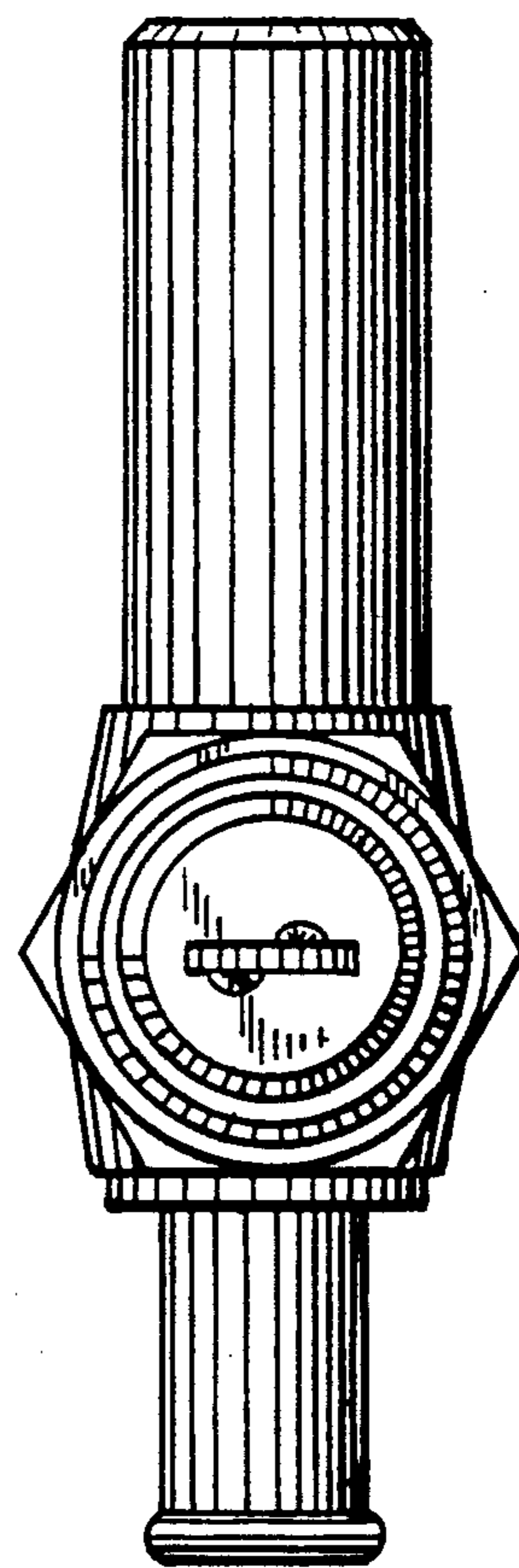

FIG. 5