

[54] **FRAME FOR A VEHICLE SEAT BACK**
[75] **Inventor: Edward A. Stulik, Roseville, Calif.**
[73] **Assignee: Sears Manufacturing Co., Davenport, Iowa**
[**] **Term: 14 Years**
[21] **Appl. No.: 180,858**
[22] **Filed: Apr. 12, 1988**
[52] **U.S. Cl. D6/500**
[58] **Field of Search D6/491, 495, 496, 498, D6/499-502, 486, 366, 393, 480, 482, 489, 363; 297/300, 292, 285, 457**

[56] **References Cited**
U.S. PATENT DOCUMENTS
D. 303,878 10/1989 Goldsmith D6/500 X
4,418,958 12/1983 Watken D6/366 X
4,711,497 12/1987 Kazaoka et al. 297/460 X

Primary Examiner—Bruce W. Dunkins
Assistant Examiner—Janice E. Seeger

Attorney, Agent, or Firm—Henderson & Sturm

[57] **CLAIM**
The ornamental design for a frame for a vehicle seat back, as shown and described.

DESCRIPTION
FIG. 1 is a side elevational view of a frame for a vehicle seat back showing my new design;
FIG. 2 is a rear elevational view thereof;
FIG. 3 is a rear perspective view thereof;
FIG. 4 is a front perspective view thereof;
FIG. 5 is a cross sectional view taken along line 5—5 in FIG. 2;
FIG. 6 is a cross sectional view thereof taken along line 6—6 in FIG. 2;
FIG. 7 is a cross sectional view taken along line 7—7 of FIG. 2;
FIG. 8 is a cross sectional view taken along line 8—8 of FIG. 2; and
FIG. 9 is a cross sectional view taken along line 9—9 of FIG. 2.
The broken lines in FIGS. 1 and 2 are for illustrative purposes only.

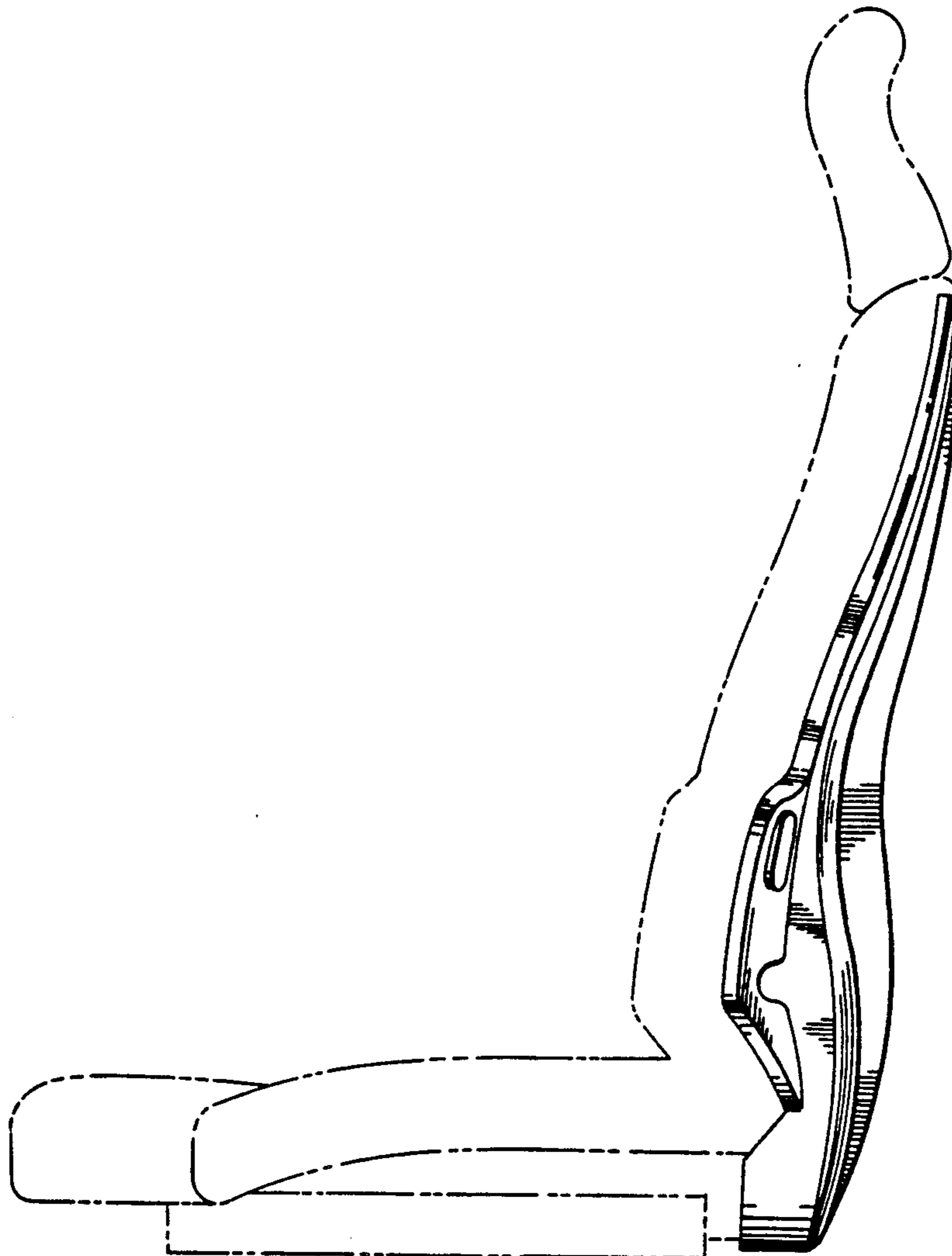
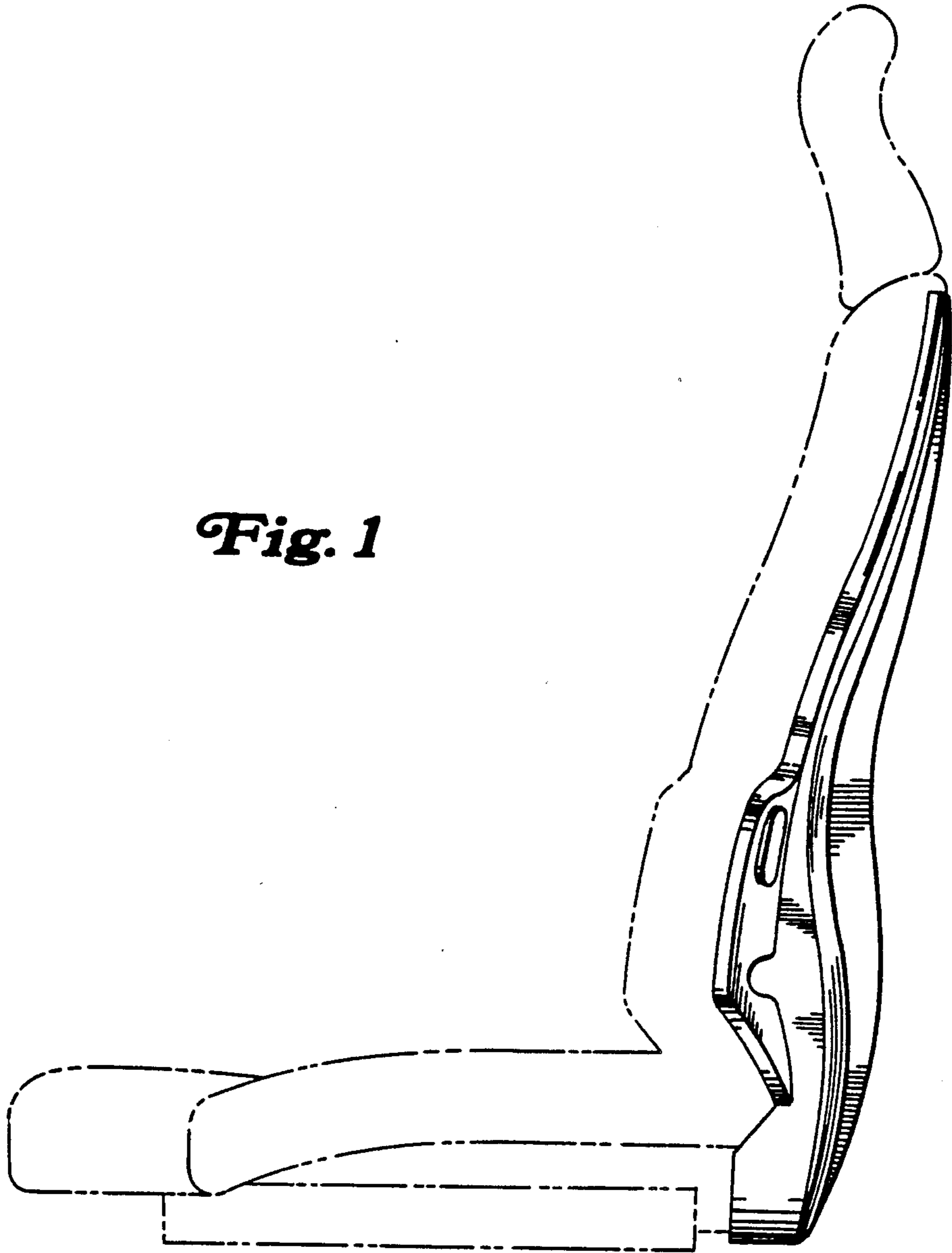

Fig. 1



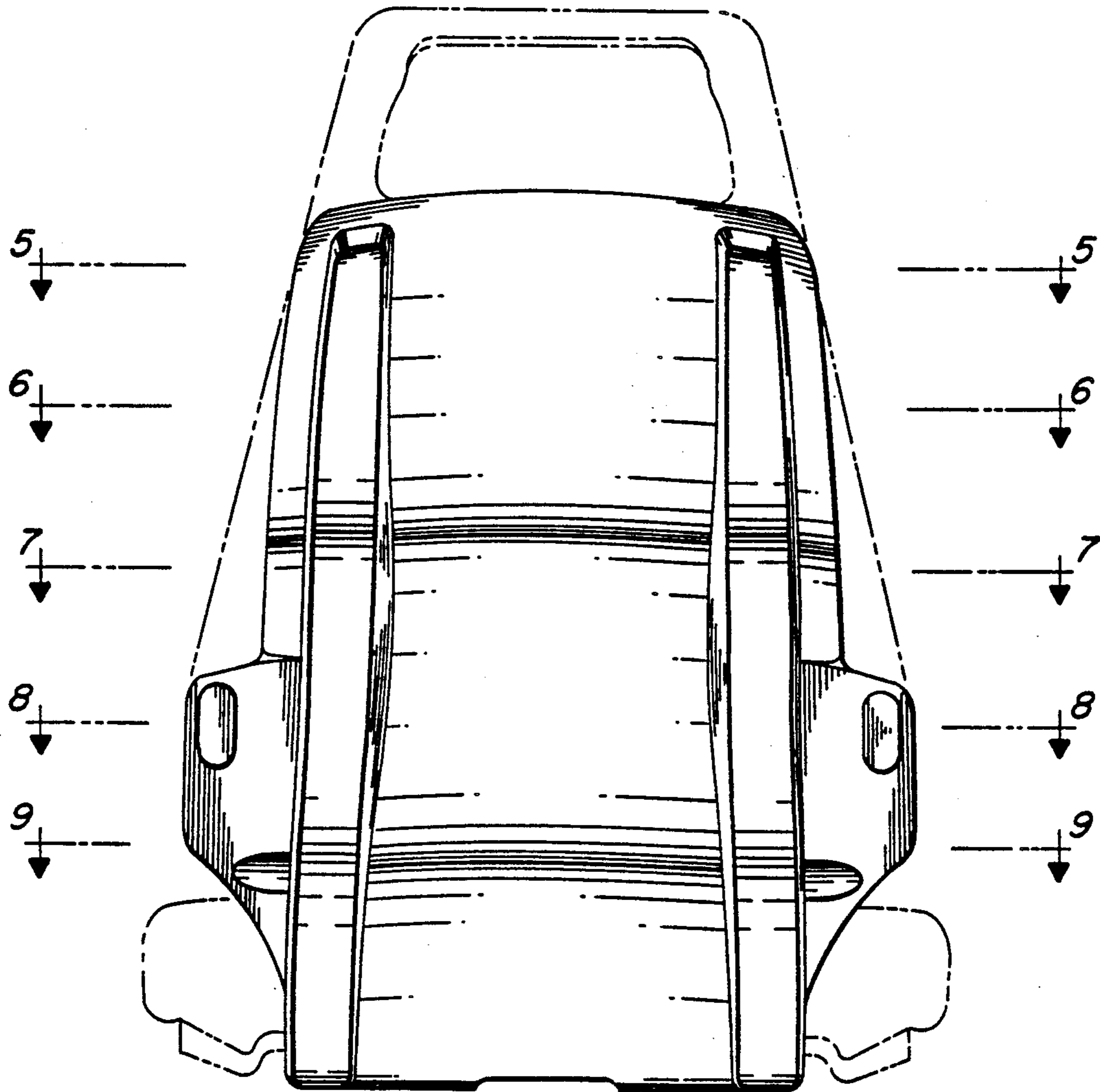

Fig. 2

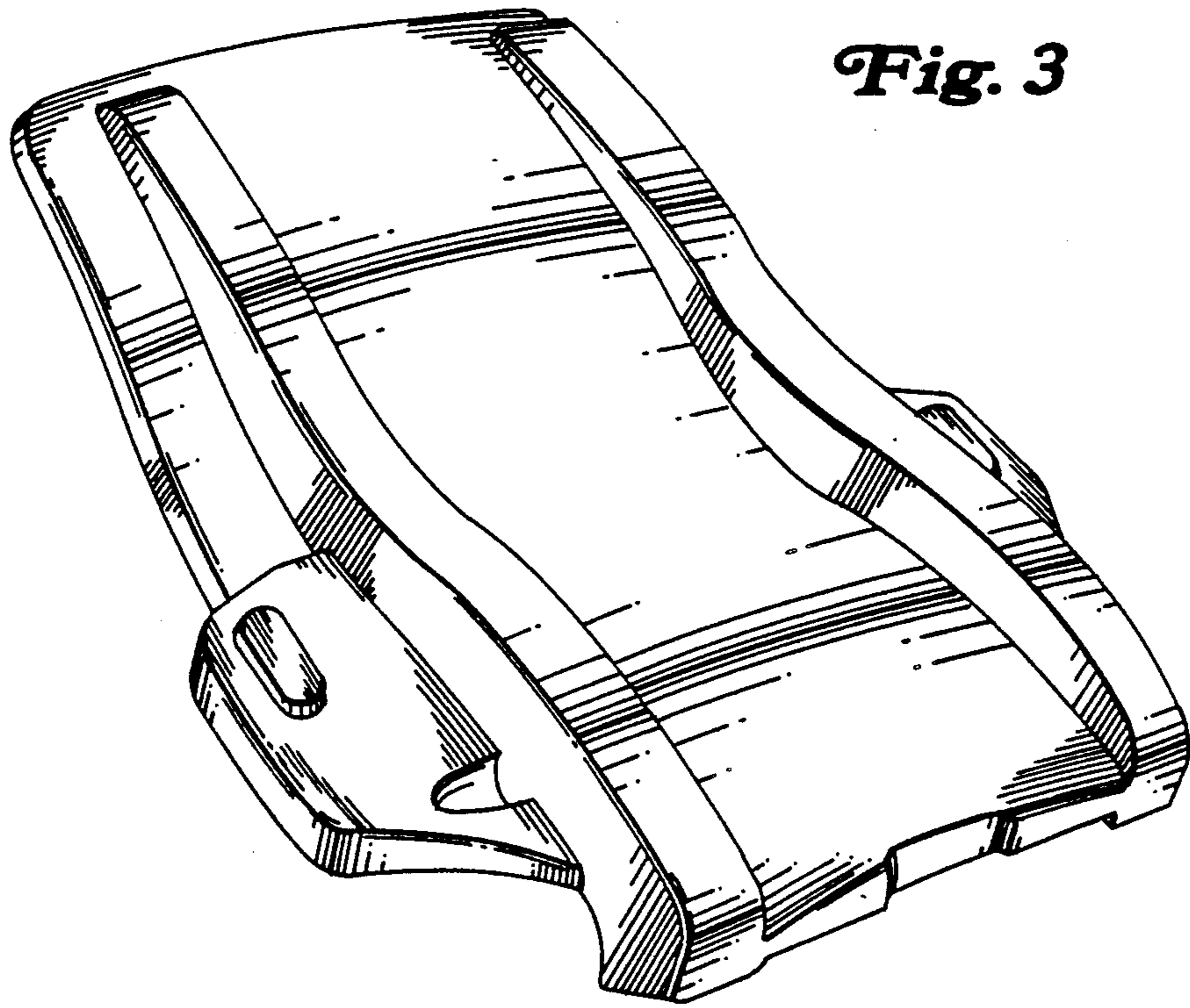

Fig. 3

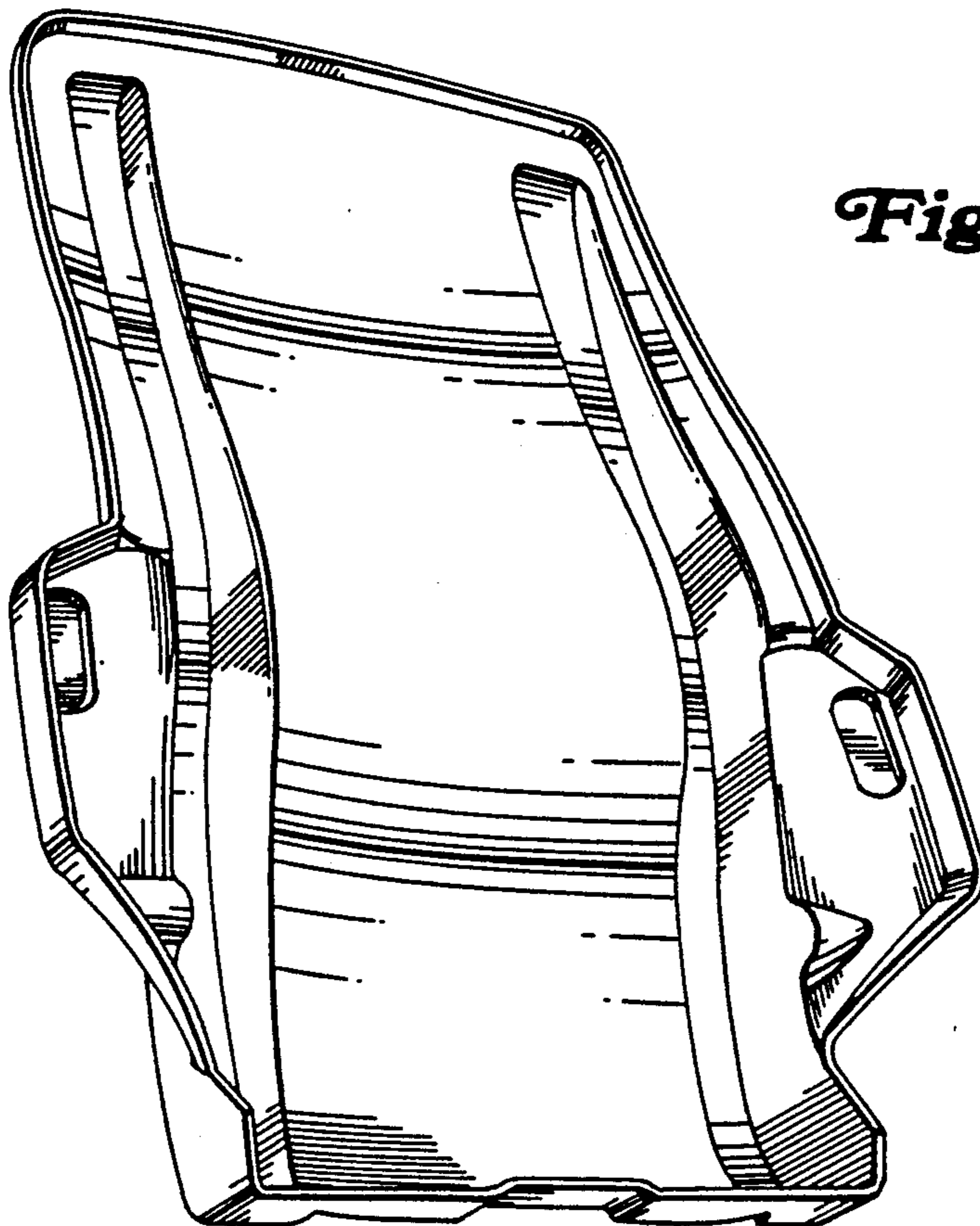

Fig. 4

Fig. 5



Fig. 6



Fig. 7

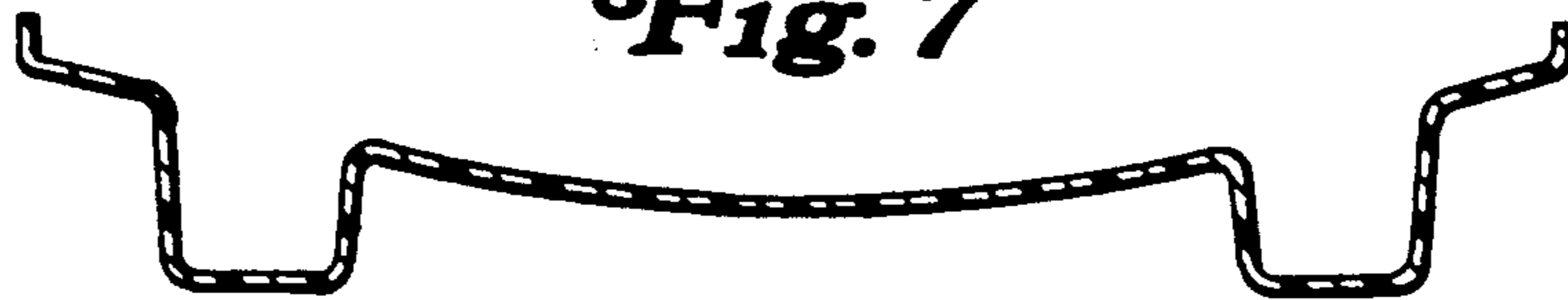

Fig. 8

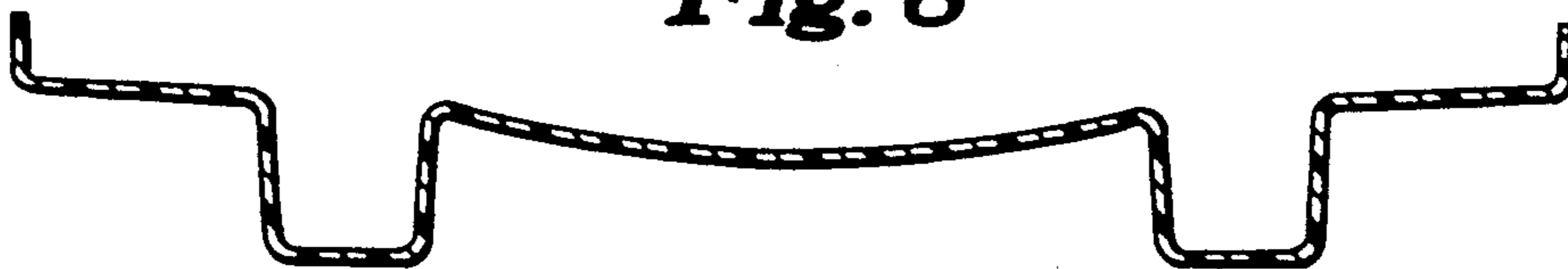

Fig. 9

