

United States Patent [19]

van der Merwe et al.

[11] Patent Number: Des. 313,955

[45] Date of Patent: ** Jan. 22, 1991

[54] TRAILER

4,372,568 2/1983 Campbell 280/63
4,502,725 2/1985 Wiant 296/156

[76] Inventors: **Jacobus C. van der Merwe**, 801 Beechwood Dr., Kingsport, Tenn. 37663; **Lucas C. van der Merwe**, 205 Pendleton Rd. Blountville, Tenn. 37617

[**] Term: **14 Years**

[21] Appl. No.: **221,238**

[22] Filed: **Jul. 19, 1988**

[52] U.S. Cl. **D12/102**

[58] Field of Search **D12/102; 280/418.1, 280/491.1; 296/181, 24.1, 156**

[56] **References Cited**

U.S. PATENT DOCUMENTS

D. 240,213	6/1976	Beckwith	D12/102
D. 248,291	6/1978	Boldt	D12/102
D. 256,114	7/1980	Bell, Jr.	D12/102
D. 268,178	3/1983	Reid	D12/102
D. 272,525	2/1984	Paulina	D12/102
3,434,735	3/1969	Bernard	280/406

OTHER PUBLICATIONS

Popular Science Magazine, Sep. 1976, p. 86, Cycle Trailer.

Primary Examiner—James M. Gandy
Assistant Examiner—Melody Brown
Attorney, Agent, or Firm—Fleit, Jacobson, Cohn, Price, Holman & Stern

[57] CLAIM

The ornamental design for a trailer, as shown.

DESCRIPTION

FIG. 1 is a front perspective view of a trailer showing our new design;
FIG. 2 is a top plan view thereof;
FIG. 3 is a front elevation view thereof;
FIG. 4 is a rear perspective view thereof;
FIG. 5 is a side elevation view thereof; and
FIG. 6 is a bottom plan view thereof.

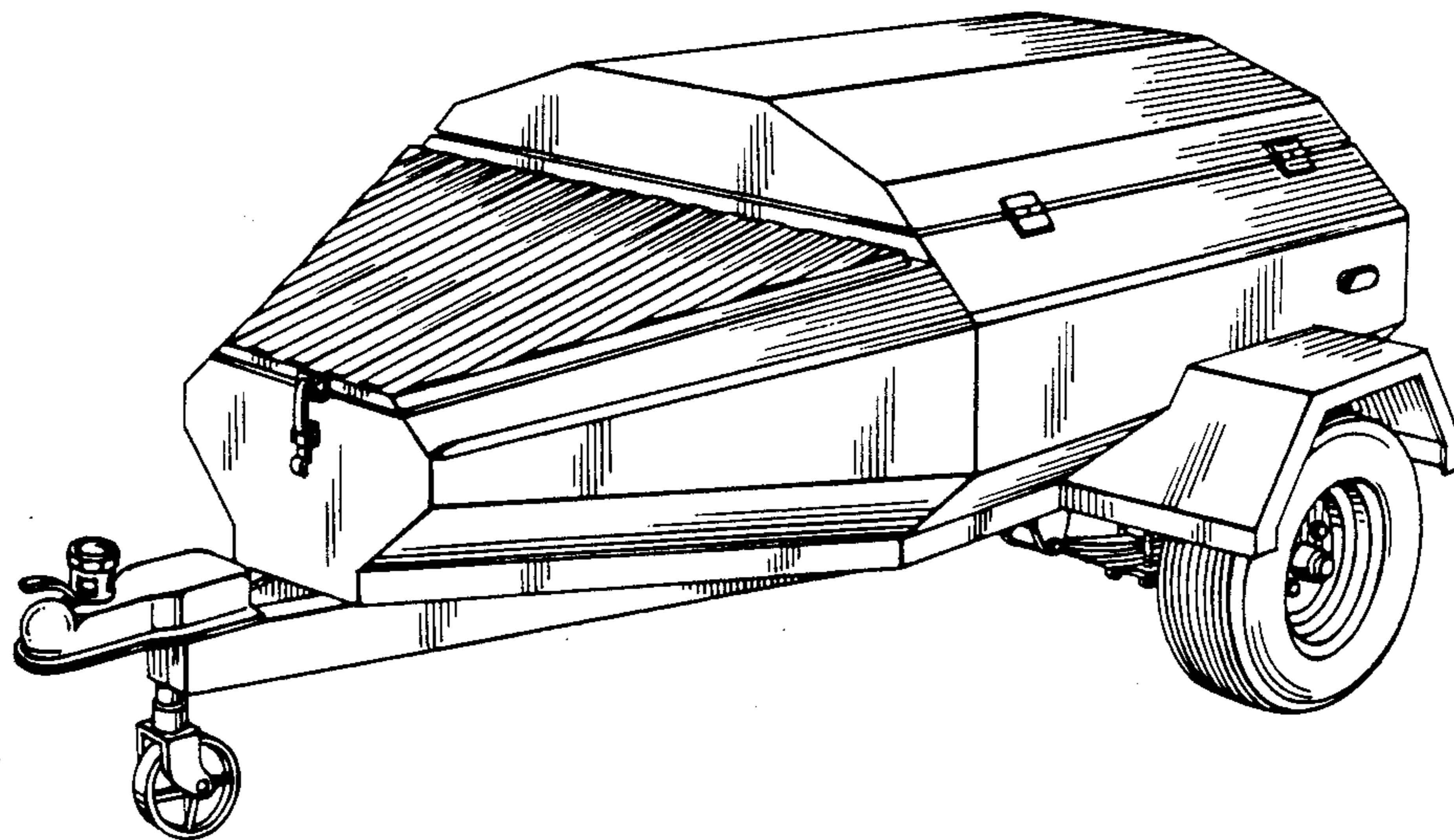

FIG. 1

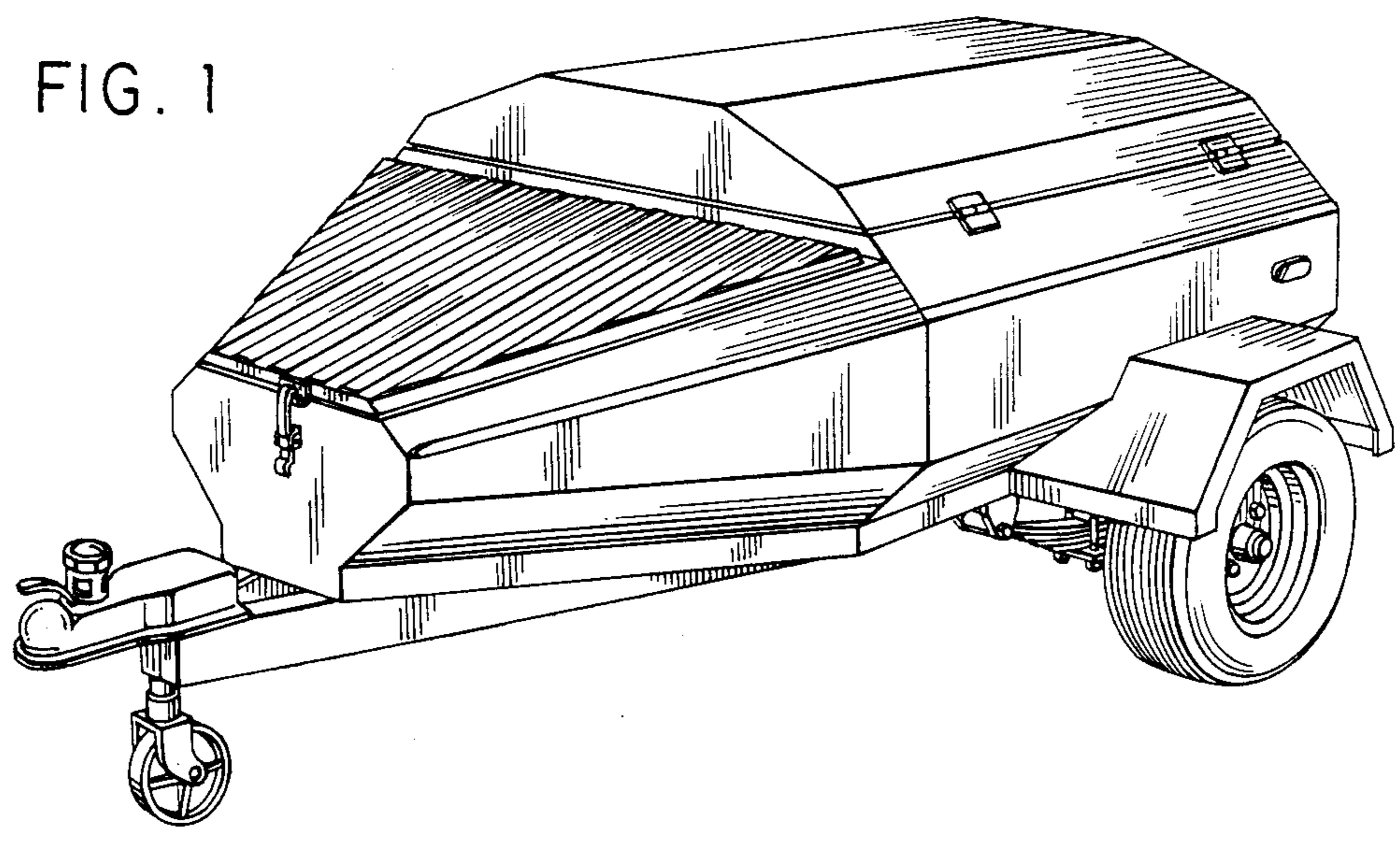

FIG. 2

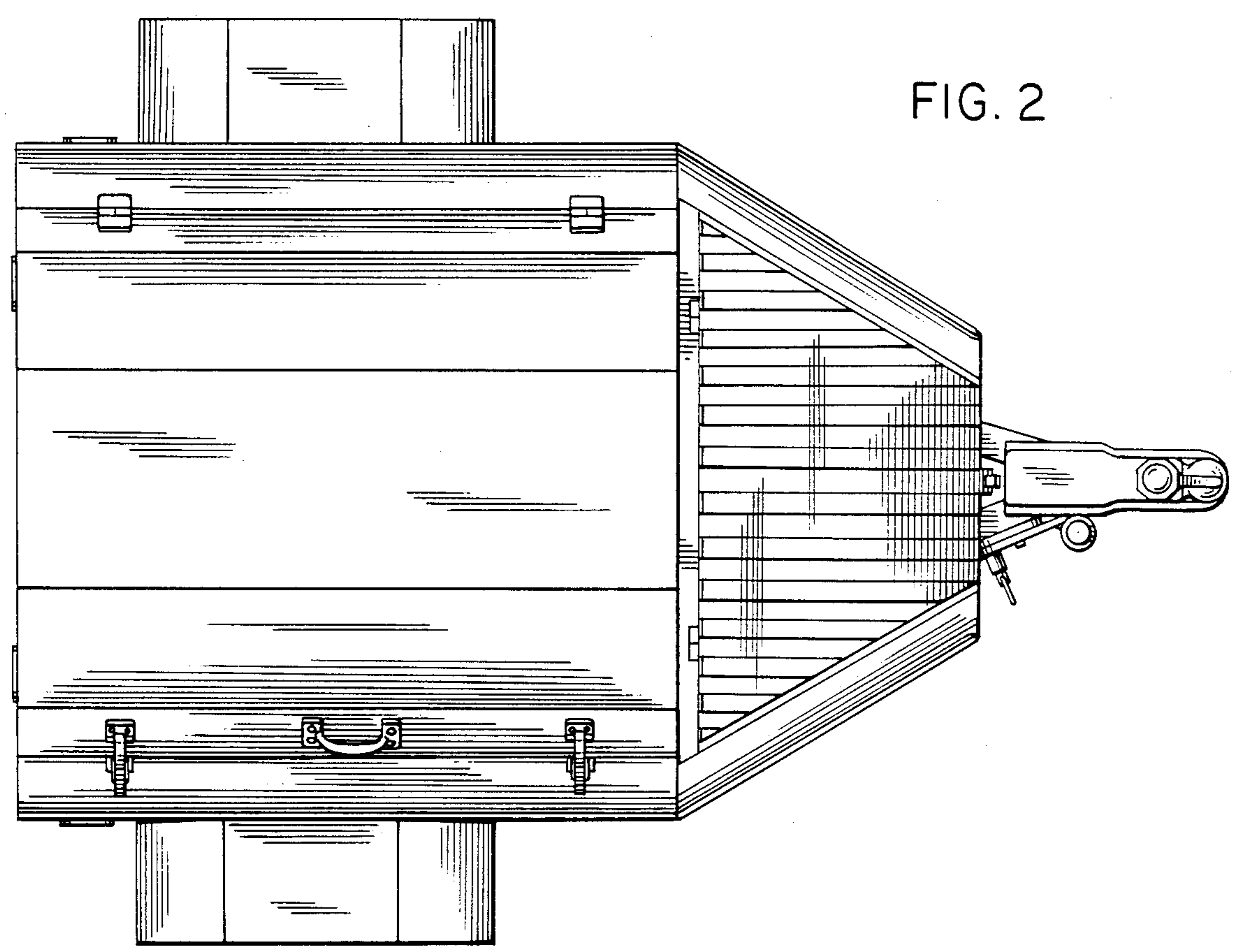

FIG. 3

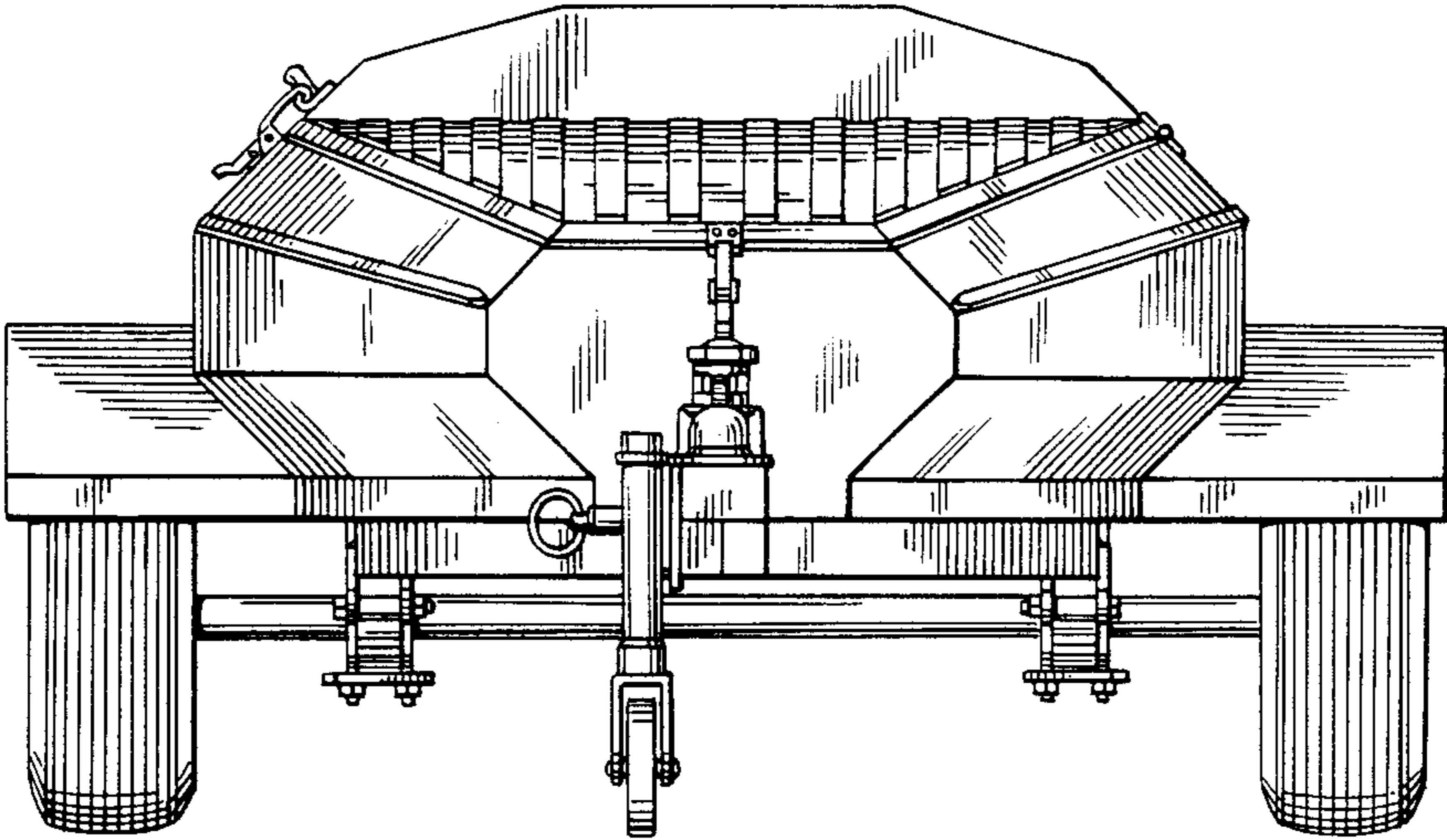

FIG. 4

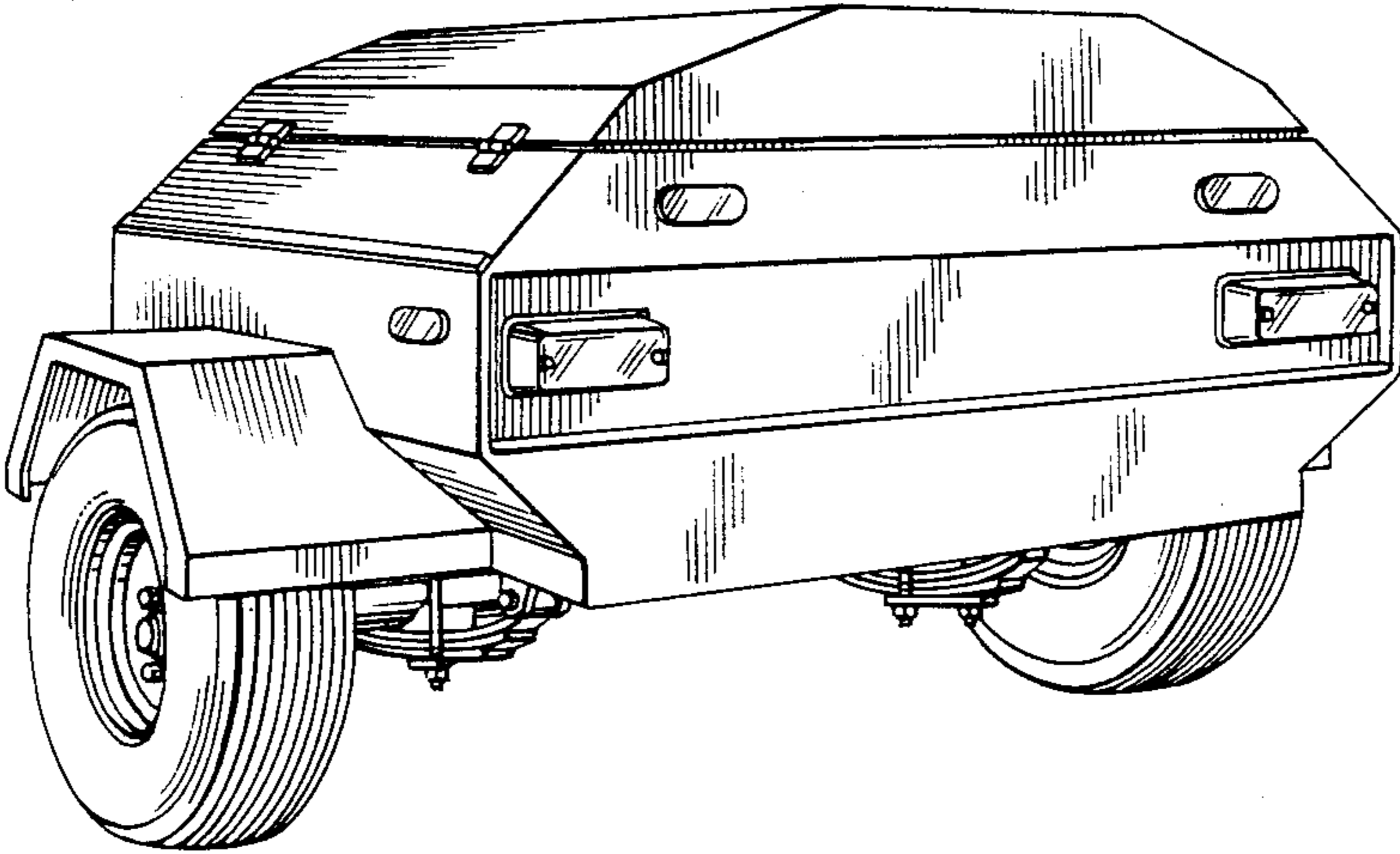

FIG. 5

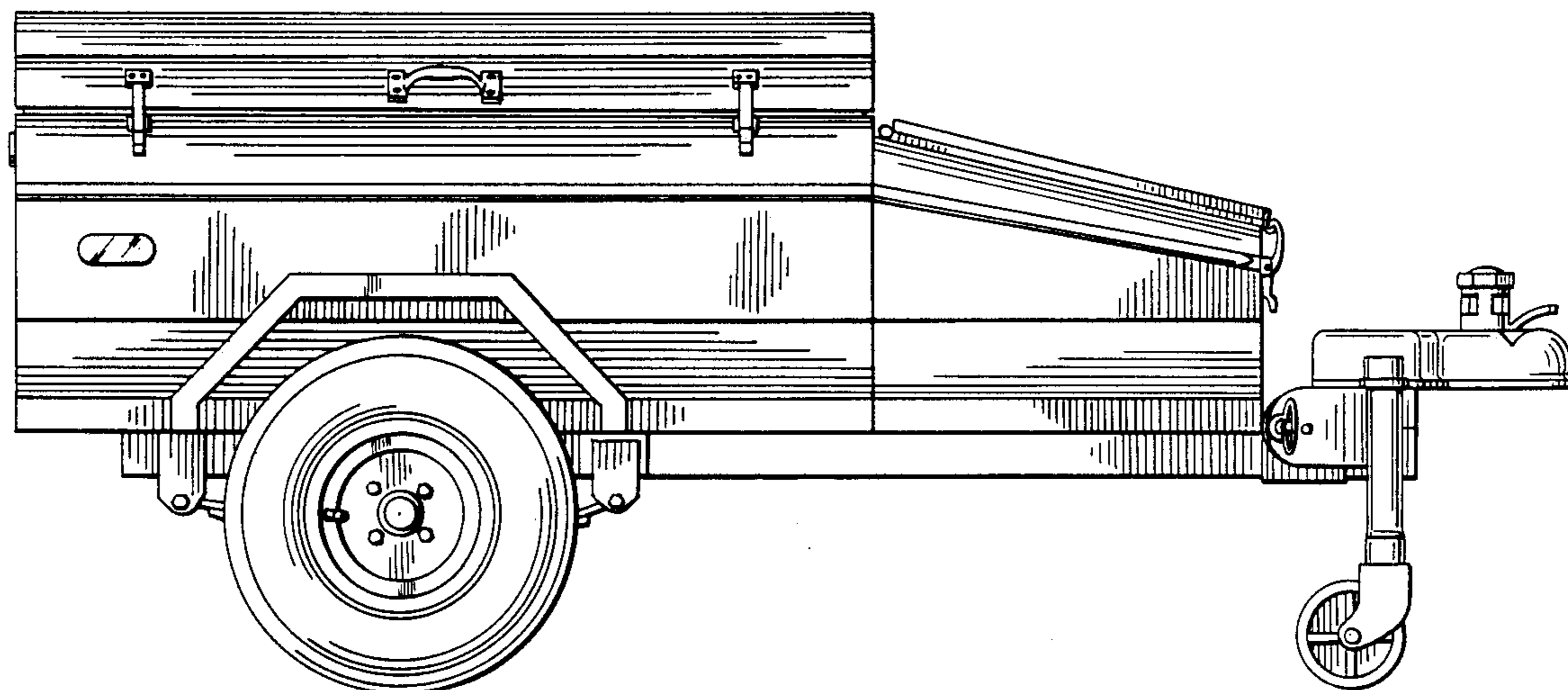

FIG. 6

