

[54] SINGLE WHEEL CASTOR WITH STABILIZER AND VIBRATION DAMPER FOR TRANSPORT OF HEAVY MACHINES

4,077,086 3/1978 Butke 16/33
4,385,415 5/1983 Volz 16/29
4,759,098 7/1988 Ko 16/29

[75] Inventor: Masaru Orii, Tokyo, Japan

FOREIGN PATENT DOCUMENTS

[73] Assignee: Kabushikigaisha Orii, Kanagawa, Japan

198662 9/1938 Switzerland 16/33

[**] Term: 14 Years

OTHER PUBLICATIONS

[21] Appl. No.: 184,623

Colson, Twin-Tech Plunger-Lock Castor: 1 page flyer.

[22] Filed: Apr. 22, 1988

Primary Examiner—Horace B. Fay, Jr.
Attorney, Agent, or Firm—Collard, Roe & Galgano

[30] Foreign Application Priority Data

Oct. 27, 1987 [JP] Japan 62-43848

[52] U.S. Cl. D8/375

[58] Field of Search D8/375, 374; 16/33, 16/44, 29, 26, 32, 29, 47, 24, 48, 35; 248/24

[57] CLAIM

The ornamental design for a single wheel castor with stabilizer and vibration damper for transport of heavy machines, as shown and described.

DESCRIPTION

[56] References Cited

U.S. PATENT DOCUMENTS

- D. 205,847 9/1966 Good D8/375
- D. 221,616 8/1971 Hollander D8/374 X
- D. 306,397 3/1990 Kweon D8/375
- 1,532,064 3/1925 Neiswender 16/29 X
- 1,604,723 10/1926 Rutherford 16/29 X
- 1,895,882 1/1933 Herold 16/29 X
- 3,455,526 7/1969 Orii 248/24
- 3,602,464 8/1971 Orii 248/24
- 3,789,796 4/1975 Whyte 16/33 X

FIG. 1 is a left side, top and front perspective view of a single wheel castor with stabilizer and vibration damper for transport of heavy machines showing my new design;

FIG. 2 is a left side elevational view thereof;

FIGS. 3 and 4 are respectively rear and front elevational views thereof;

FIG. 5 is a right side elevational view thereof;

FIGS. 6 and 7 are respectively top and bottom plan views thereof; and

FIG. 8 is a left side elevational view thereof with the vibration damper in lowered position.

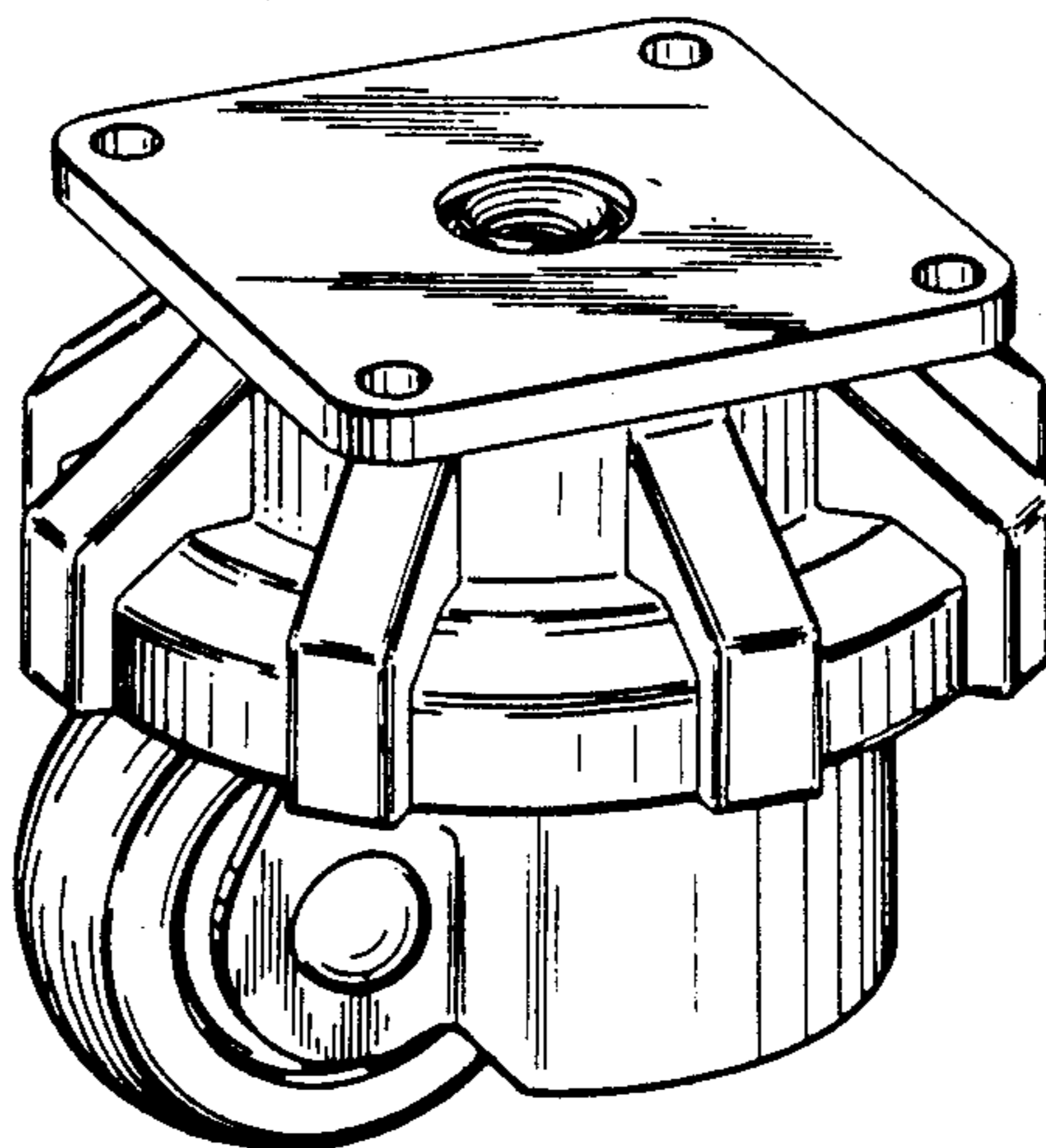

FIG. 1

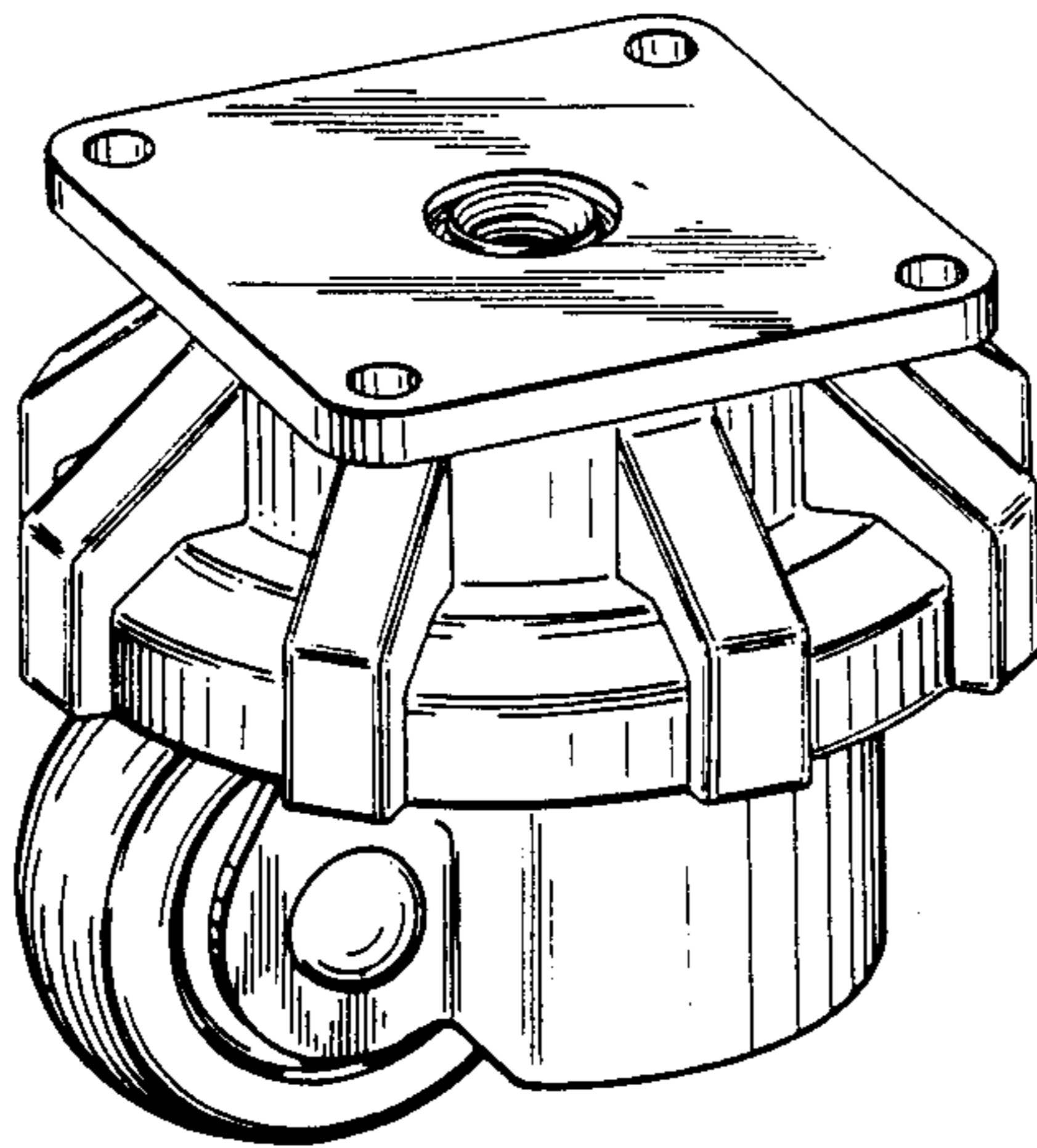

FIG. 2

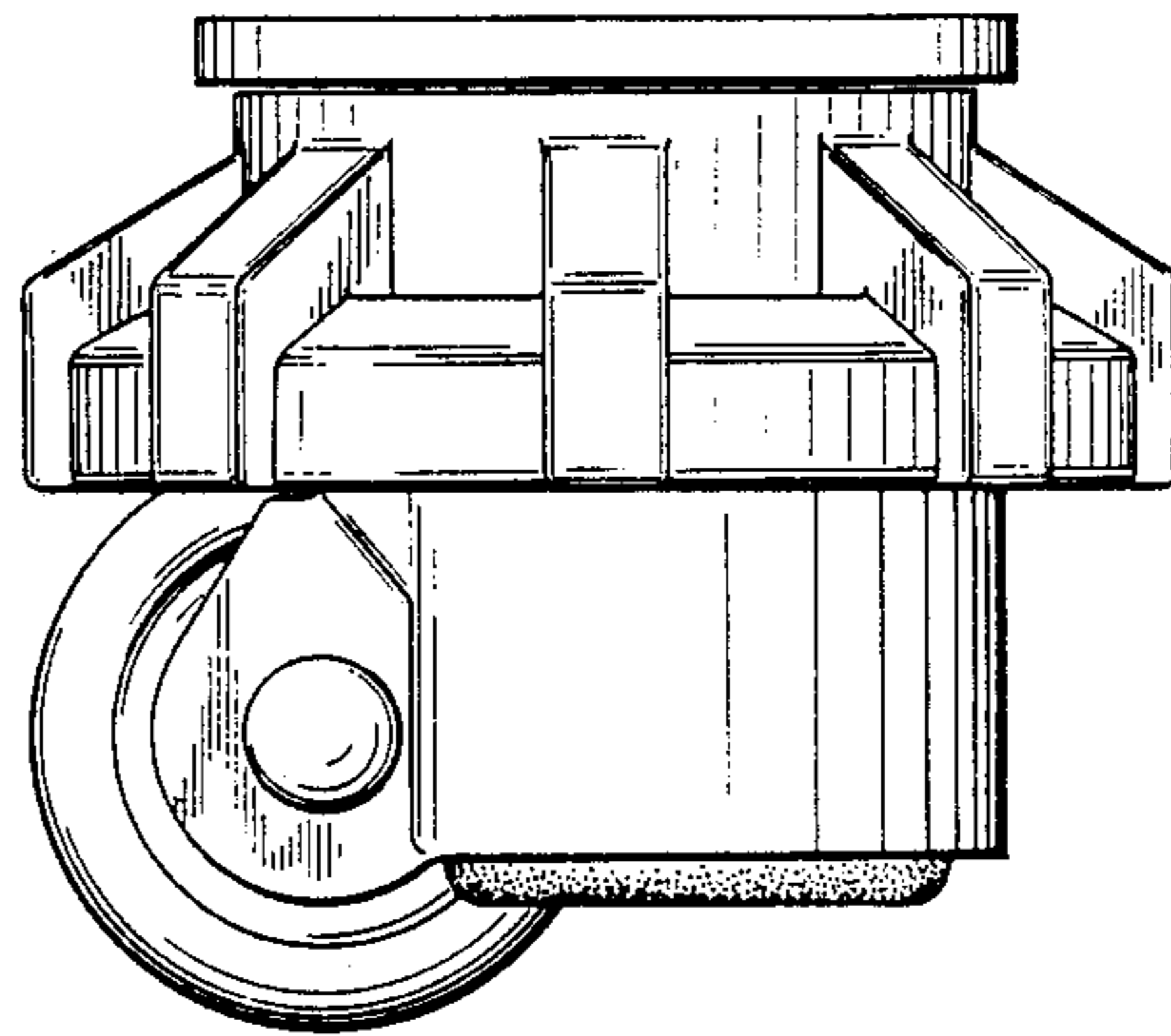

FIG. 3

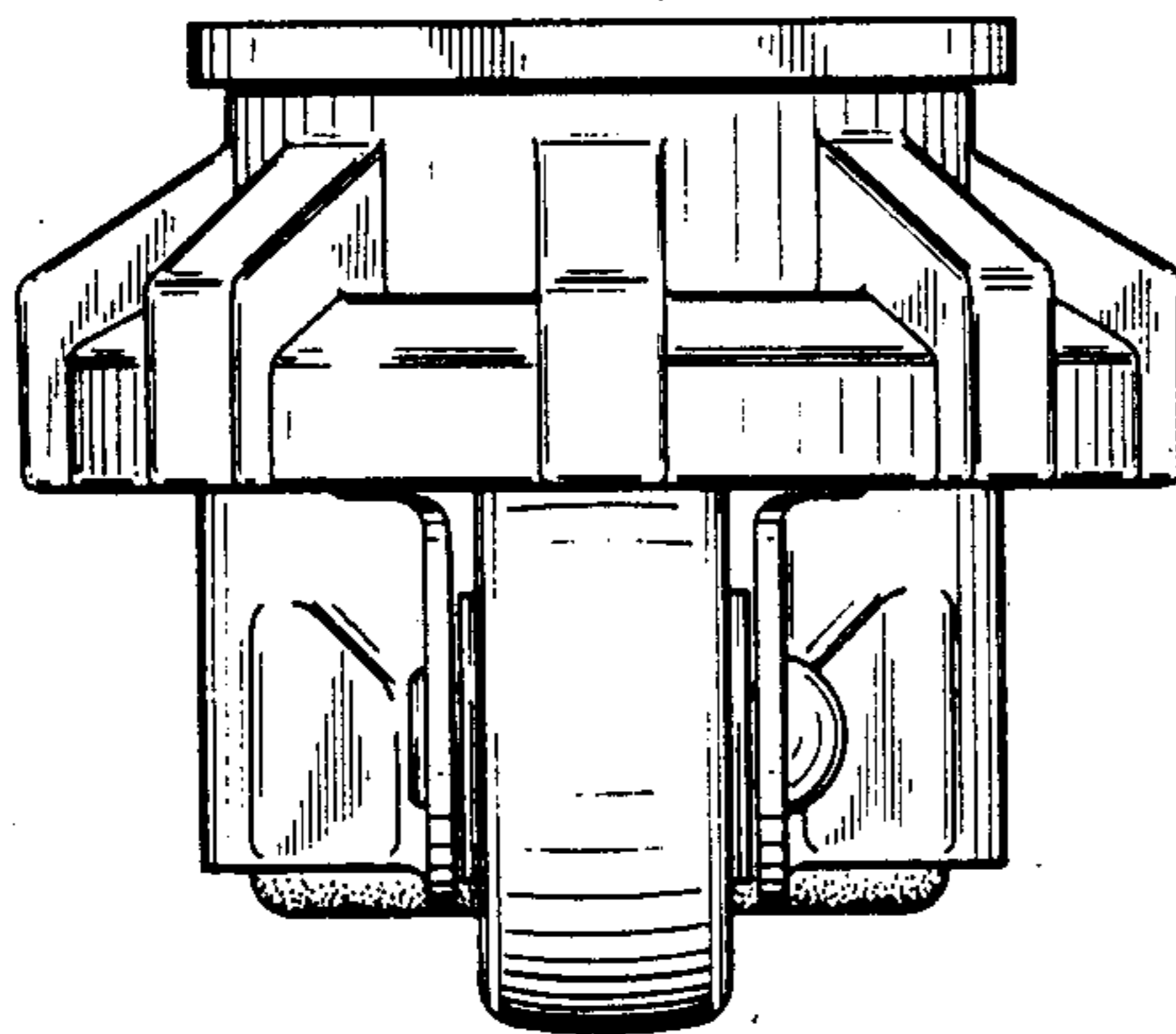

FIG. 4

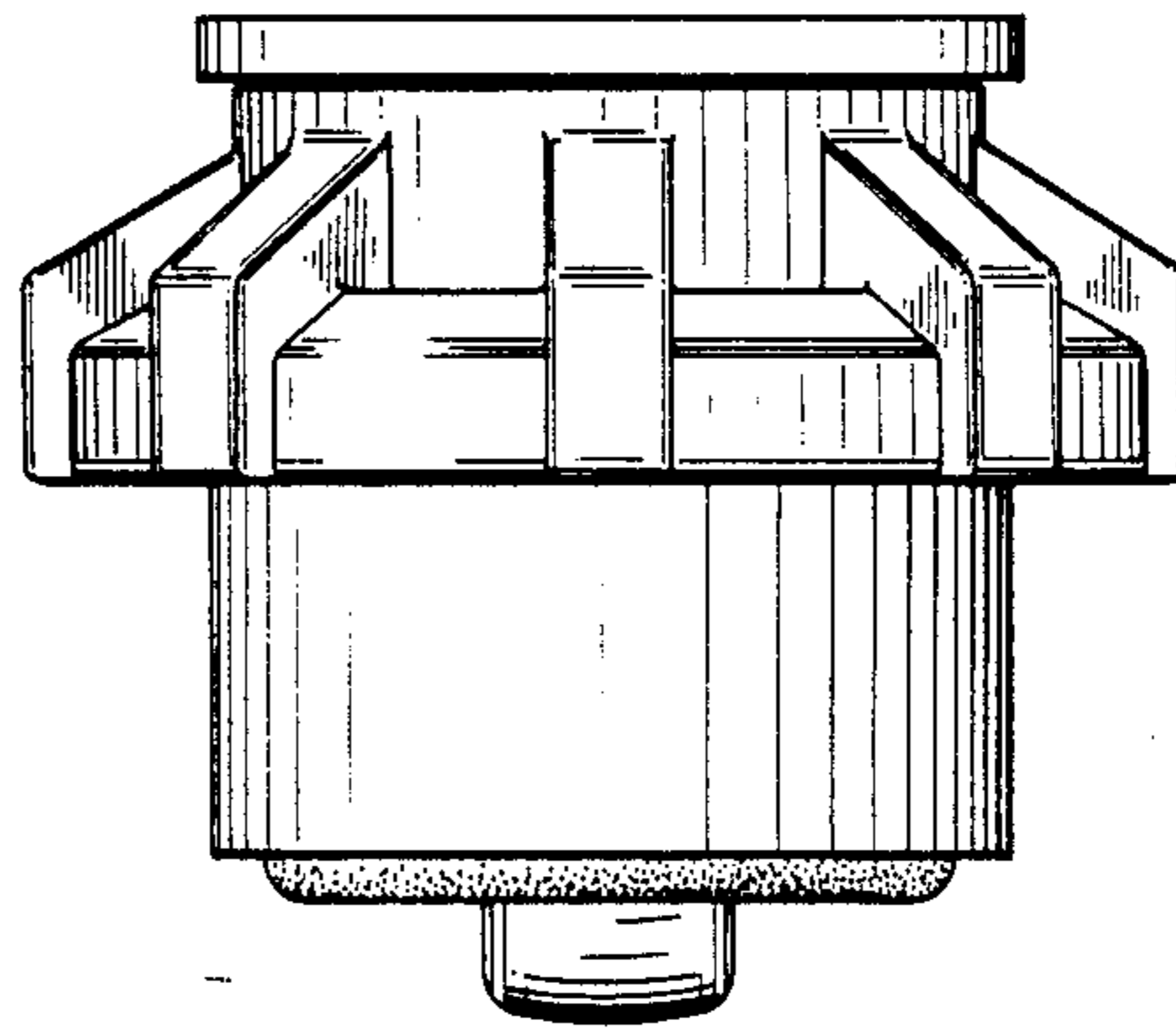

FIG. 5

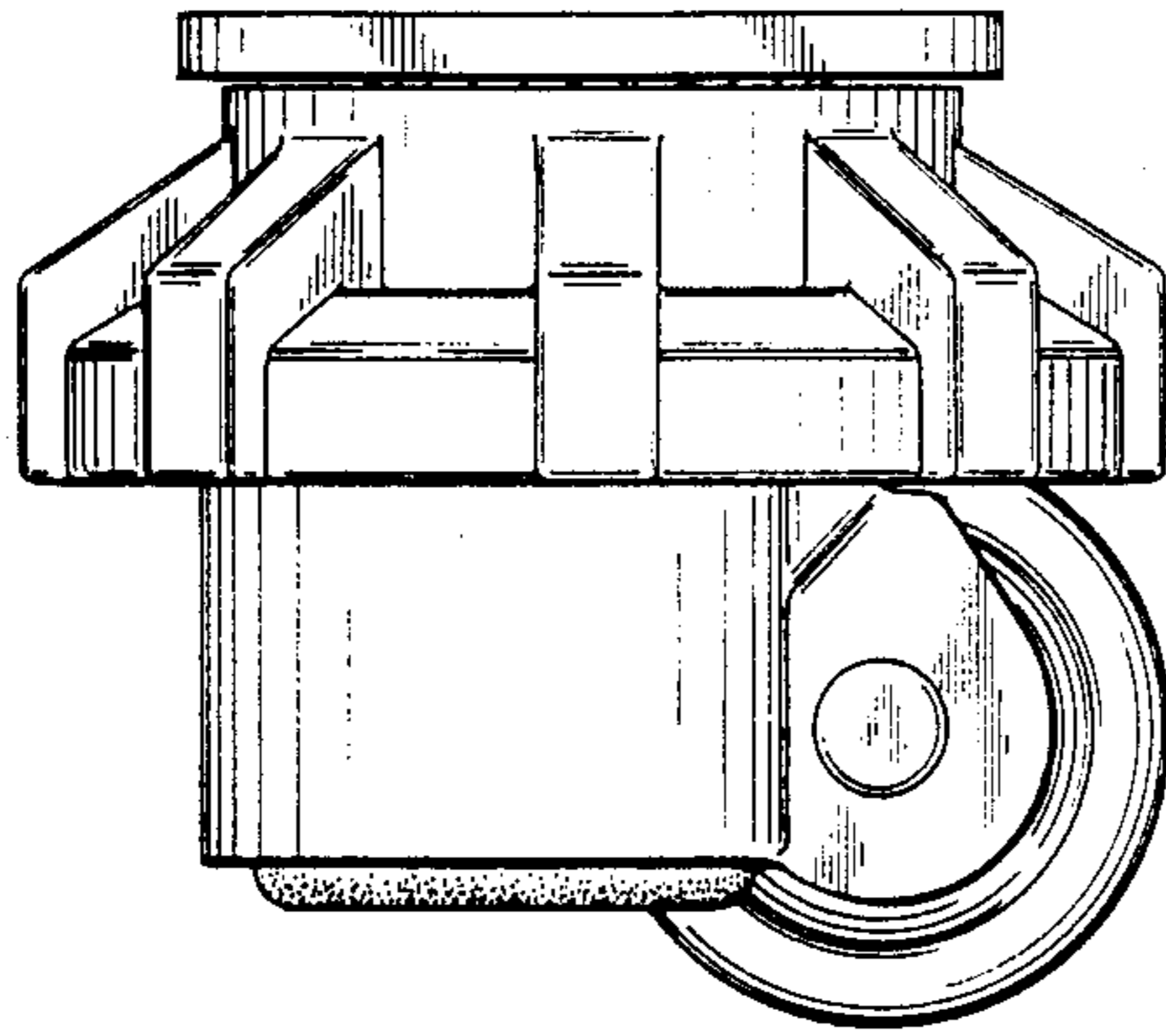

FIG. 6

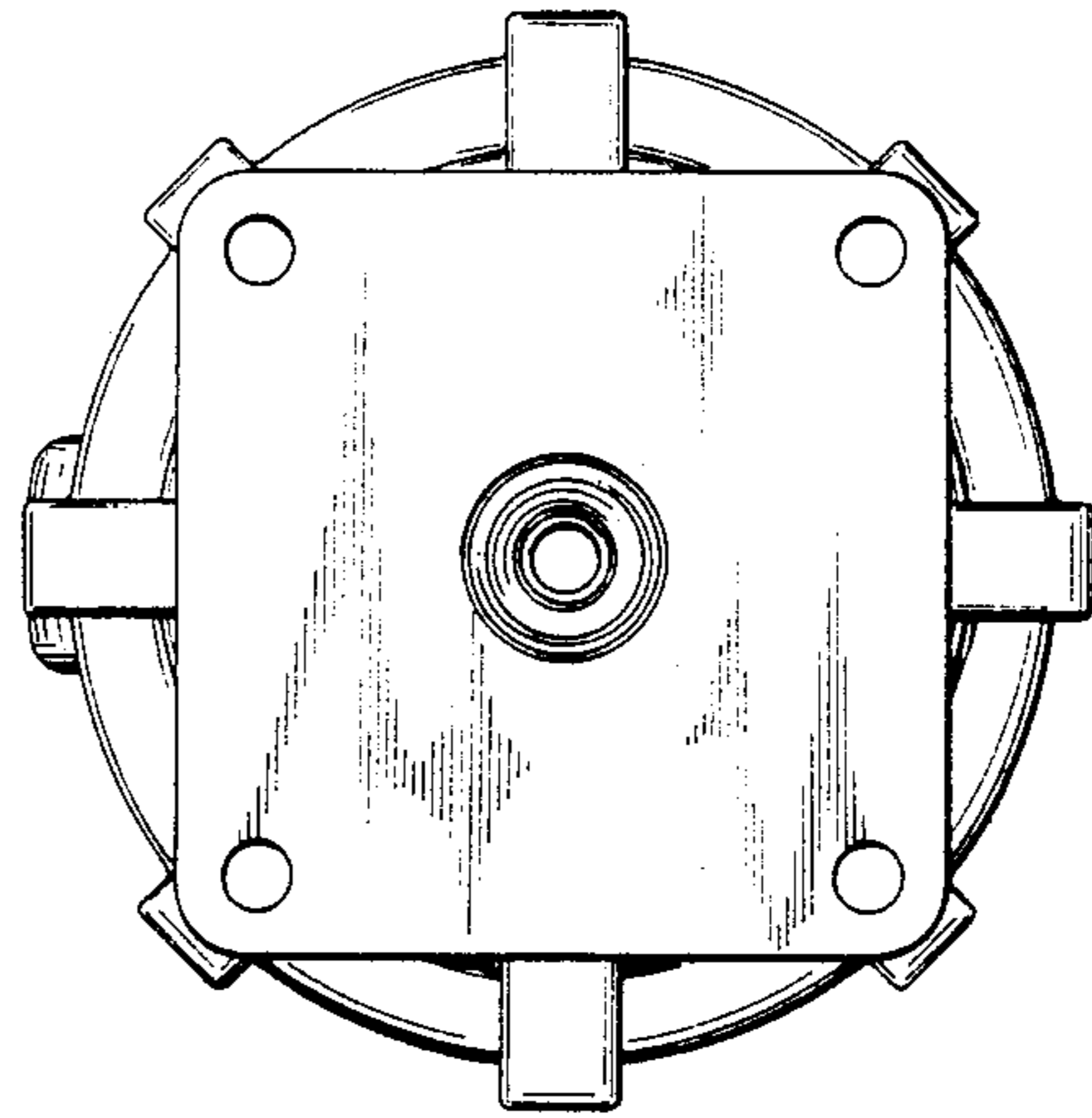

FIG. 7

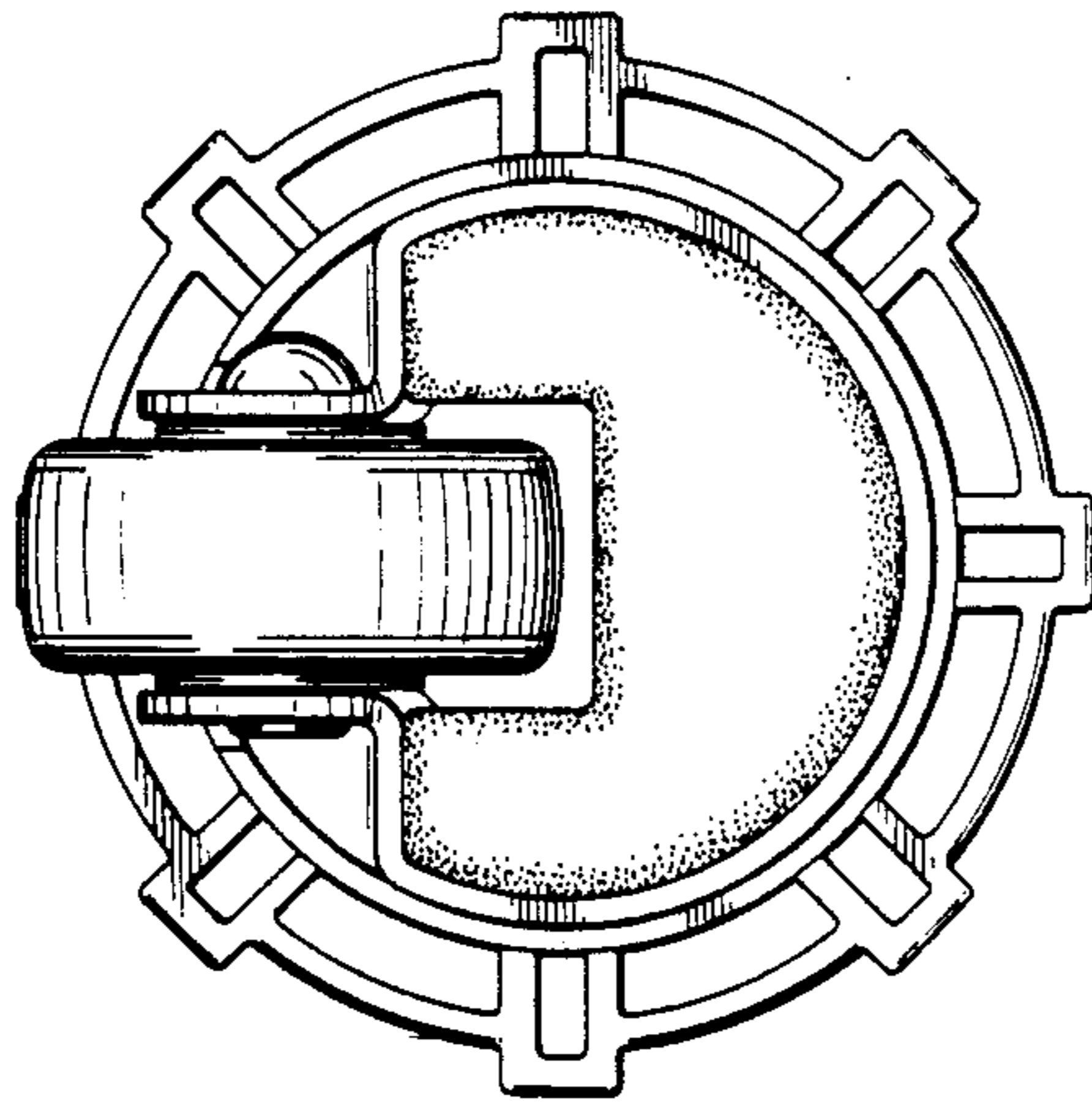

FIG. 8

