

United States Patent [19]

Garraffa

[11] Patent Number: **Des. 313,877**

[45] Date of Patent: **** Jan. 15, 1991**

[54] **FIRST STAGE SCUBA REGULATOR BOOT**

[75] Inventor: **Dean R. Garraffa**, Garden Grove, Calif.

[73] Assignee: **Under Sea Industries, Inc.**, Rancho Dominguez, Calif.

[**] Term: **14 Years**

[21] Appl. No.: **159,030**

[22] Filed: **Feb. 22, 1988**

[52] U.S. Cl. **D29/6**

[58] Field of Search 137/381, 382, 505.28, 137/505.42, 81.2; D23/230-235; D29/6-7

[56] **References Cited**

U.S. PATENT DOCUMENTS

- D. 156,735 1/1950 Jacobsson D23/235
- D. 202,319 9/1965 Shugarmann D29/6
- D. 218,921 10/1970 Lecoco D29/6
- D. 283,740 5/1986 Wiesinger et al. D29/6

- 2,855,950 10/1958 Phillips 137/505.28
- 3,004,686 10/1961 McKee 137/505.28
- 3,212,516 10/1965 Natho 137/505.42
- 3,920,033 11/1975 Ferrando 137/505.42 X
- 4,226,257 10/1980 Trinkwalder 137/81.2

Primary Examiner—Louis S. Zarfes
Assistant Examiner—Demetrius Reynolds
Attorney, Agent, or Firm—Leonard Tachner

[57] **CLAIM**

The ornamental design for a first stage scuba regulator boot, as shown and described.

DESCRIPTION

FIG. 1 is a top perspective view of a first stage scuba regulator boot showing my new design;
FIG. 2 is a top plan view thereof;
FIG. 3 is a bottom plan view thereof;
FIG. 4 is a front elevational view thereof;
FIG. 5 is a rear elevational view thereof; and
FIG. 6 is a right side elevational view thereof, the left side being a mirror image of the right side shown.

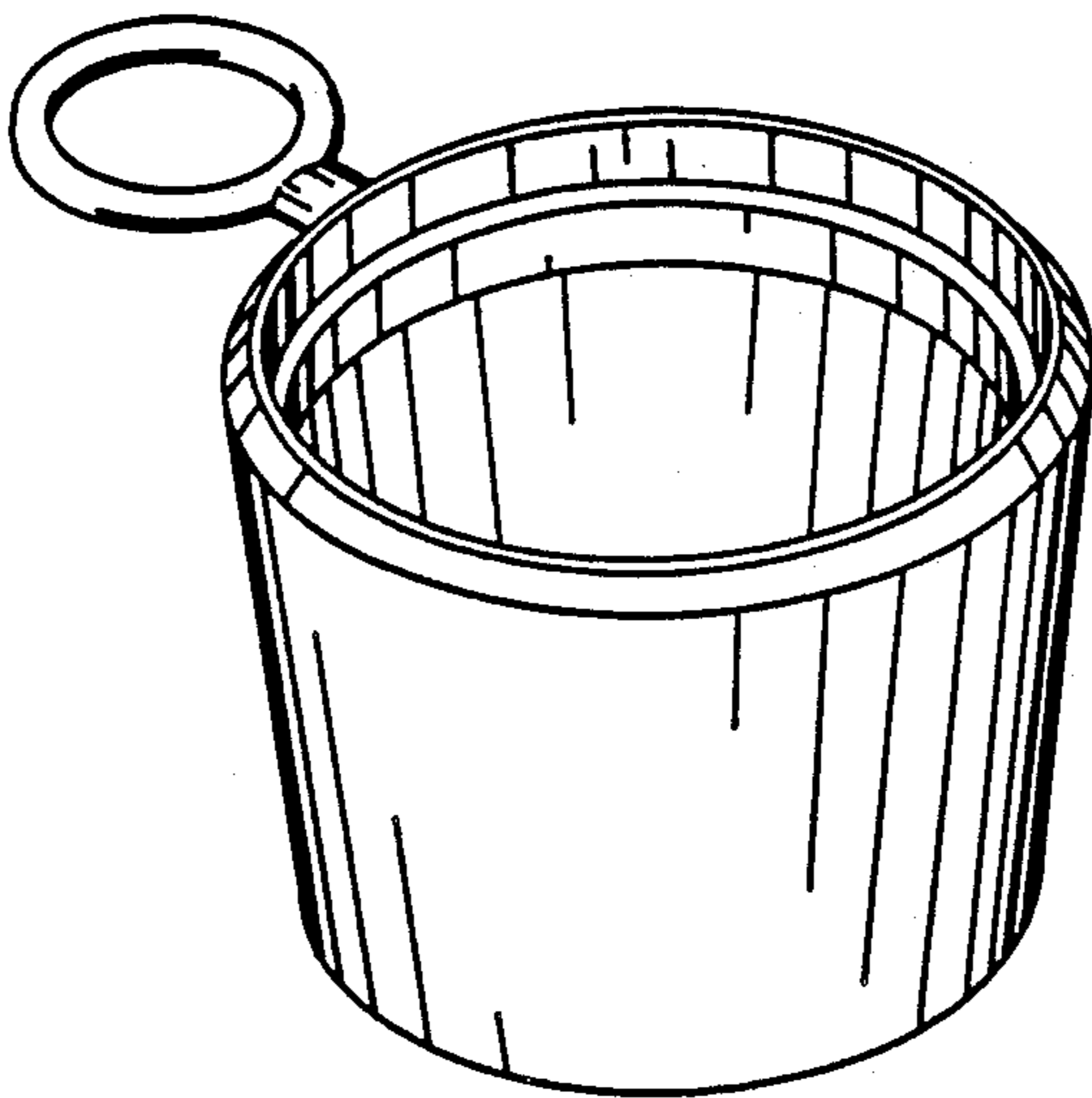

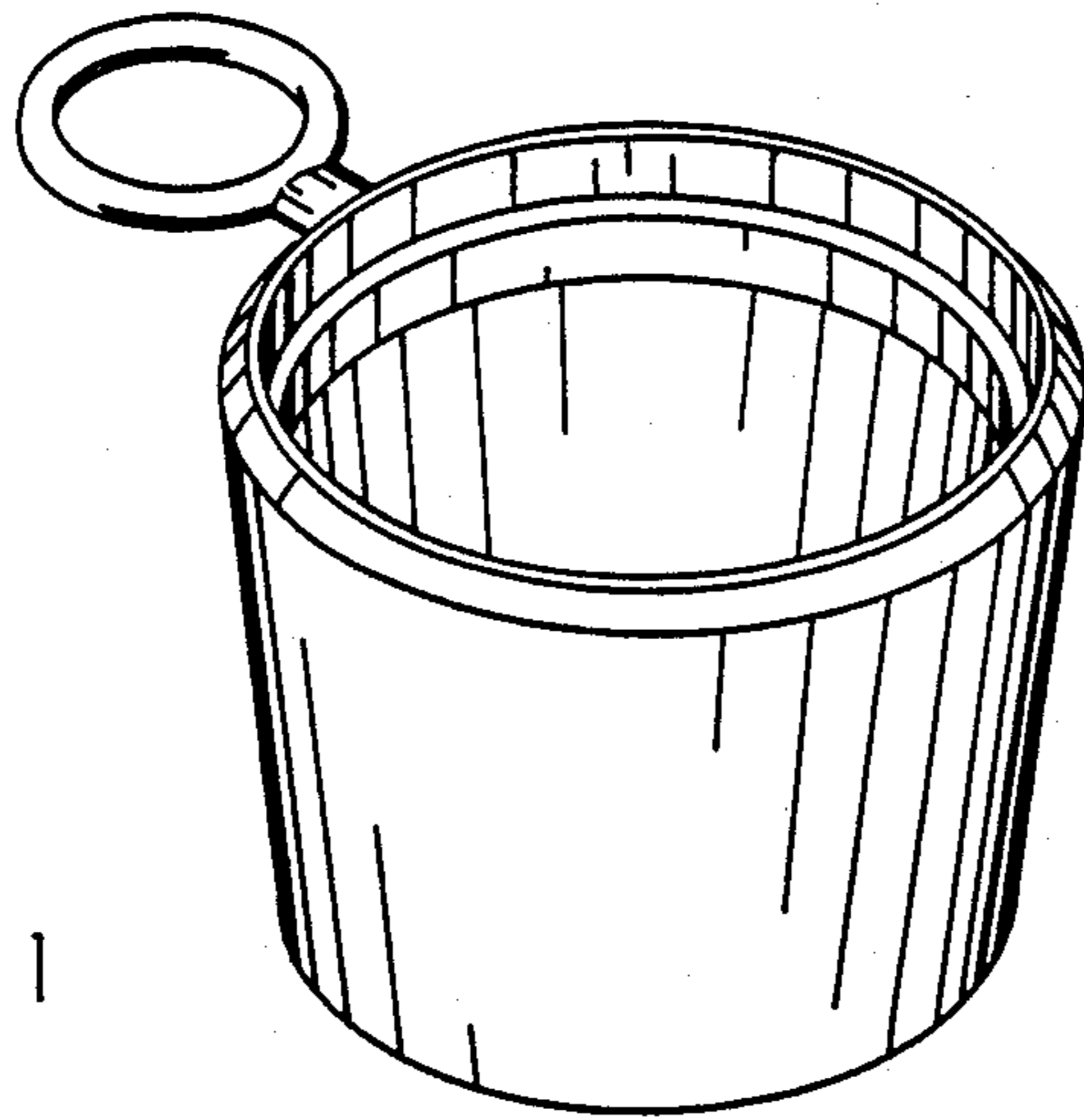

FIG. 1

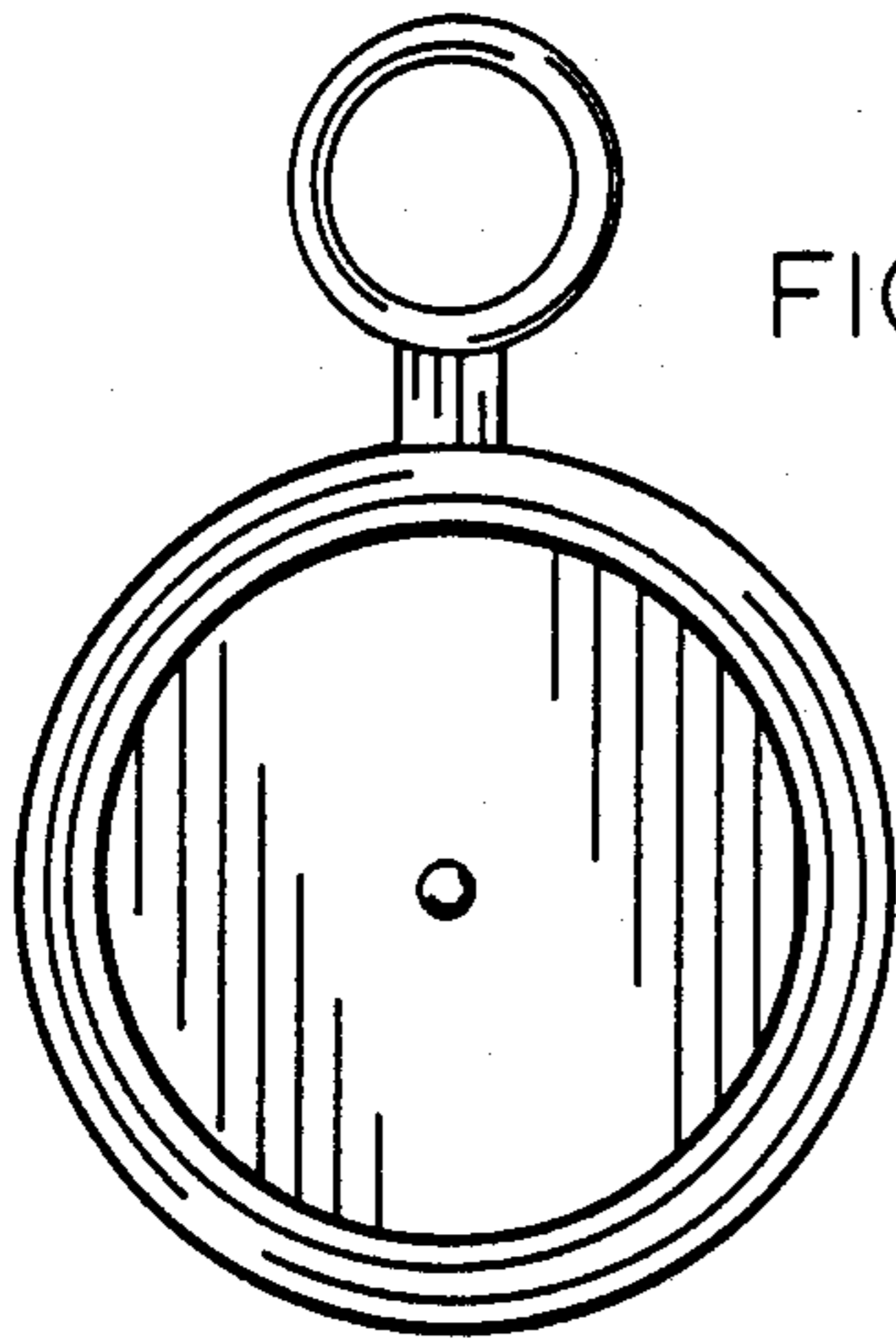

FIG. 2

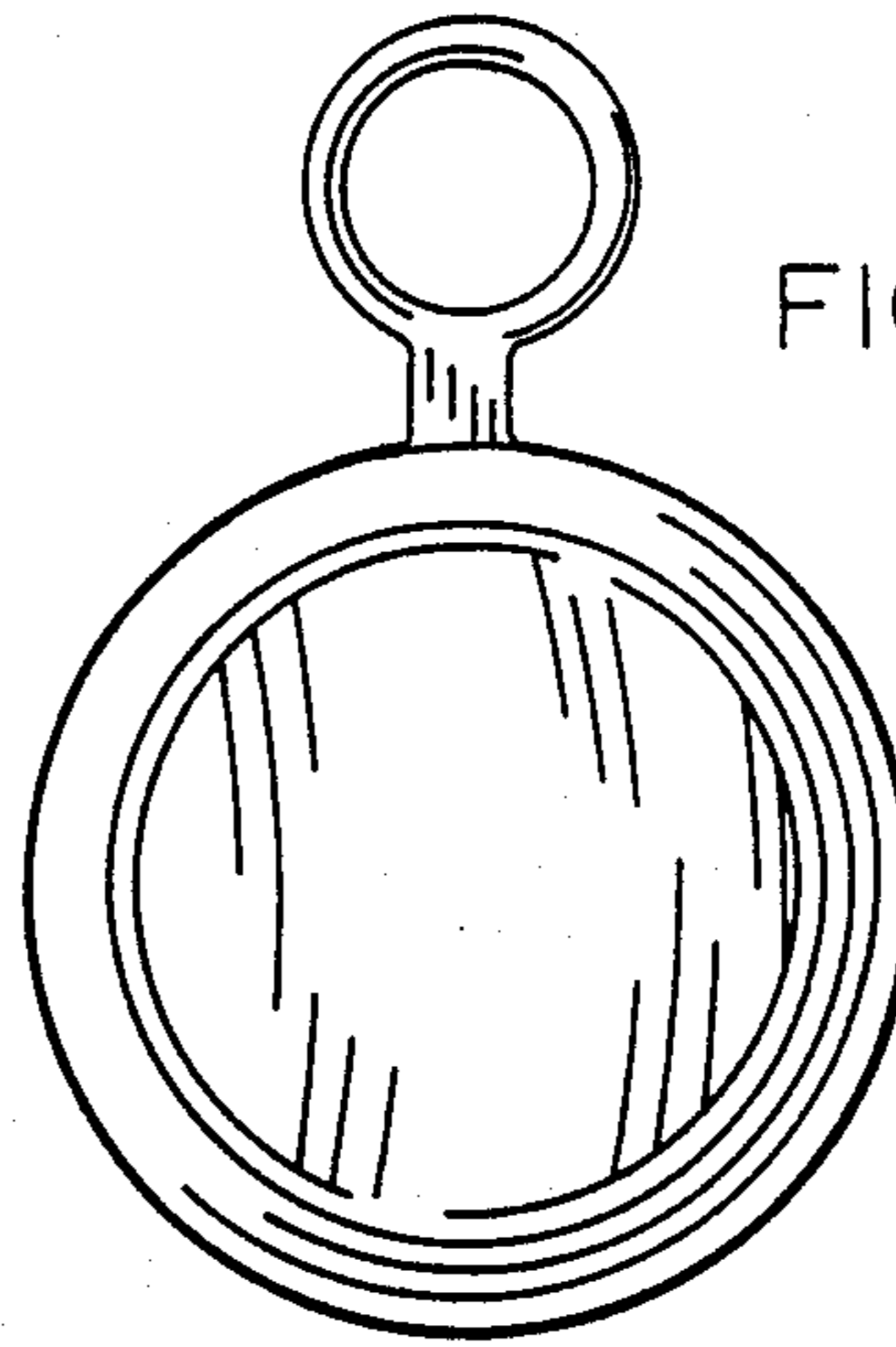

FIG. 3

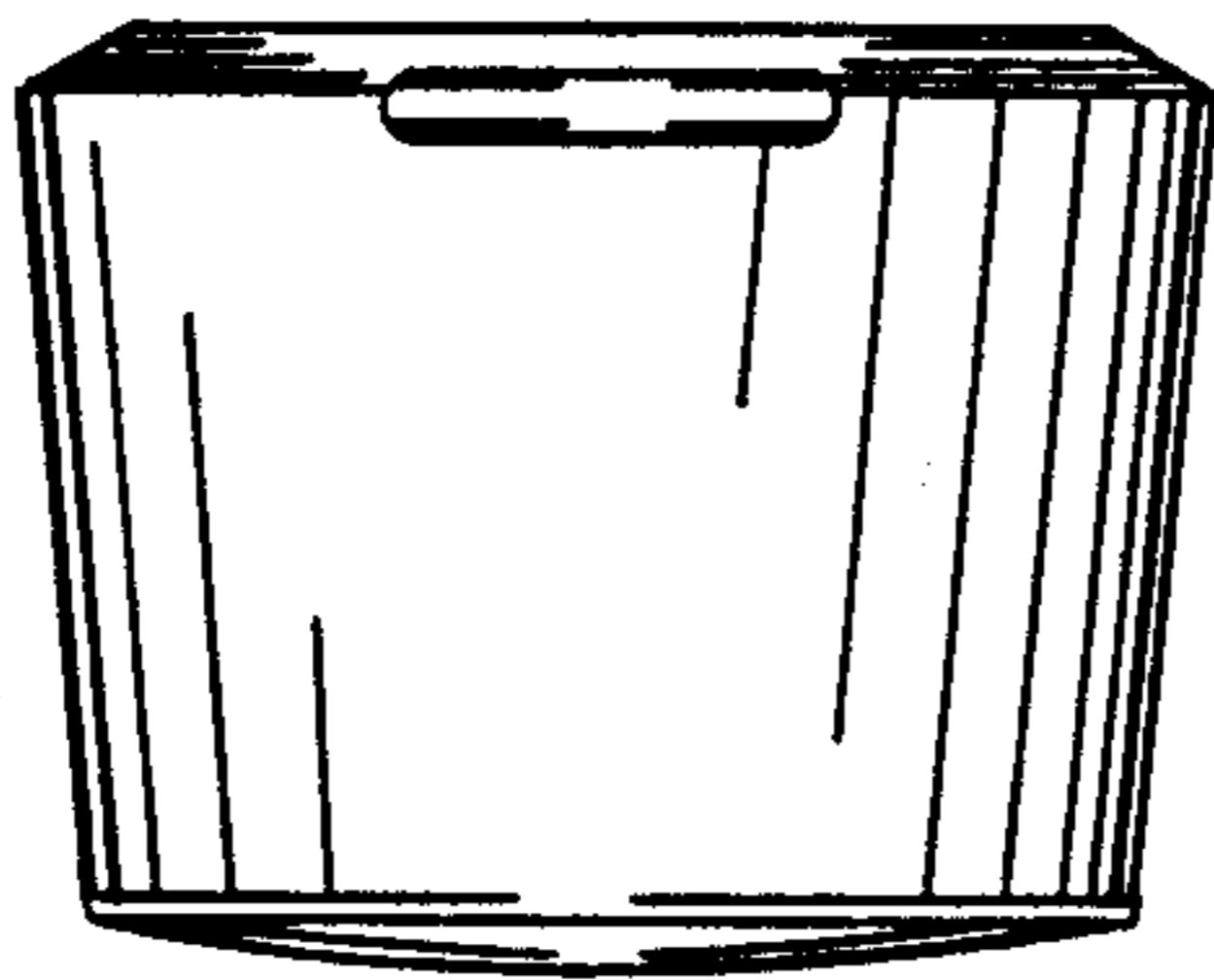

FIG. 4

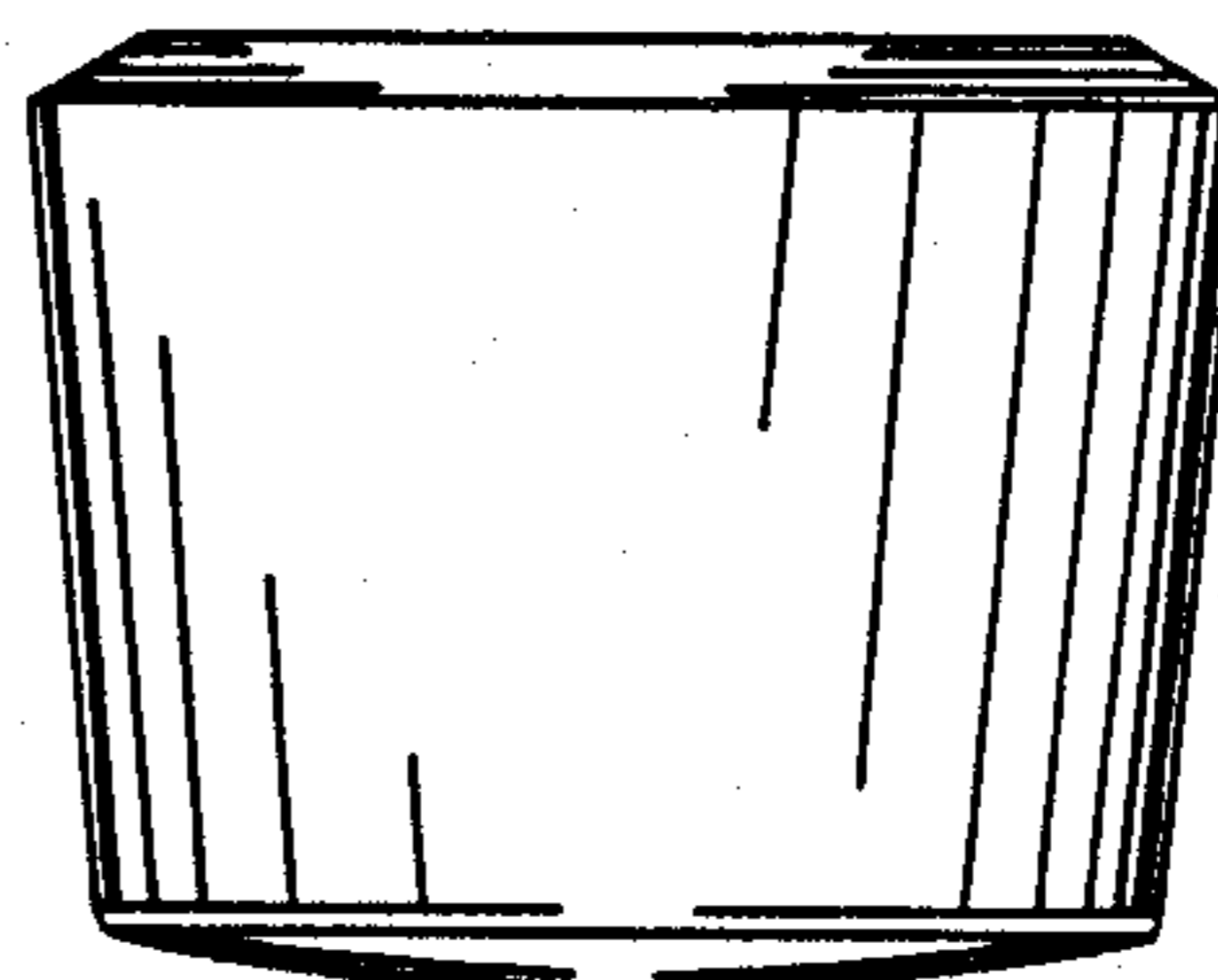

FIG. 5

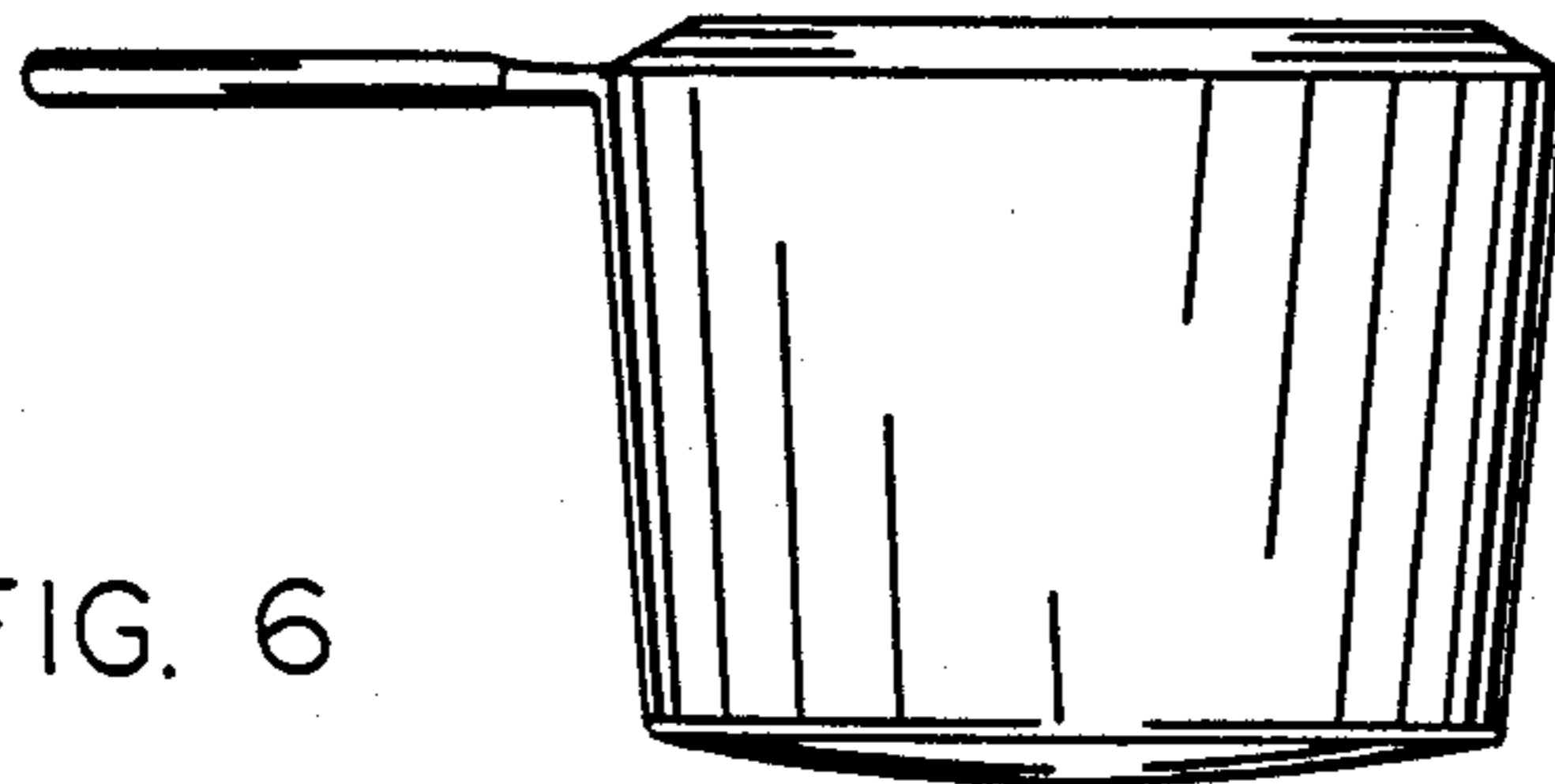

FIG. 6