

[54] **MANIFOLD FOR ANGIOPLASTY BALLOON CATHETER**

[75] **Inventor: David B. Robinson, Chanhassen, Minn.**

[73] **Assignee: SciMed Life Systems, Inc., Maple Grove, Minn.**

[**] **Term: 14 Years**

[21] **Appl. No.: 173,755**

[22] **Filed: Mar. 24, 1988**

[52] **U.S. Cl. D24/53**

[58] **Field of Search D24/53; 604/96, 99, 604/101, 165, 285; 606/194, 195; 128/657**

[56] **References Cited**

U.S. PATENT DOCUMENTS

D. 297,367	8/1988	Miyasaka et al.	D24/53
4,195,637	4/1980	Grüntzig et al.	128/348
4,332,254	6/1982	Lundquist	128/344
4,582,181	4/1986	Samson	128/348.1
4,641,654	2/1987	Samson et al.	128/344
4,646,742	3/1987	Packard et al.	128/344
4,655,746	4/1987	Daniels et al.	604/53
4,664,113	5/1987	Frisbie et al.	128/344
4,730,616	3/1988	Frisbie et al.	128/348
4,753,238	6/1988	Gaiser	606/195
4,771,776	9/1988	Powell et al.	606/194
4,846,174	7/1989	Willard et al.	606/194

FOREIGN PATENT DOCUMENTS

86/06285 11/1986 PCT Int'l Appl. .

OTHER PUBLICATIONS

SciMed Life Systems, Inc., "Angioplasty," Publication No. IMPMP 11-86 (1986).

Versaflex Delivery Systems, Inc., "Flexibility, Trackability, Pushability, and Low-Profile Coiled Into One," 1988 brochure distributed by Medtronic (Minneapolis, MN 55432).

C. R. Bard, Inc., Catalog, "PTCA Accessories," showing Disposable PTCA Y-Adapters, catalog No. 006055, p. 13.

Primary Examiner—A. Hugo Word

Assistant Examiner—Stella M. Reid

Attorney, Agent, or Firm—Kinney & Lange

[57] **CLAIM**

The ornamental design for a manifold for angioplasty balloon catheter, as shown and described.

DESCRIPTION

FIG. 1 is a perspective view of a manifold for angioplasty balloon catheter, showing our new design; FIG. 2 is a side elevational view thereof; FIG. 3 is a side elevational view thereof, opposite that shown in FIG. 2; FIG. 4 is a top plan view thereof; FIG. 5 is a bottom plan view thereof; FIG. 6 is a front elevational view thereof; FIG. 7 is a rear elevational view thereof; FIG. 8 is a perspective view of a second embodiment of FIG. 1; FIG. 9 is a side elevational view thereof; FIG. 10 is a side elevational view thereof, opposite that shown in FIG. 9; FIG. 11 is a top plan view thereof; FIG. 12 is a bottom plan view thereof; FIG. 13 is a front elevational view thereof, and FIG. 14 is a rear elevational view thereof.

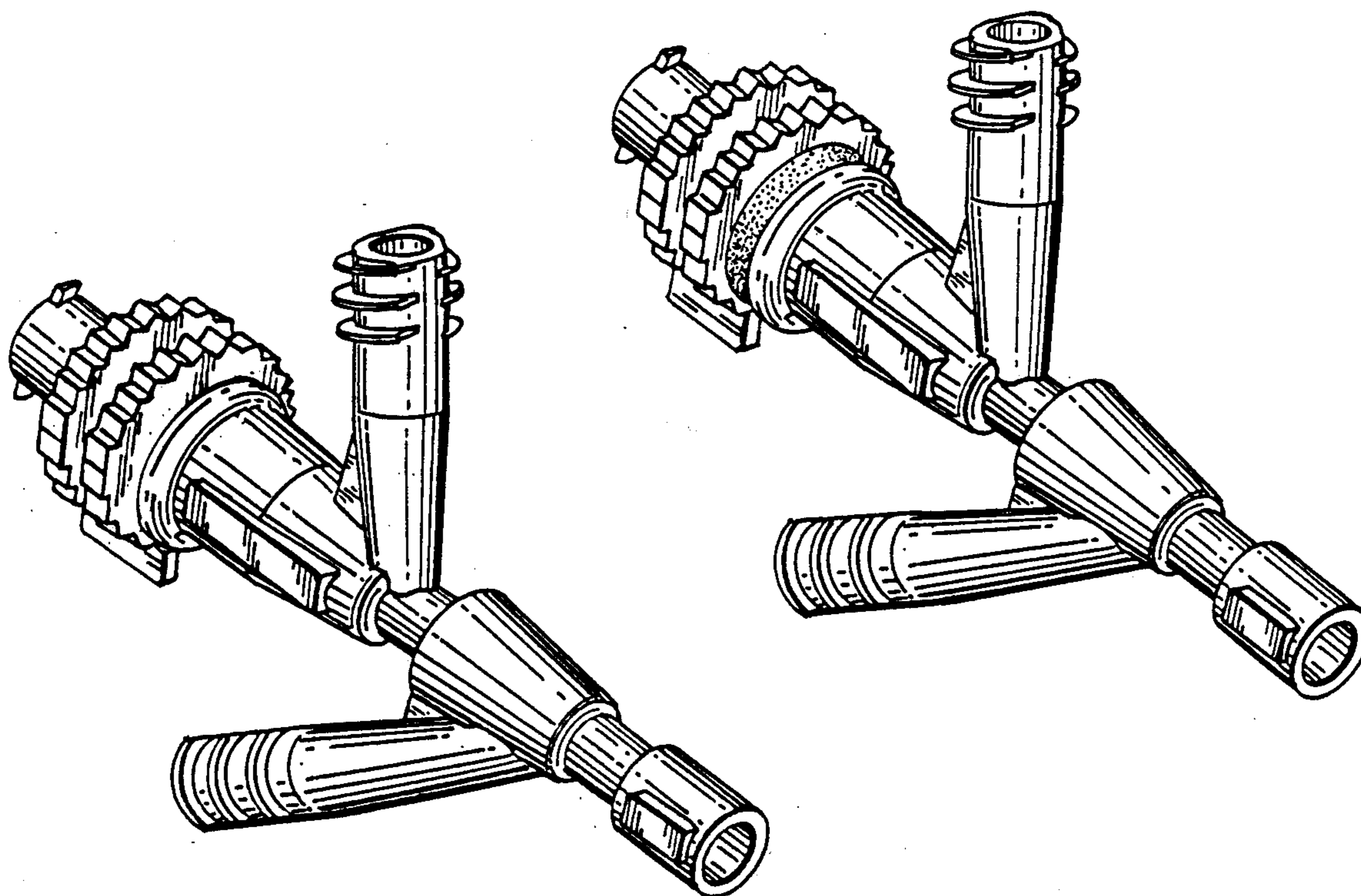

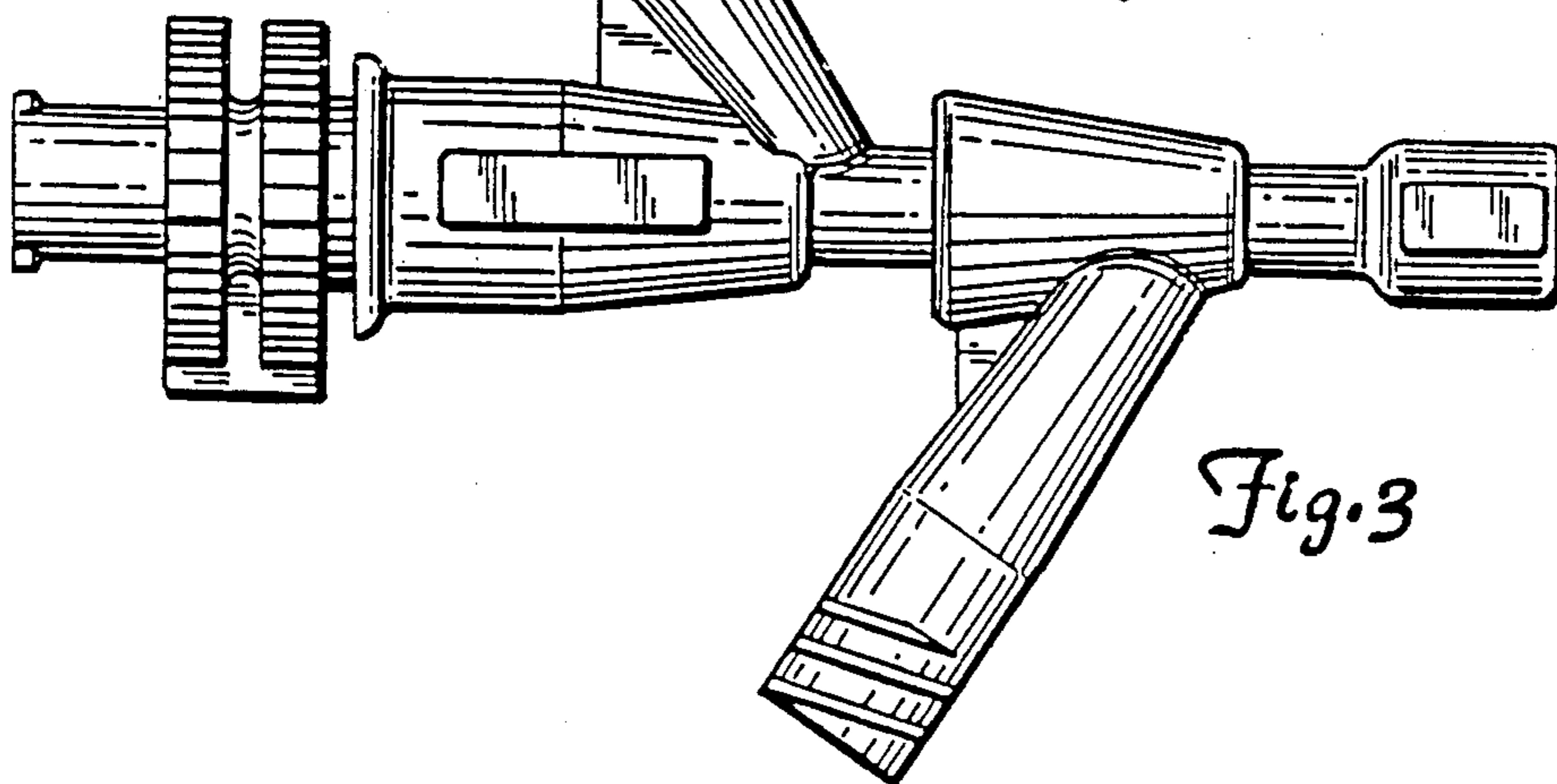
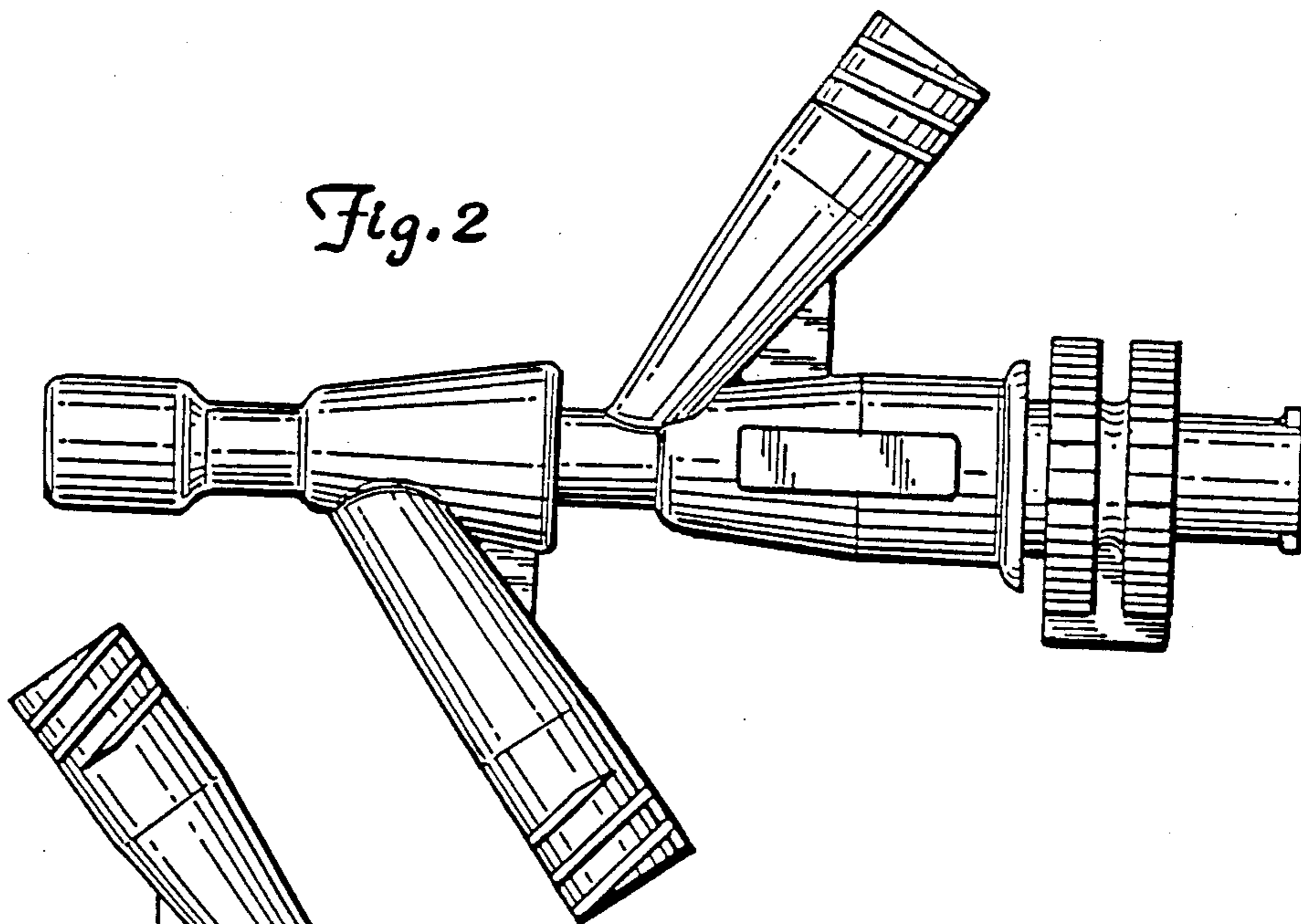
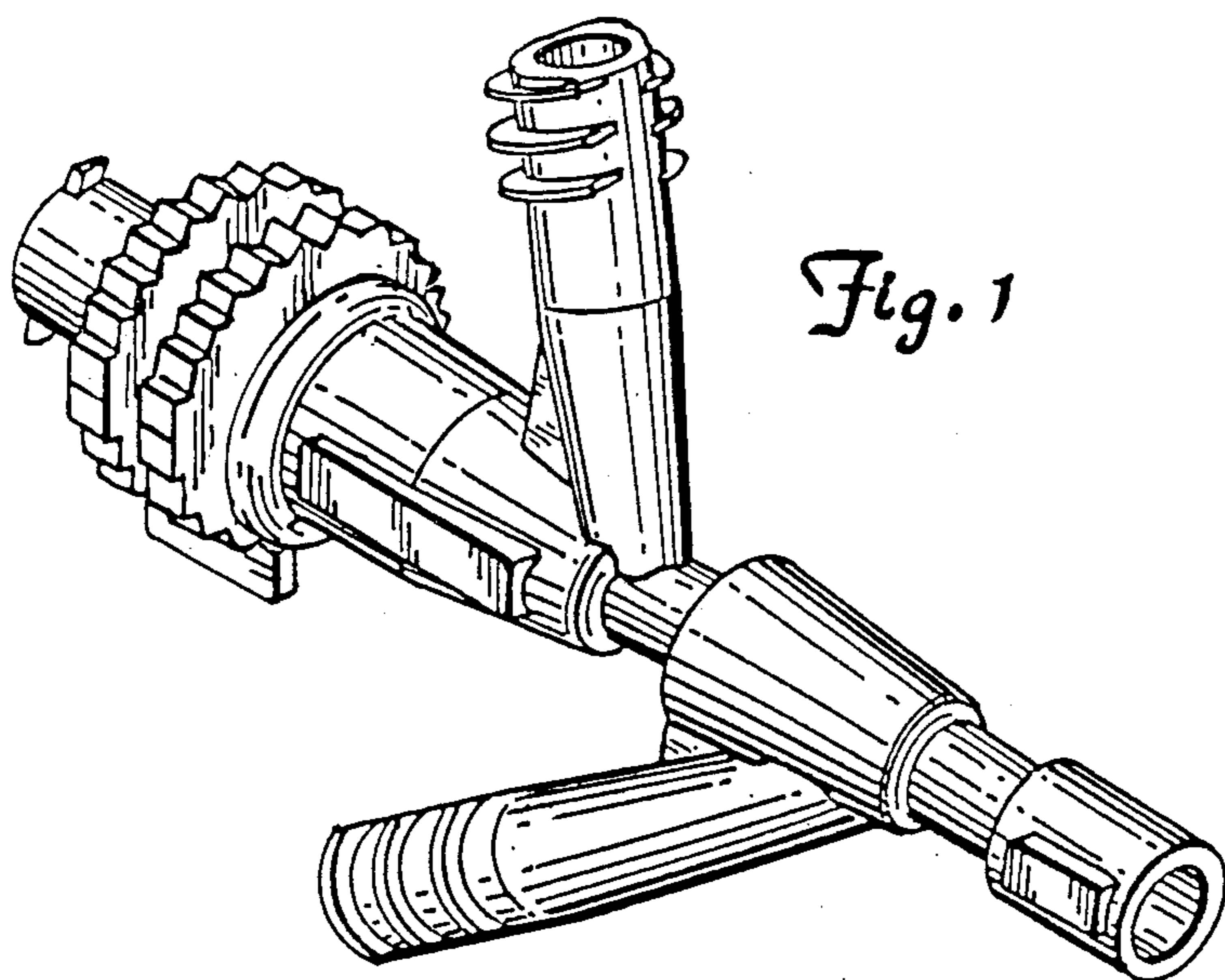

Fig. 4

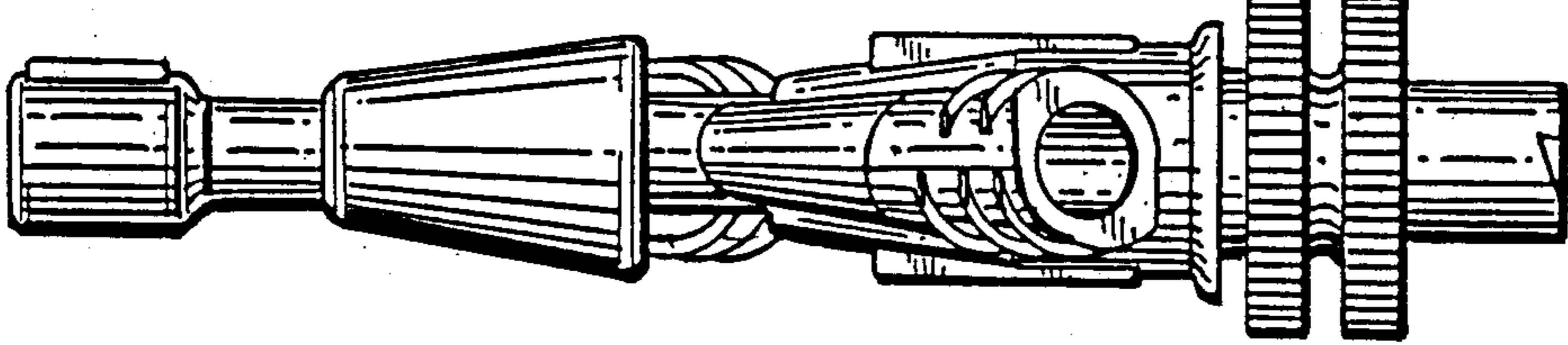

Fig. 5

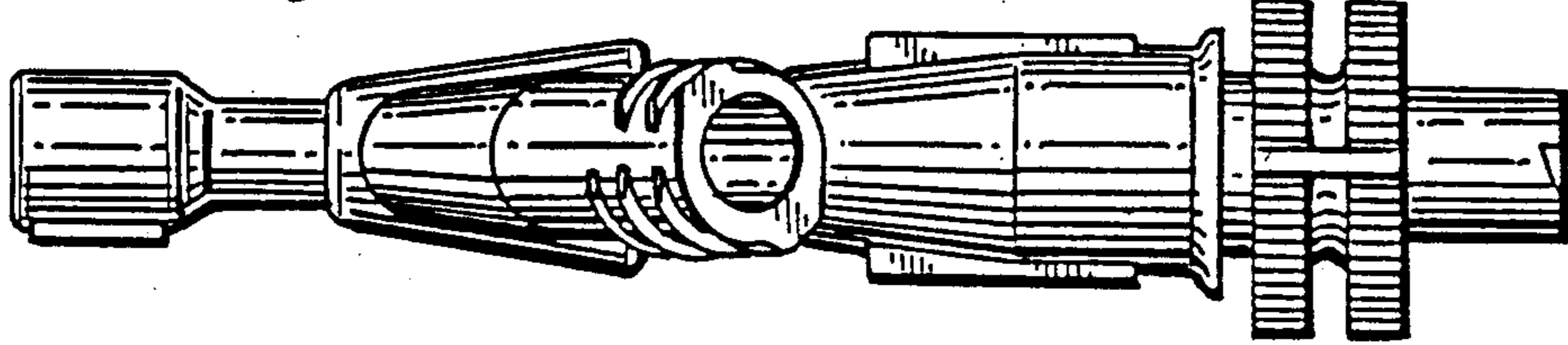

Fig. 6

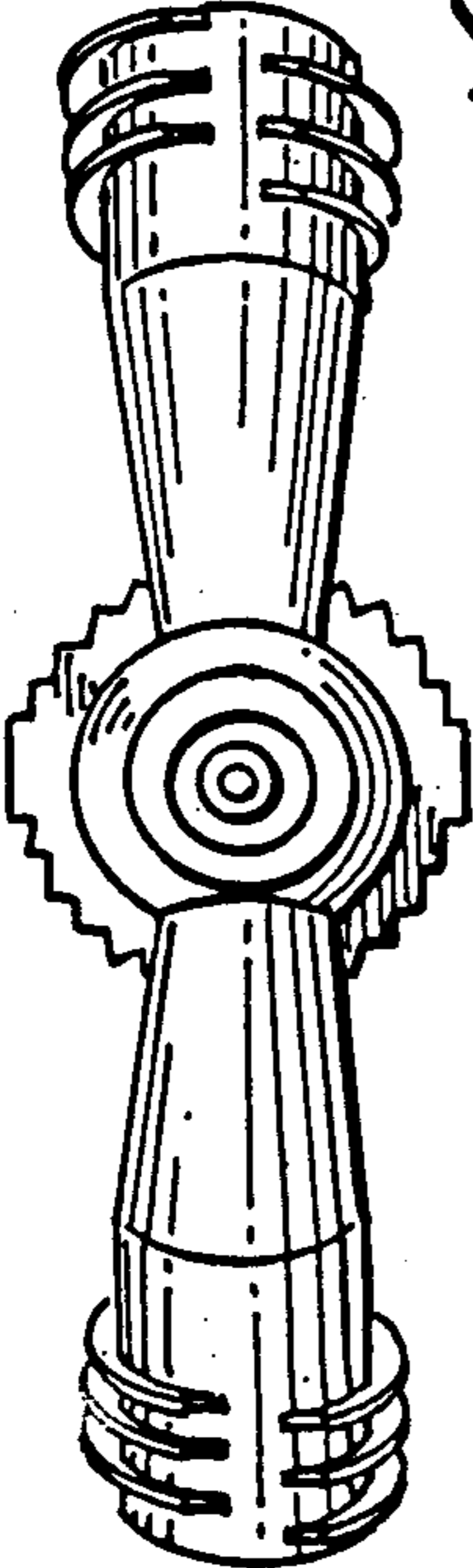
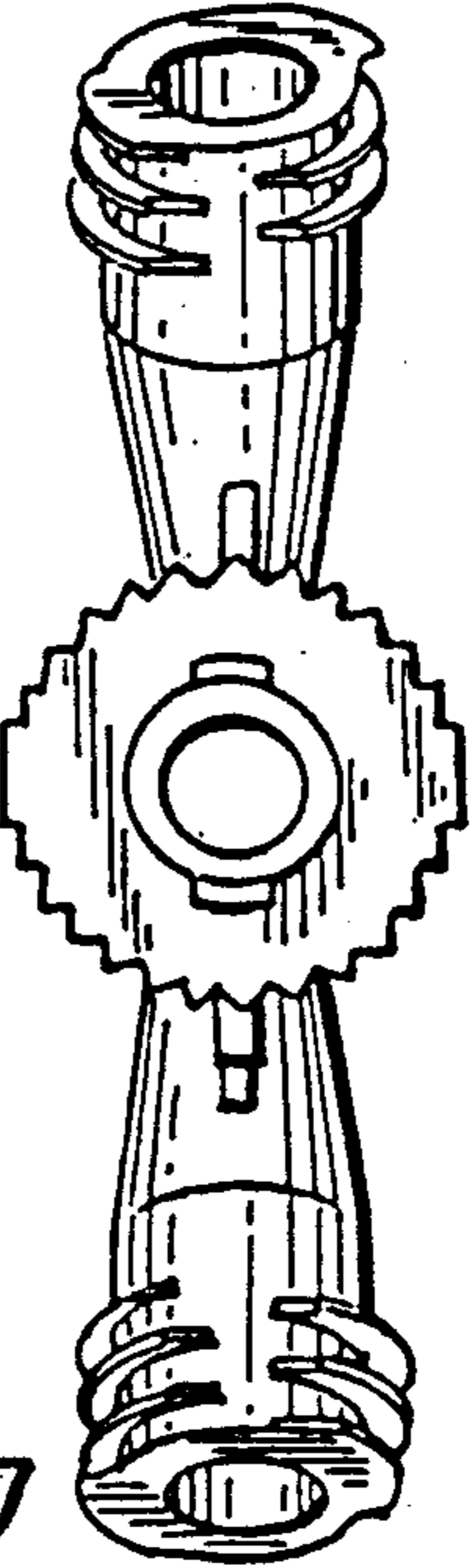

Fig. 7



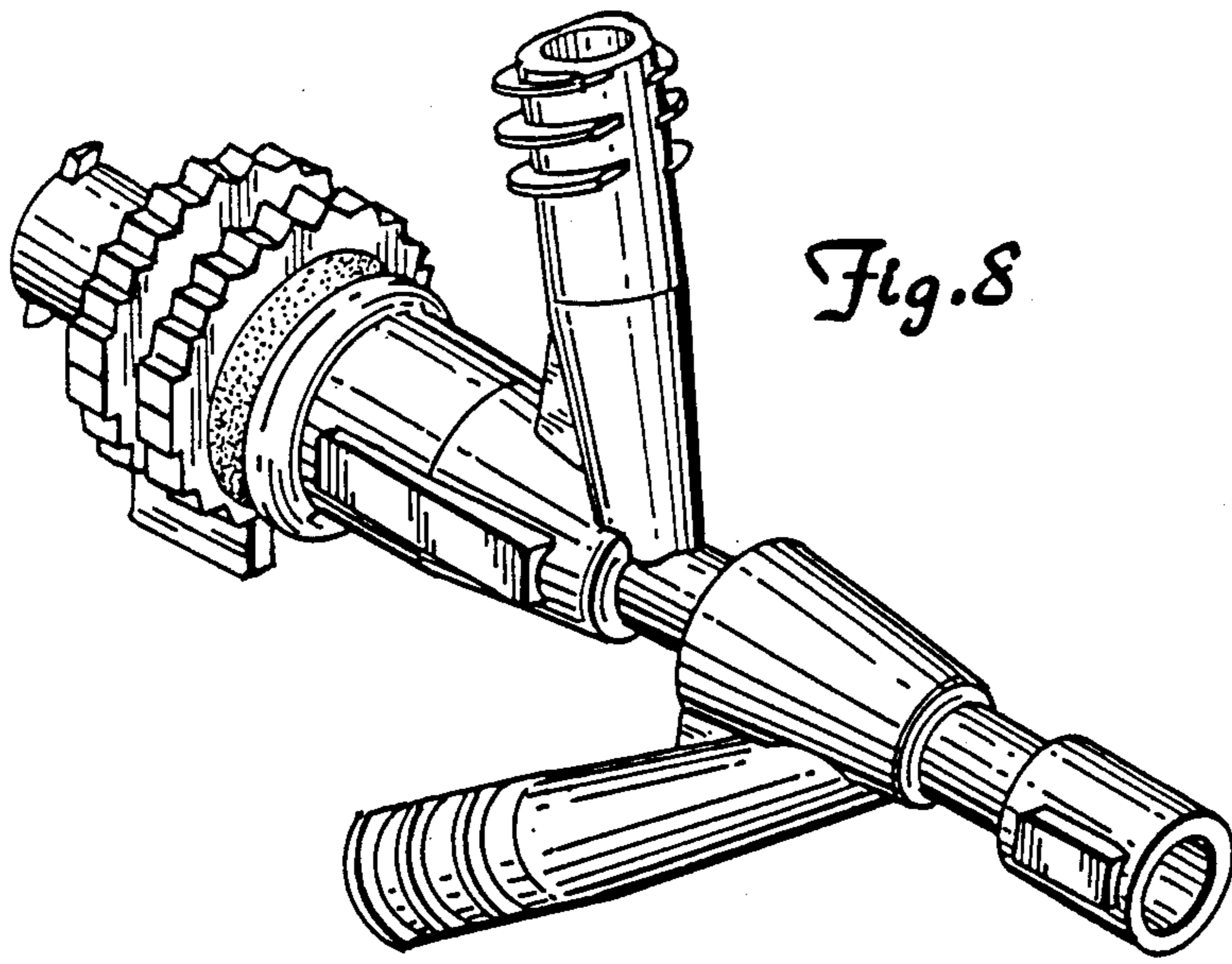

Fig. 8

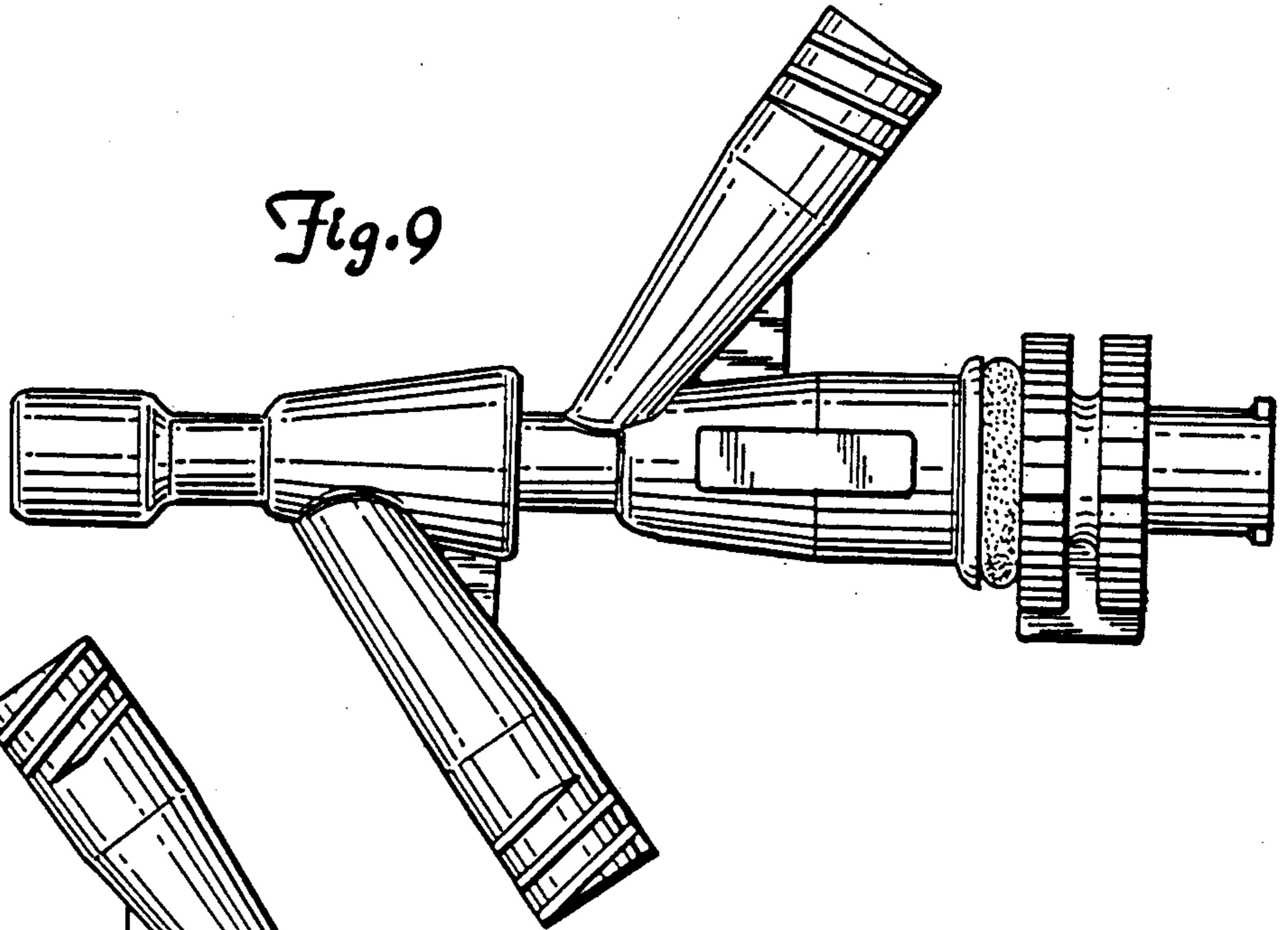

Fig. 9

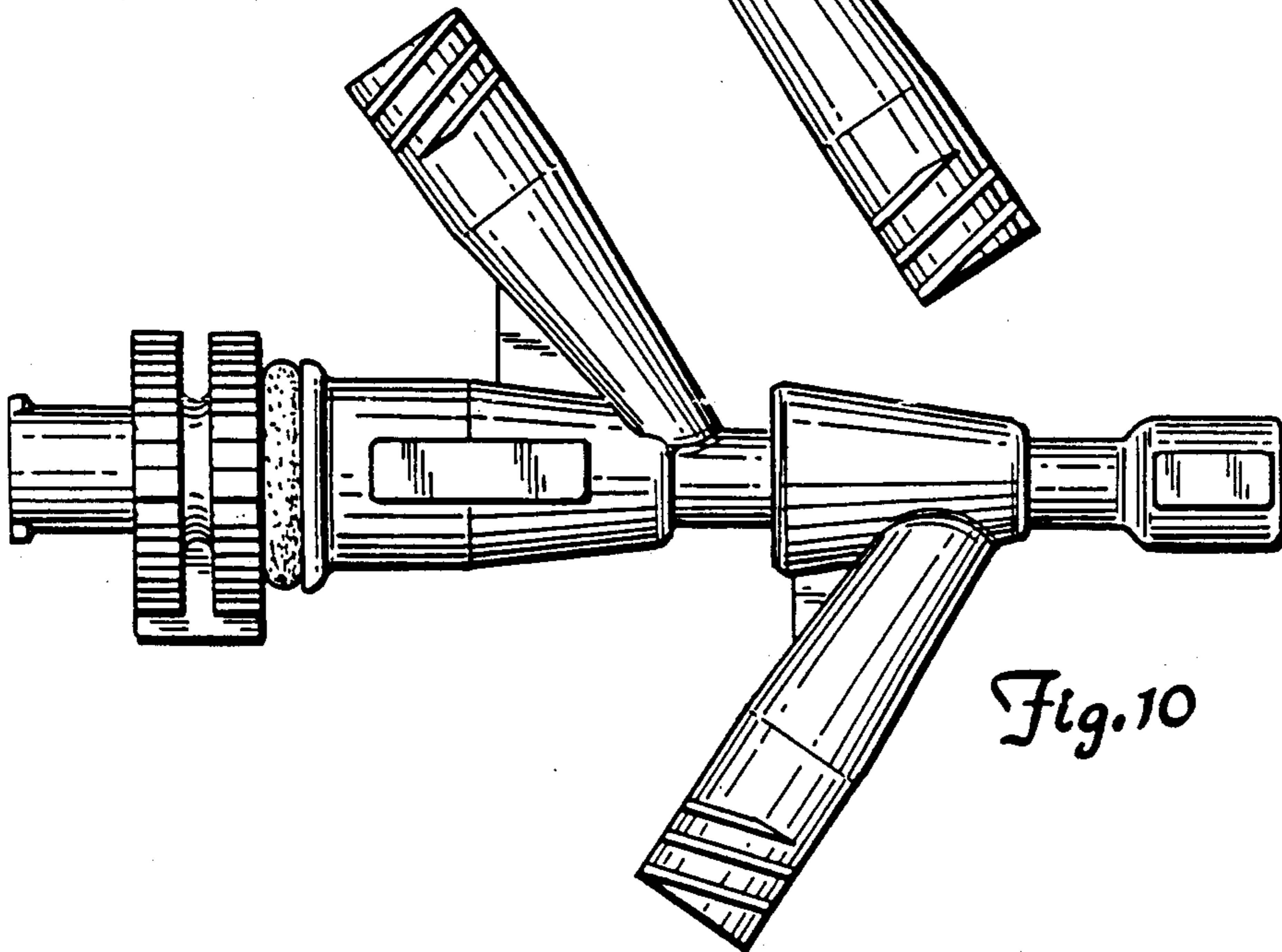

Fig. 10

Fig. 11

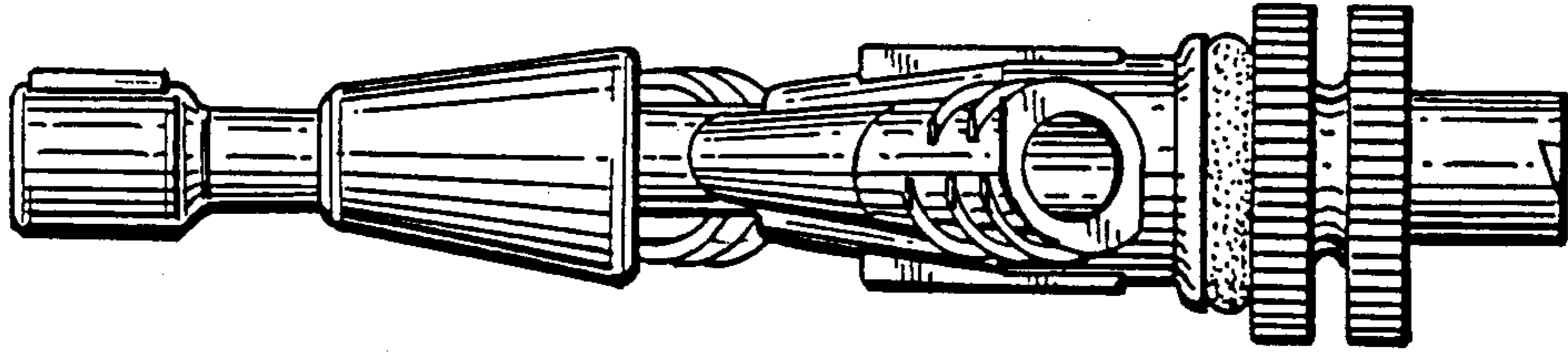

Fig. 12

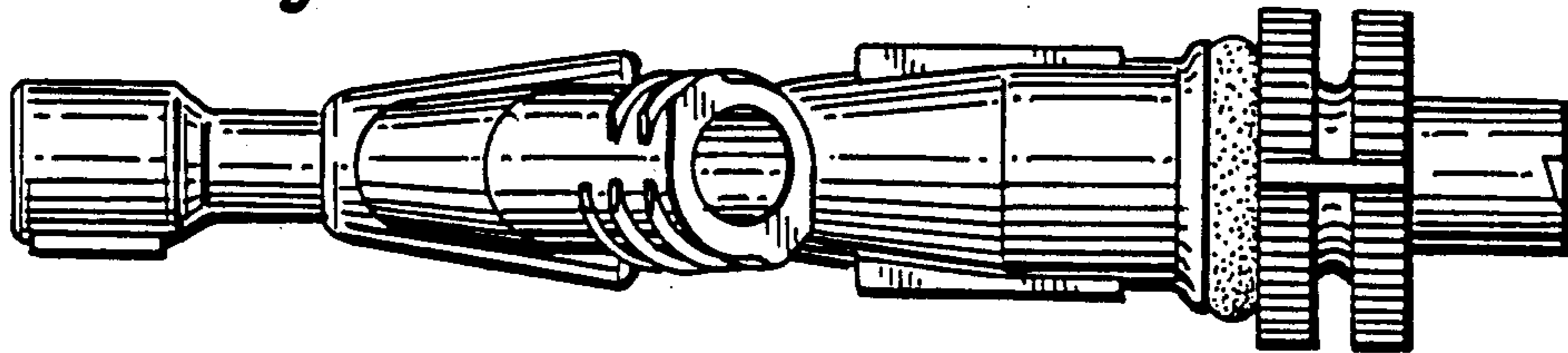

Fig. 13

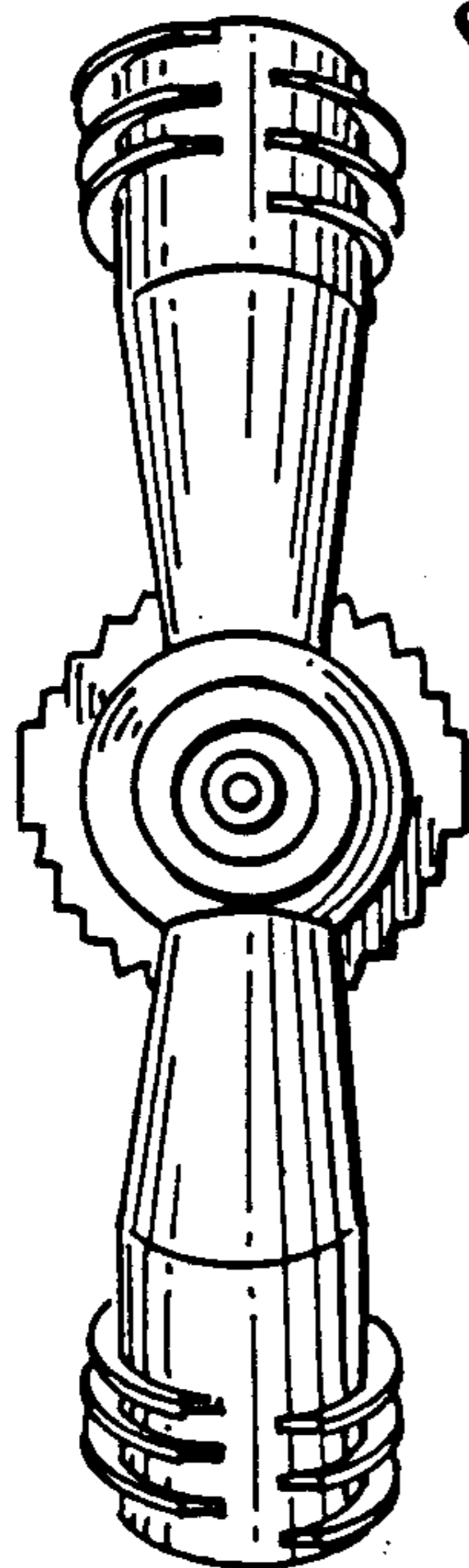

Fig. 14

