

[54] TOY RAILROAD FREIGHT CAR

[75] Inventor: Herbert C. Weiland, Rancho Palos Verdes, Calif.

[73] Assignee: Clover Toys, Inc., LaMirada, Calif.

[**] Term: 14 Years

[21] Appl. No.: 208,543

[22] Filed: Jun. 20, 1988

[52] U.S. Cl. D21/129; D21/141

[58] Field of Search D21/59, 108, 114, 129, D21/134, 141; 446/85, 88, 93, 103, 108, 115, 124

[56] References Cited

U.S. PATENT DOCUMENTS

- D. 24,263 4/1895 Ives D21/129
- D. 25,722 6/1896 Ives D21/129
- D. 30,155 2/1899 Kingsbury D21/129

- D. 30,377 3/1899 Kingsbury D21/129
- D. 31,374 8/1899 Harris D21/129
- D. 190,999 8/1961 Mykleby D21/129
- D. 258,457 3/1981 Pape D21/133

Primary Examiner—Charles A. Rademaker
Assistant Examiner—Alicia A. Farrell
Attorney, Agent, or Firm—G. Donald Weber, Jr.

[57] CLAIM

The ornamental design for a toy railroad freight car, as shown and described.

DESCRIPTION

FIG. 1 is a perspective view of a toy railroad freight car showing my new design;
FIG. 2 is a top plan view thereof;
FIG. 3 is a bottom plan view thereof;
FIG. 4 is a side elevational view thereof, the side opposite being a mirror image;
FIG. 5 is a front elevational view thereof; and
FIG. 6 is a rear elevational view thereof.

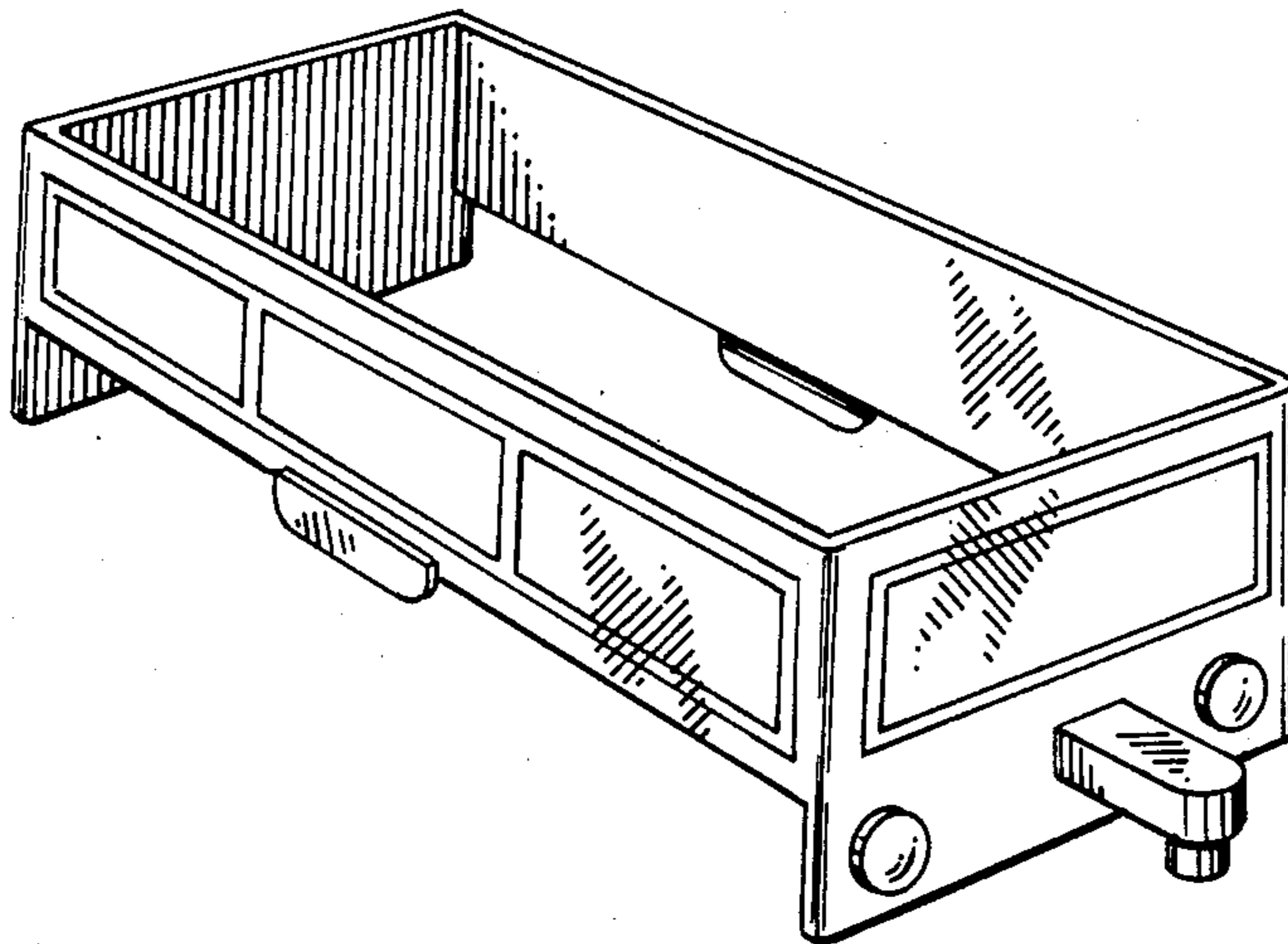

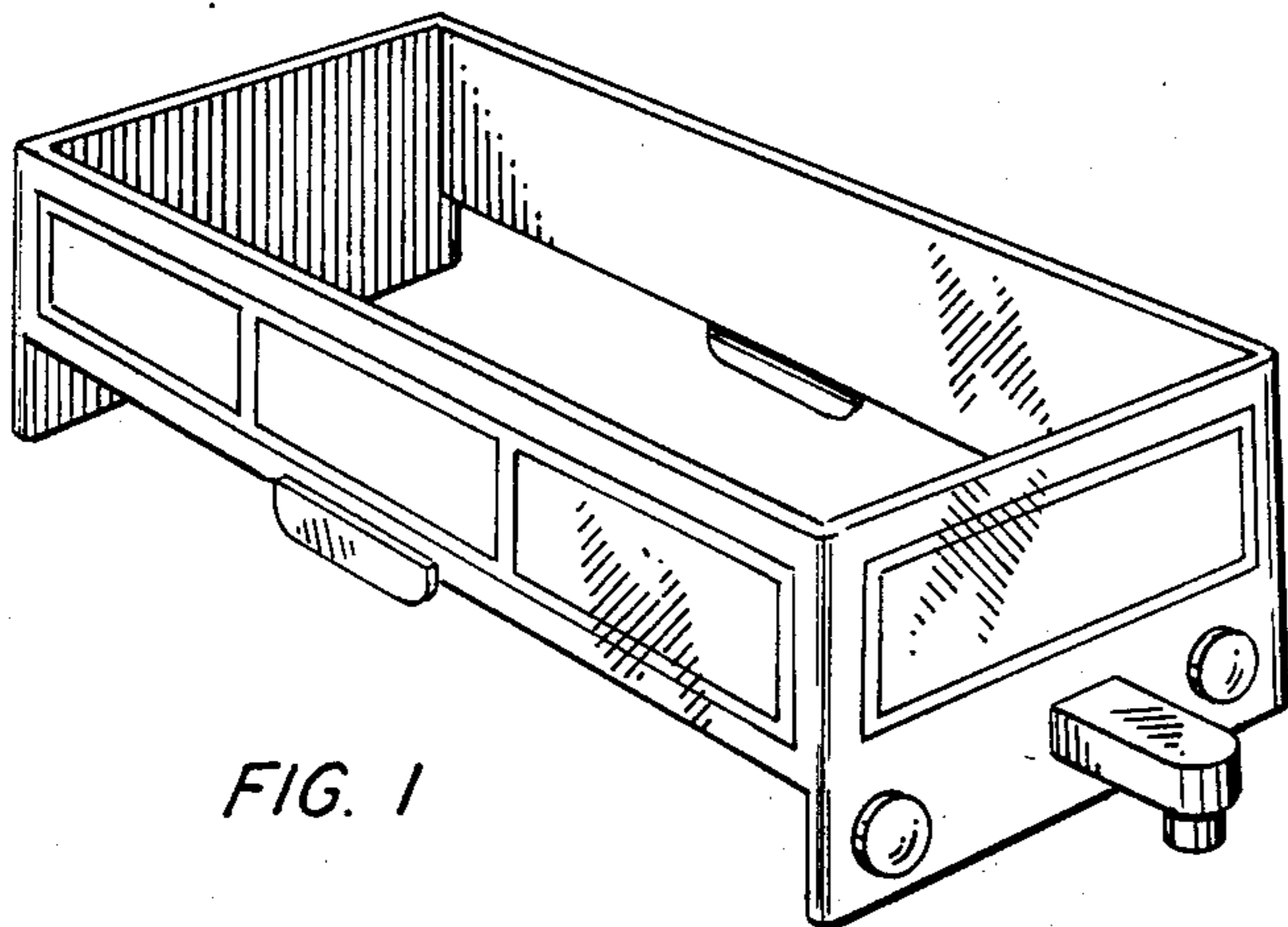

FIG. 1

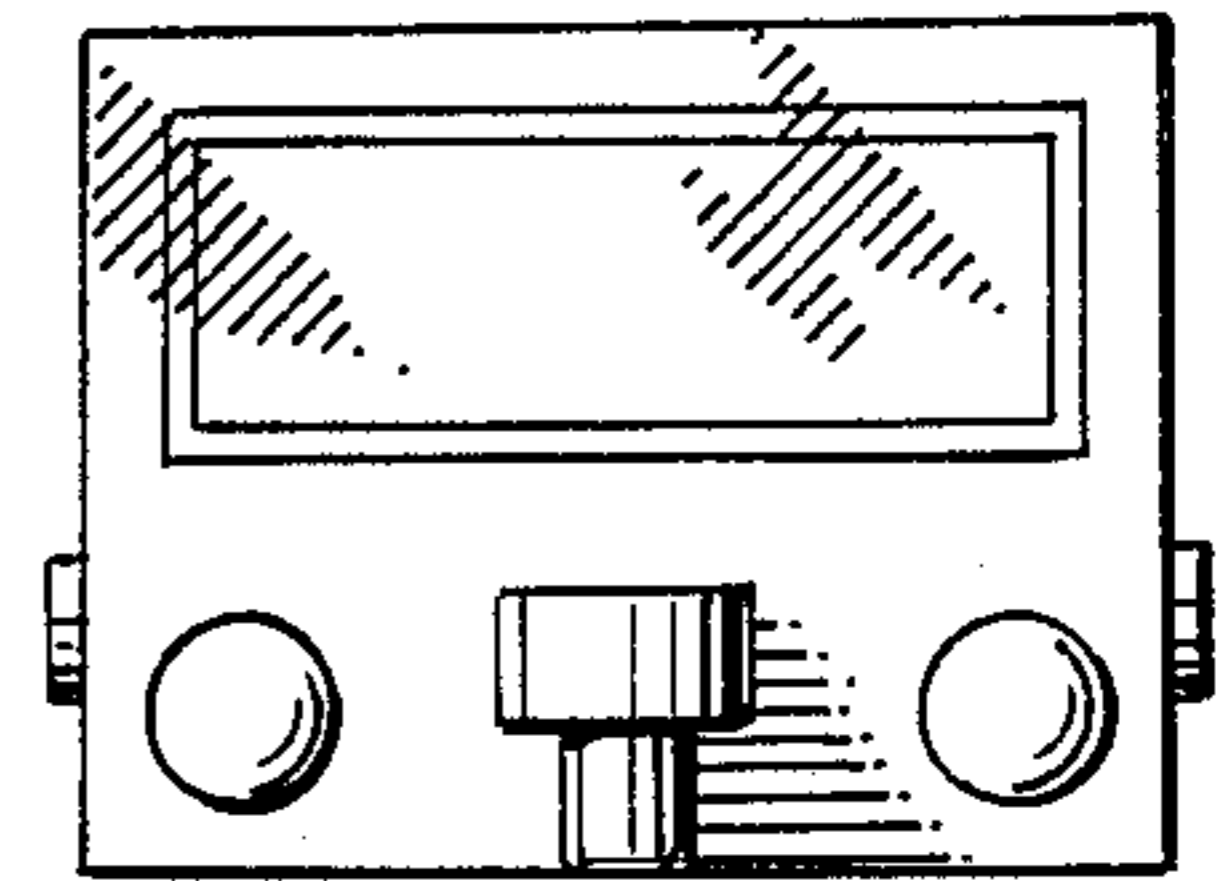

FIG. 5

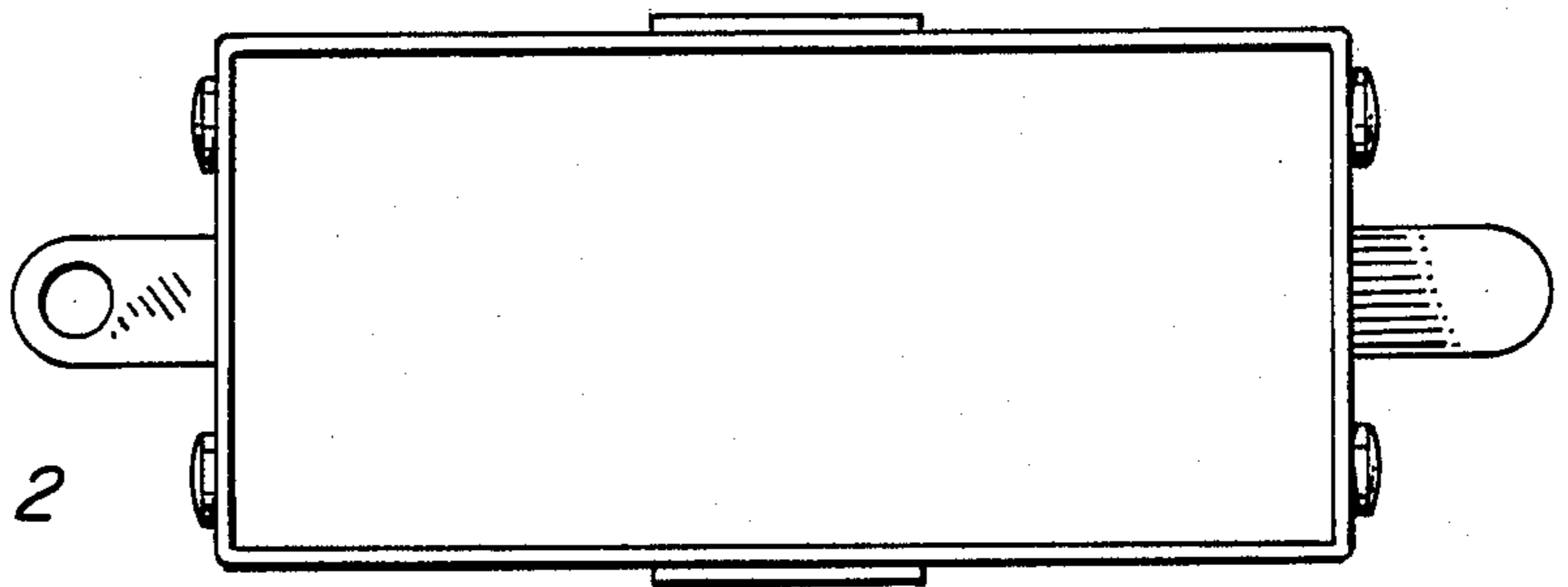

FIG. 2

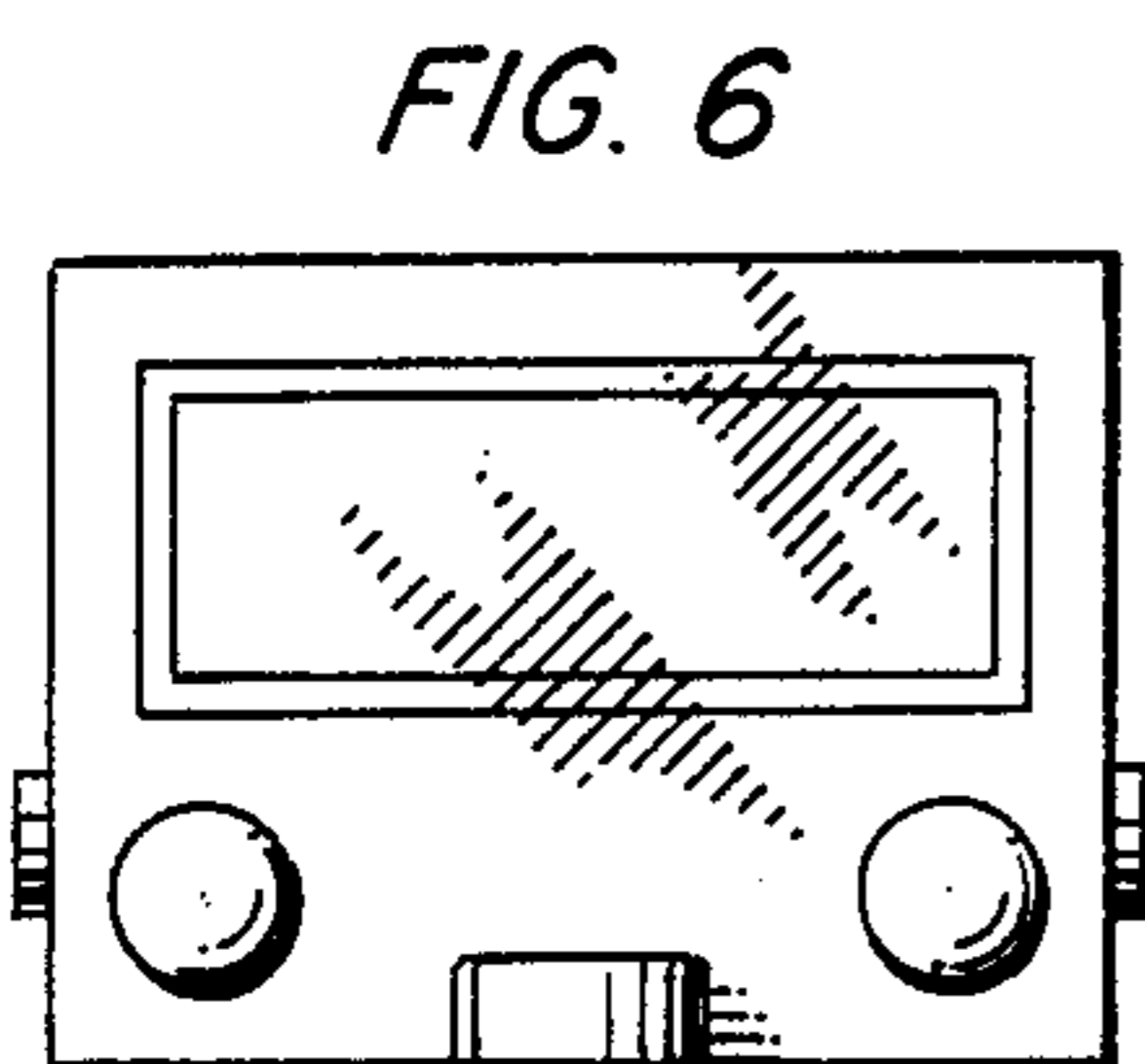

FIG. 6

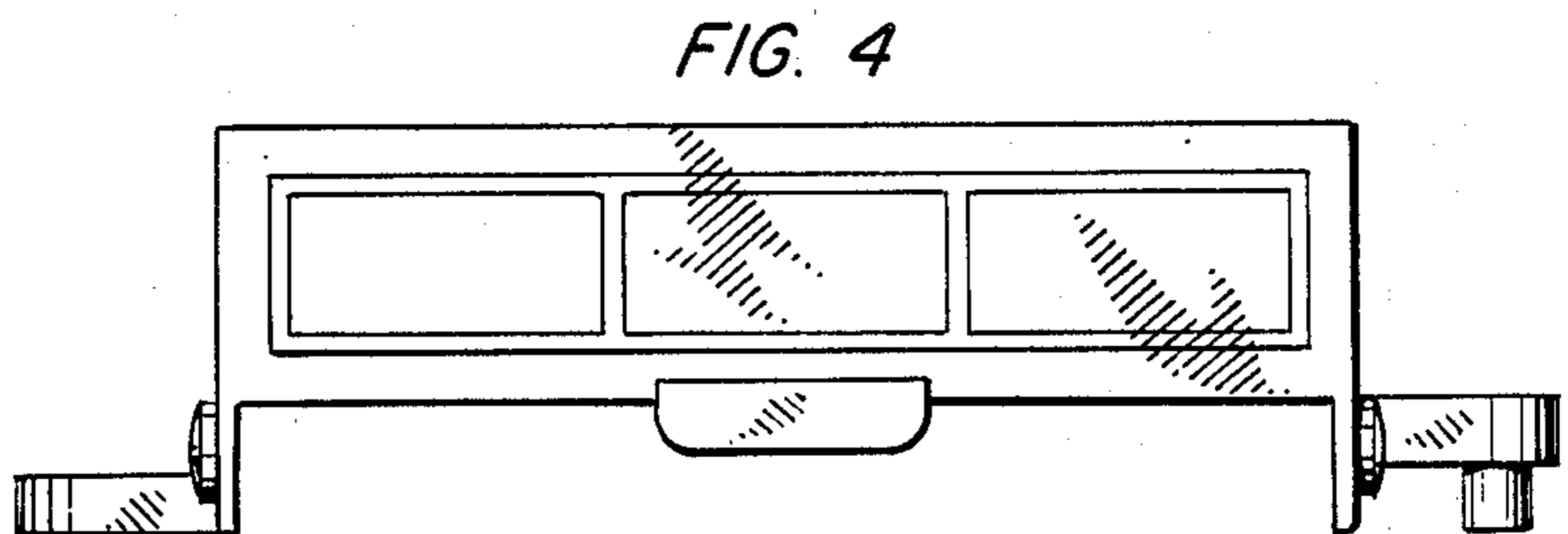

FIG. 4

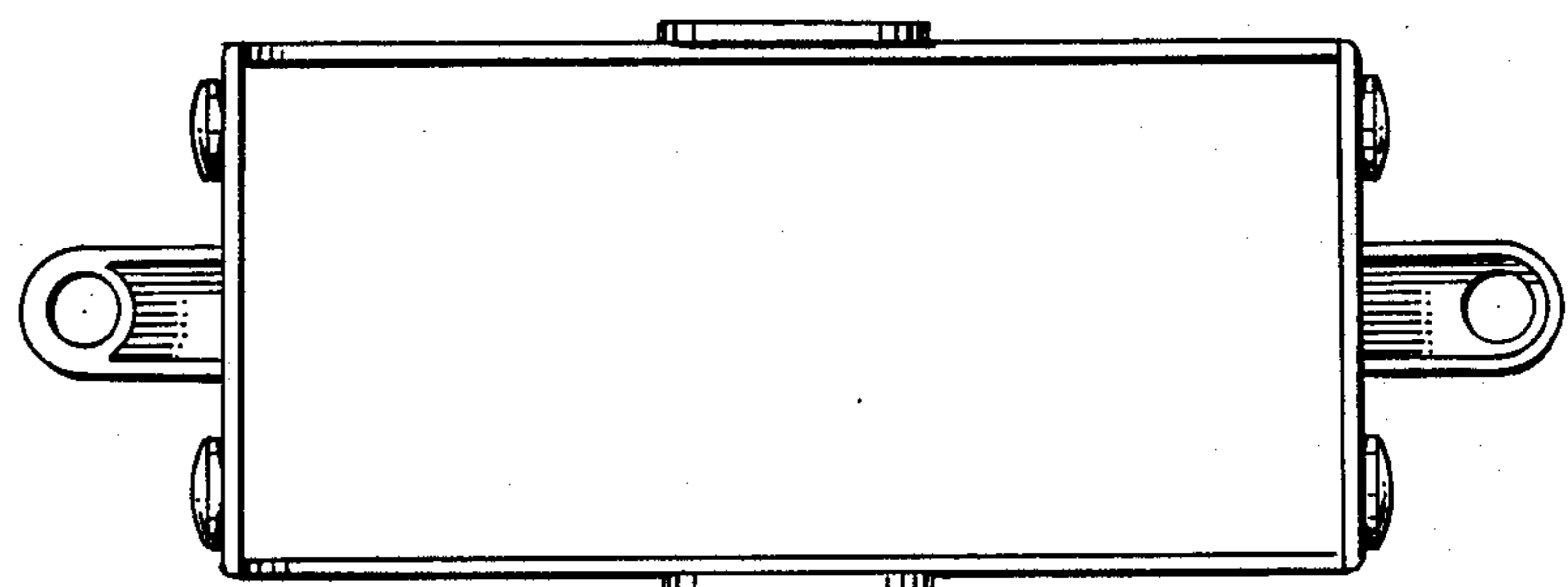

FIG. 3