

United States Patent [19]

Mulroy, Jr.

[11] Patent Number: **Des. 313,609**

[45] Date of Patent: **** Jan. 8, 1991**

[54] **GUITAR HEAD**

[75] Inventor: **Andrew F. Mulroy, Jr., Jamaica Estates, N.Y.**

[73] Assignee: **48th St. Custom Guitars, New York, N.Y.**

[**] Term: **14 Years**

[21] Appl. No.: **122,005**

[22] Filed: **Nov. 18, 1987**

[52] U.S. Cl. **D17/20**

[58] Field of Search **D17/14, 20; 84/267, 84/291, 293, 304**

[56] **References Cited**

U.S. PATENT DOCUMENTS

D. 207,426	4/1967	Ludwick	D17/20
D. 258,739	3/1981	Todd, III	D17/14
D. 268,685	4/1983	Seshimoto	D17/20
D. 274,732	7/1984	Hampton et al.	D17/14

D. 277,765	2/1985	Sugai	D17/20
4,408,515	10/1985	Sciuto	84/267

OTHER PUBLICATIONS

T.M. Reg. 1,416,289—Registered Nov. 4, 1986.

Primary Examiner—Bernard Ansher
Assistant Examiner—Adir Aronovich
Attorney, Agent, or Firm—Davis Hoxie Faithfull & Hapgood

[57] **CLAIM**

The ornamental design for a guitar head, as shown.

DESCRIPTION

FIG. 1 is a top front perspective view of a guitar head showing my new design;
FIG. 2 is a top plan view thereof;
FIG. 3 is a front elevational view thereof;
FIG. 4 is a cross section taken on line 4—4 of FIG. 6;
FIG. 5 is a right end elevational view;
FIG. 6 is a rear elevational view; and
FIG. 7 is a bottom plan view.

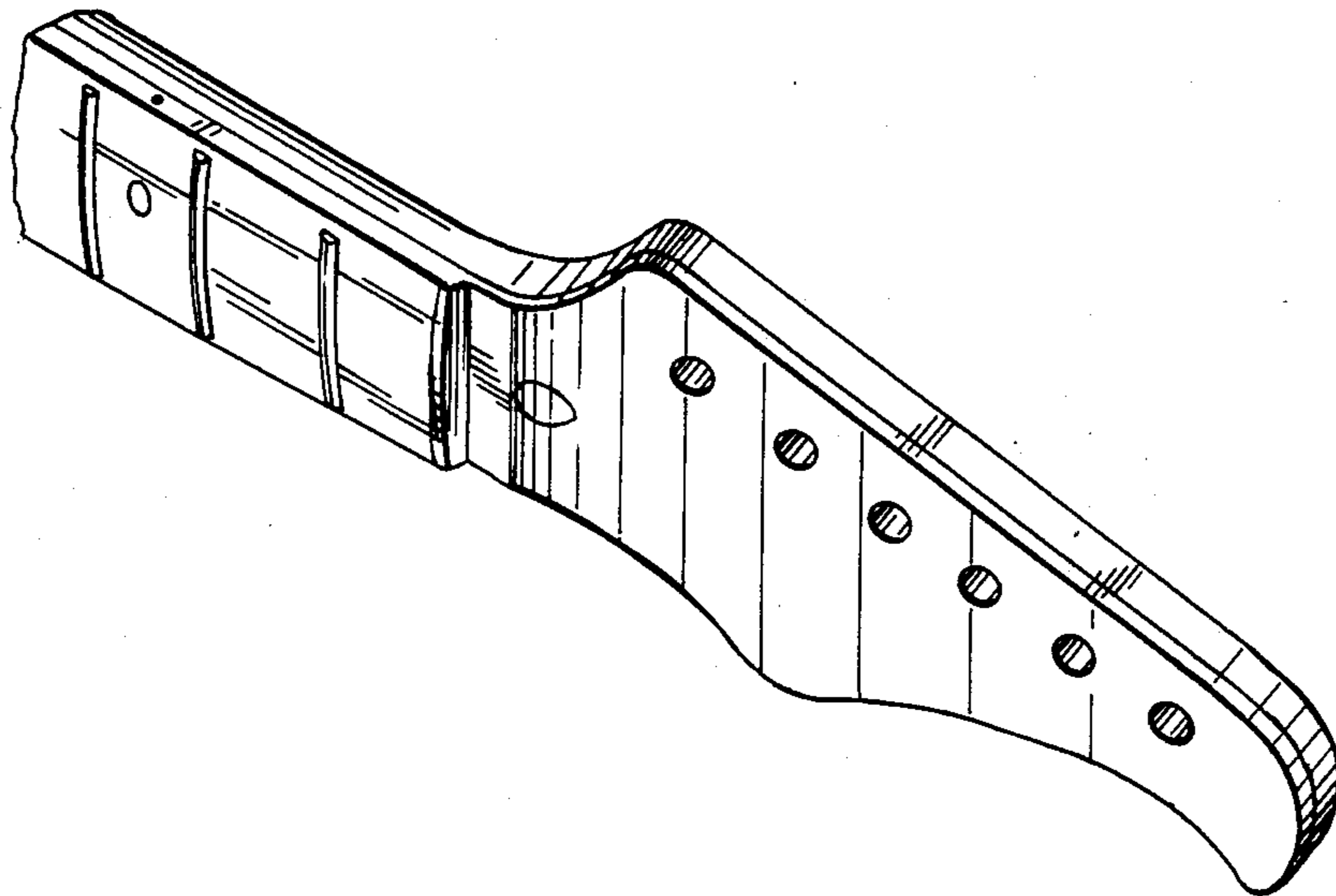

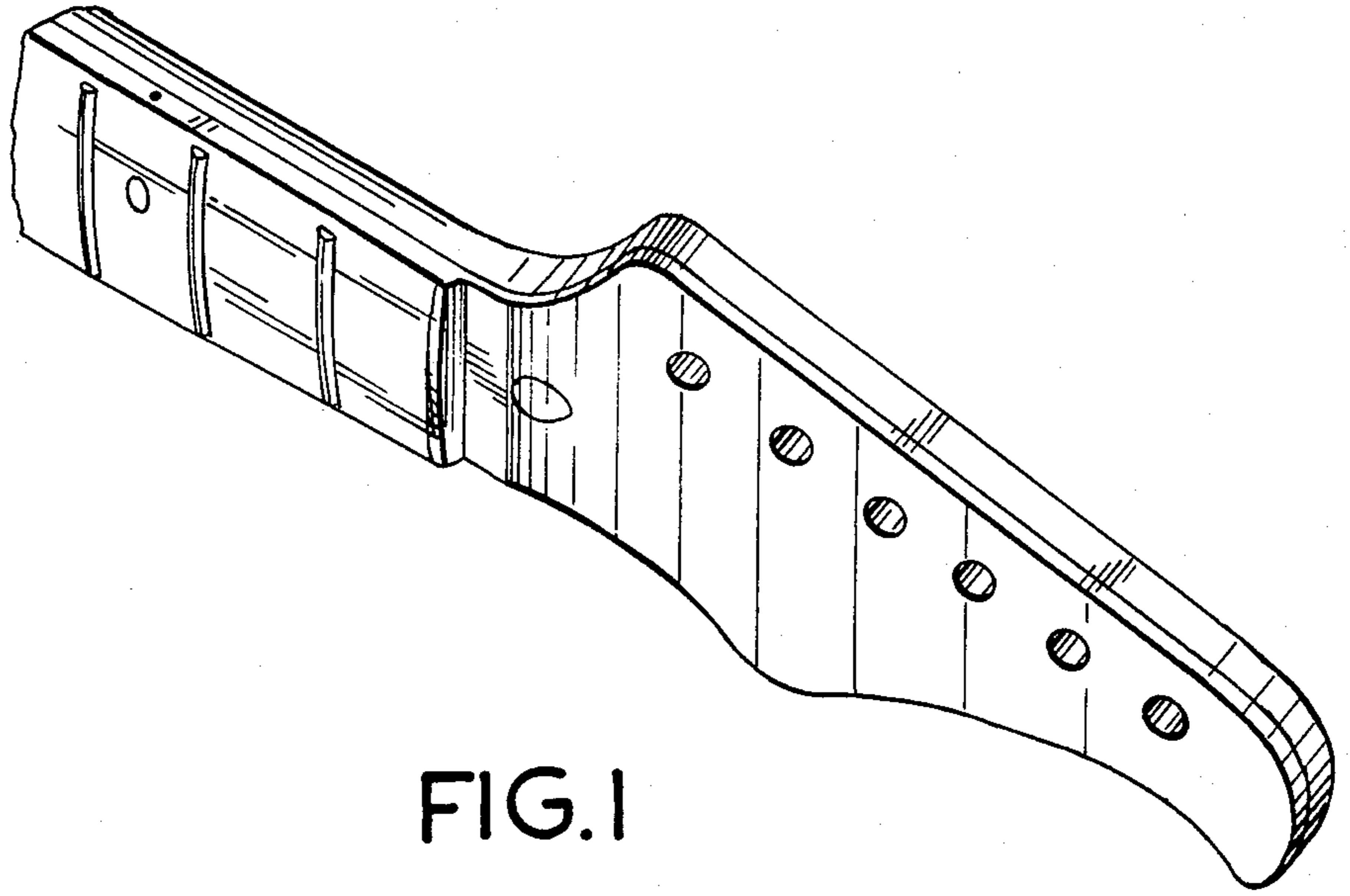

FIG. 1

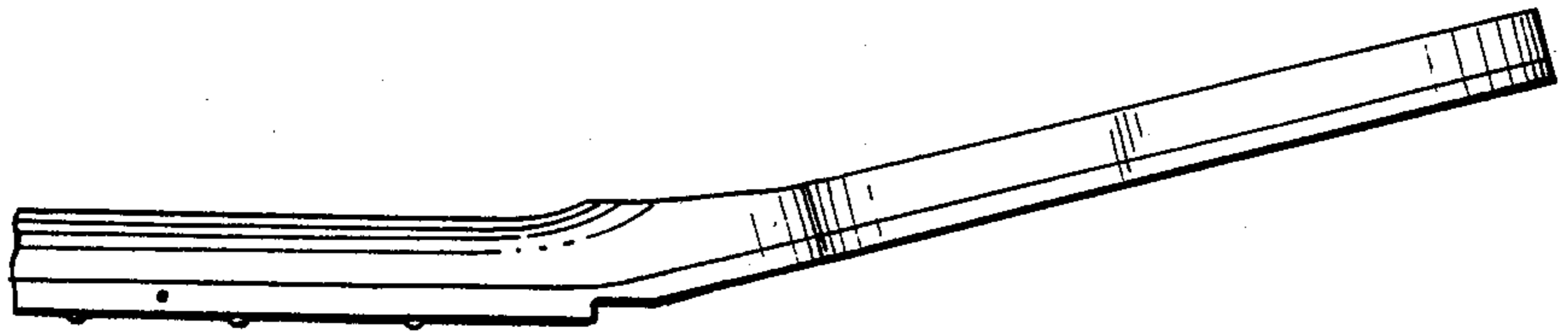

FIG. 2

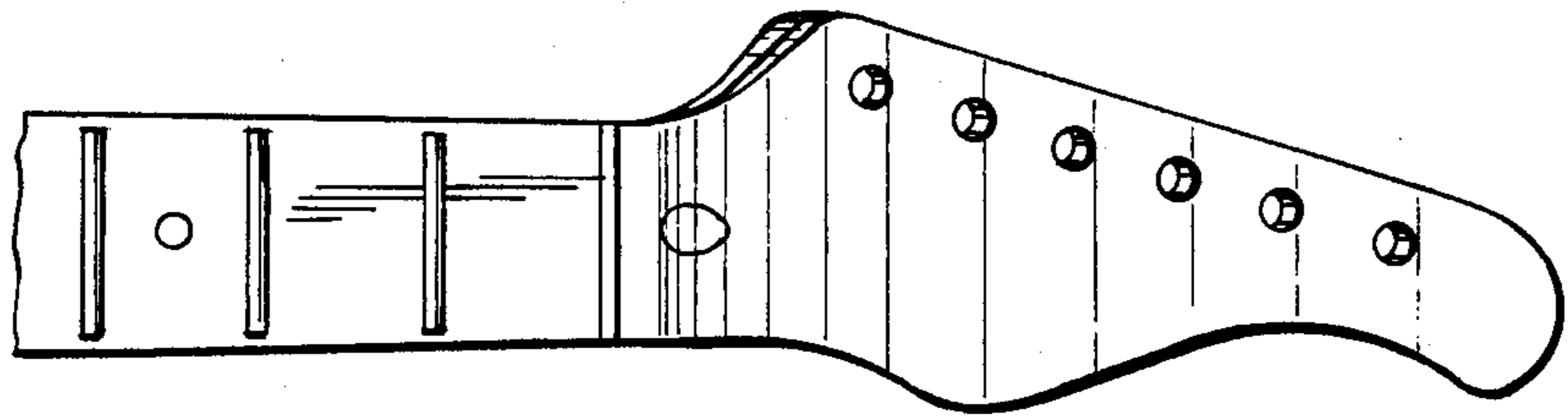

FIG. 3

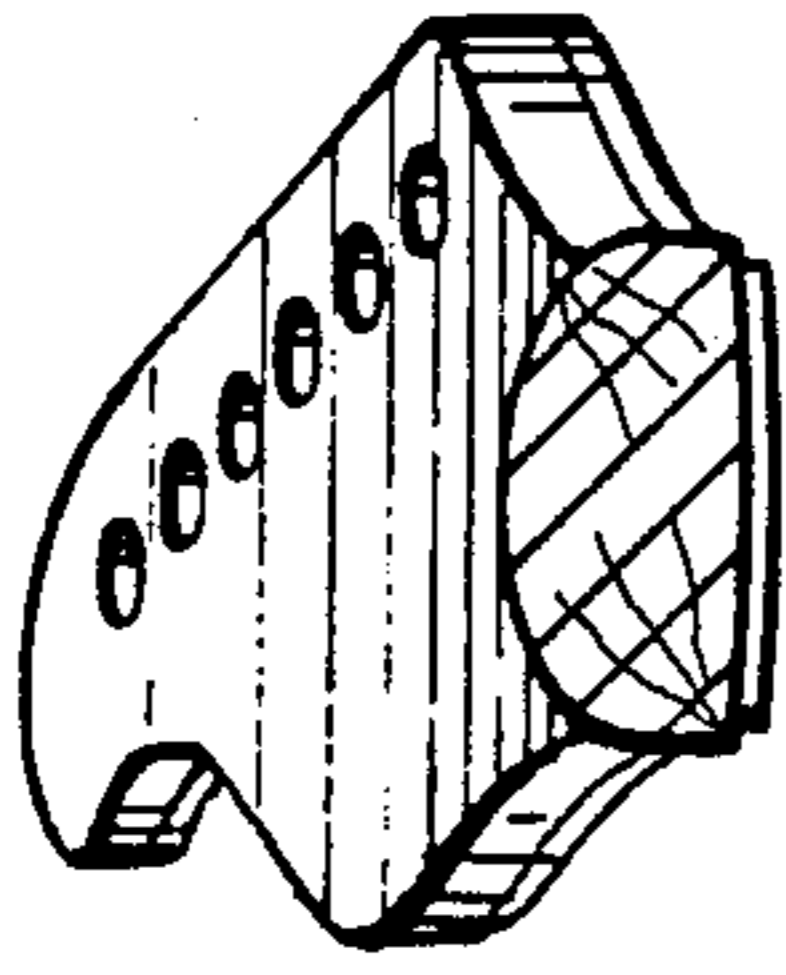

FIG. 4

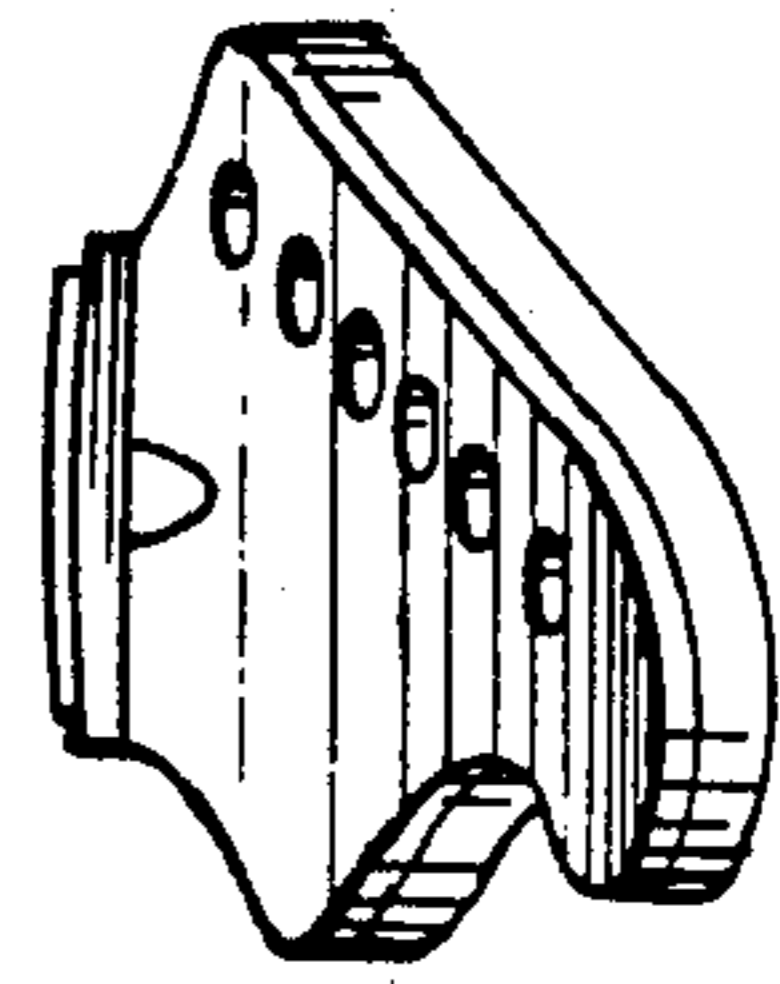

FIG. 5

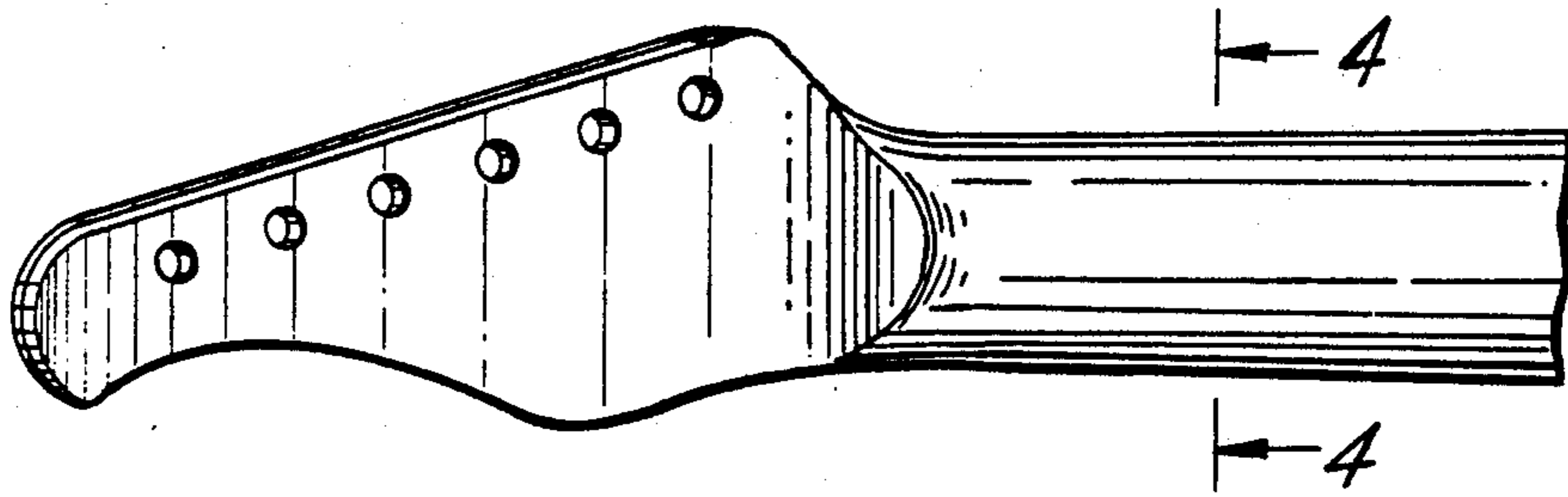

FIG. 6

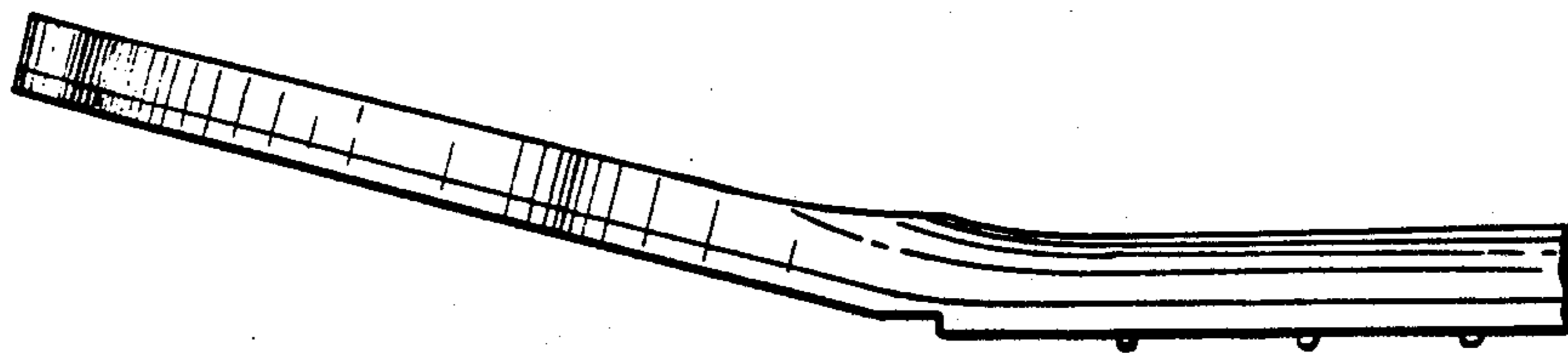

FIG. 7