

[54] **FORK LIFT**

[75] **Inventor: Richard Soederberg, Muehlacker, Fed. Rep. of Germany**

[73] **Assignee: Dr. Ing. h.c.F. Porsche AG, Fed. Rep. of Germany**

[\*\*] **Term: 14 Years**

[21] **Appl. No.: 163,399**

[22] **Filed: Feb. 26, 1988**

[30] **Foreign Application Priority Data**

Aug. 26, 1987 [DE] Fed. Rep. of Germany ..... MR 6300

[52] **U.S. Cl. .... D34/28; D12/14; D34/37**

[58] **Field of Search ..... D34/34, 28; D12/14, D12/15; 187/9 R, 9 E; 180/253**

[56] **References Cited**

**U.S. PATENT DOCUMENTS**

D. 139,759 12/1944 Johnson ..... D34/34  
D. 222,694 12/1971 Goodacre ..... D34/34

D. 244,439 5/1977 Carr et al. .... D34/34  
2,925,887 2/1960 Gibson ..... D34/34

**OTHER PUBLICATIONS**

Komatsu Forklift Co. brochure, cover page, FB 15M Forklift.

*Primary Examiner*—Kay H. Chin  
*Attorney, Agent, or Firm*—Evenson, Wands, Edwards, Lenahan & McKeown

[57] **CLAIM**

The ornamental design for a fork lift, as shown and described.

**DESCRIPTION**

FIG. 1 is a left side elevational view of a fork lift showing my new design;  
FIG. 2 is a front perspective view thereof;  
FIG. 3 is a right side elevational view thereof;  
FIG. 4 is a rear perspective view thereof;  
FIG. 5 is a front elevational view thereof;  
FIG. 6 is a rear elevational view thereof; and  
FIG. 7 is a top plan view thereof.

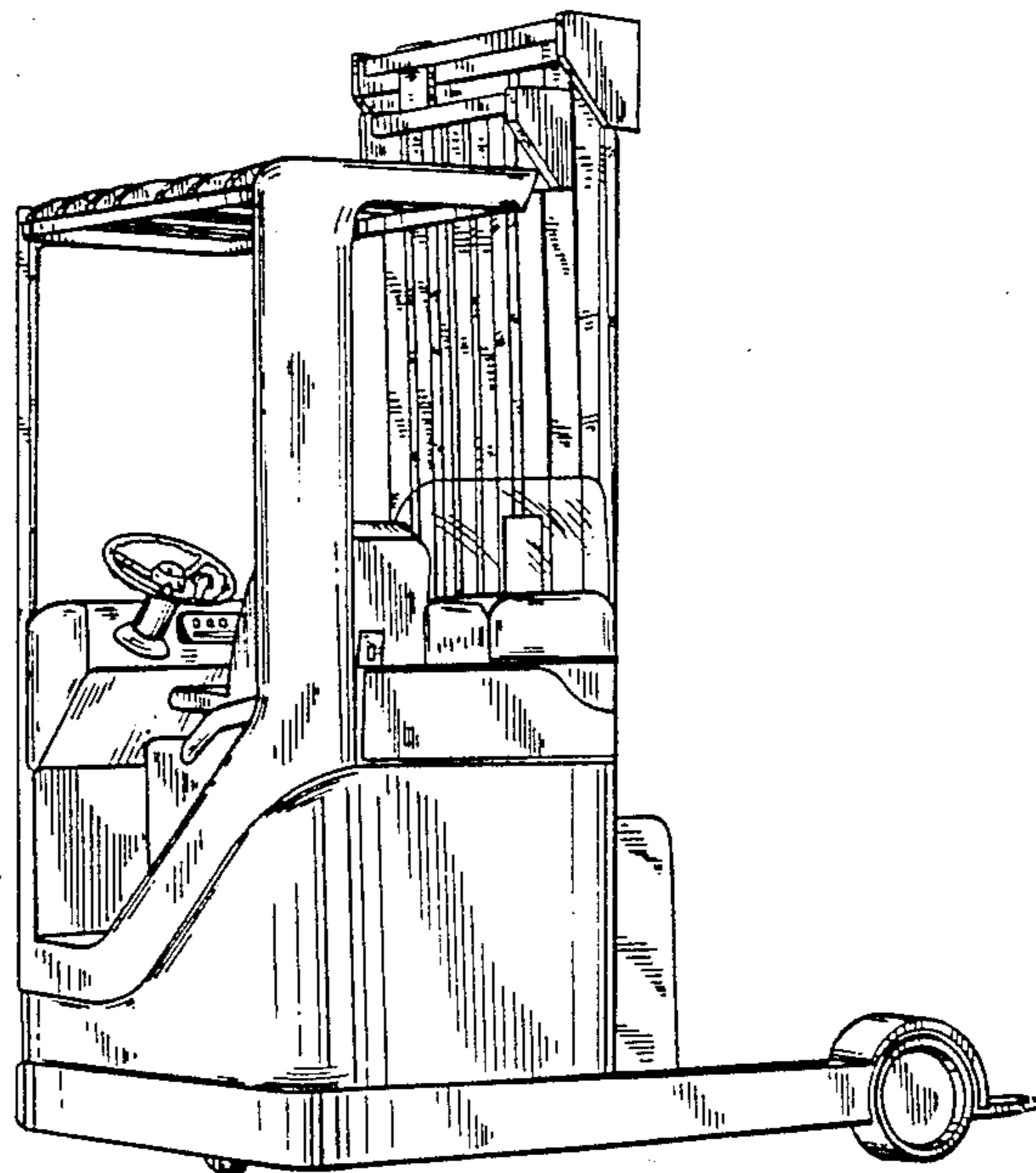

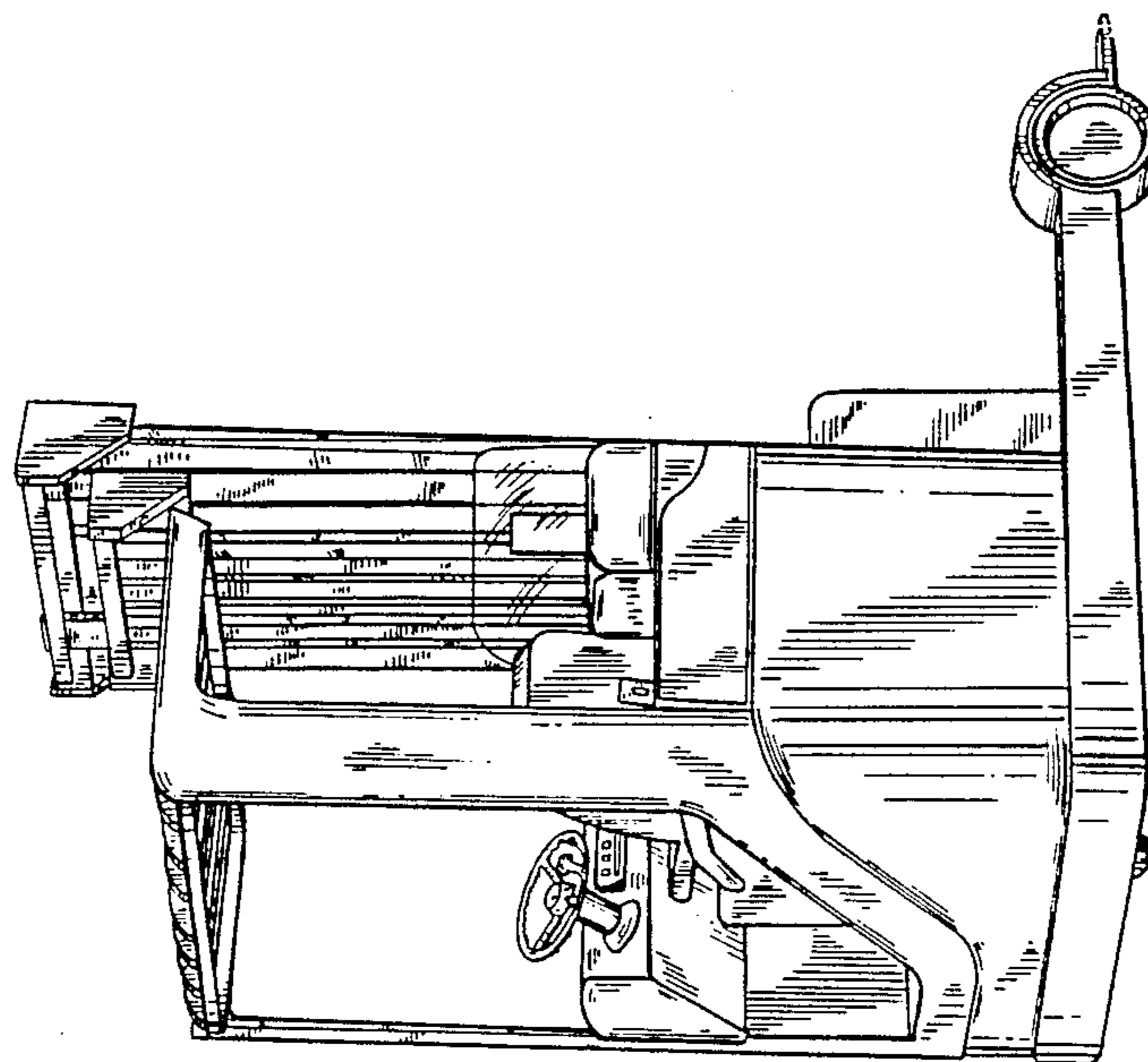

FIG. 2

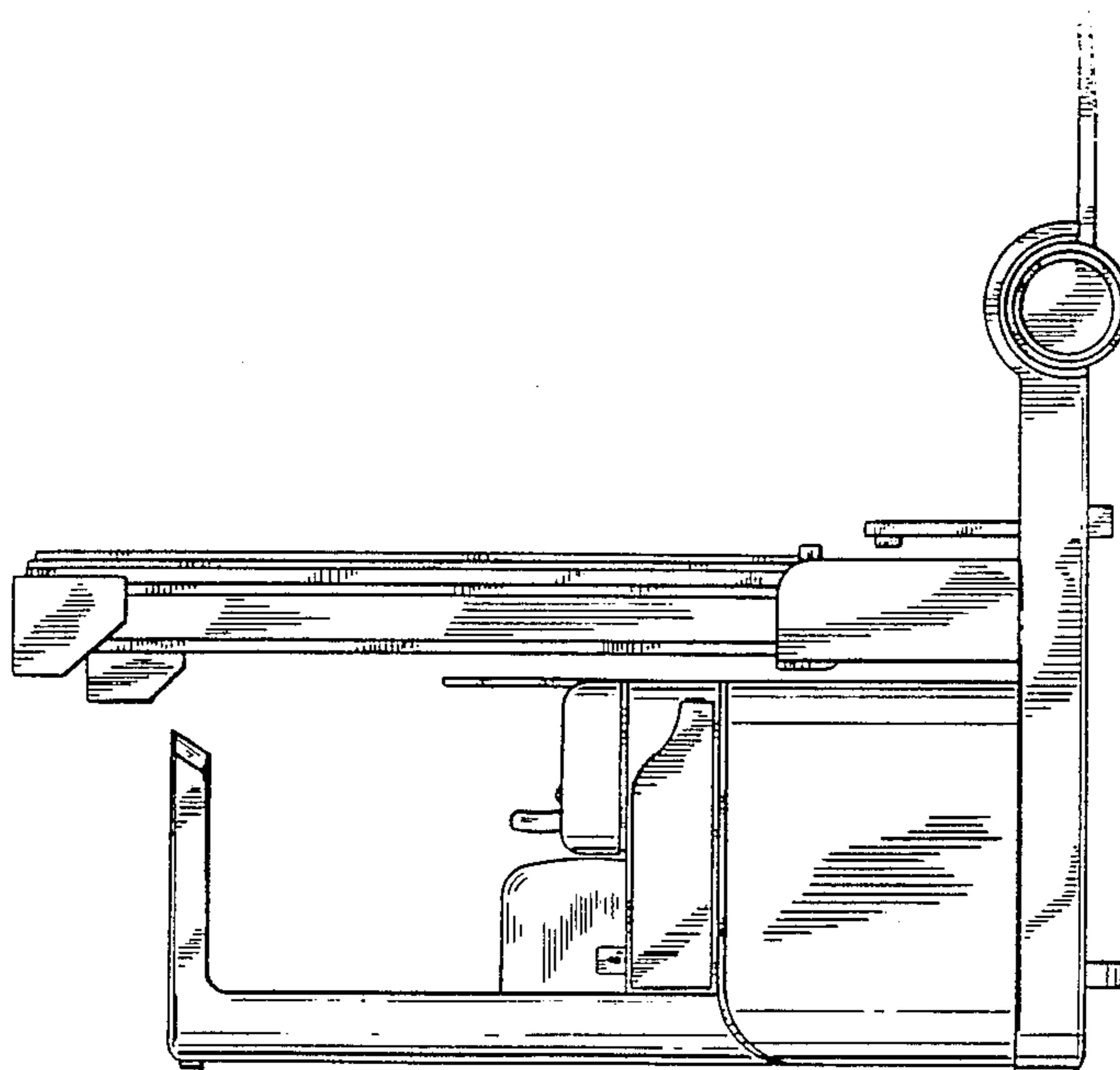

FIG. 1

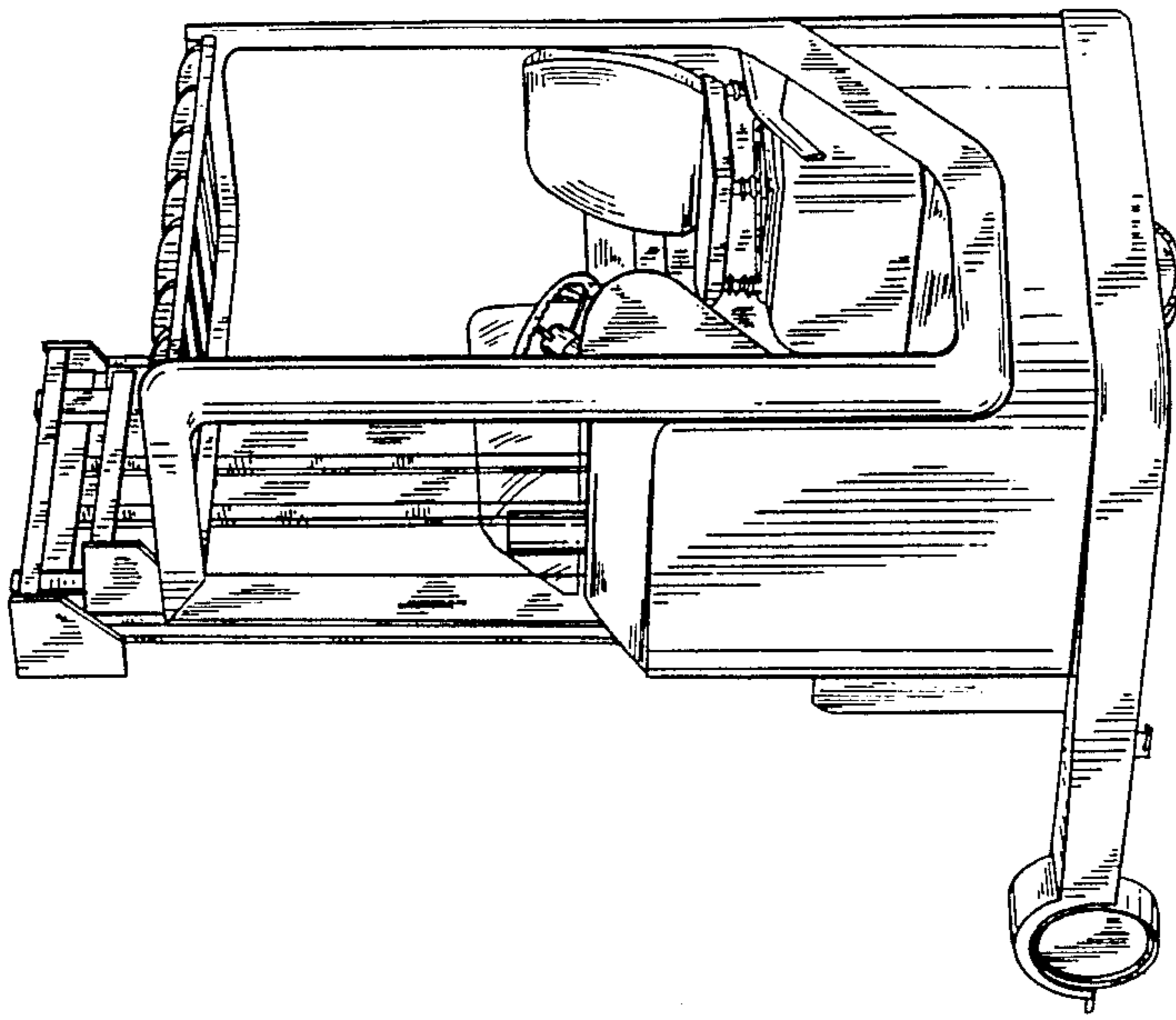

FIG. 4

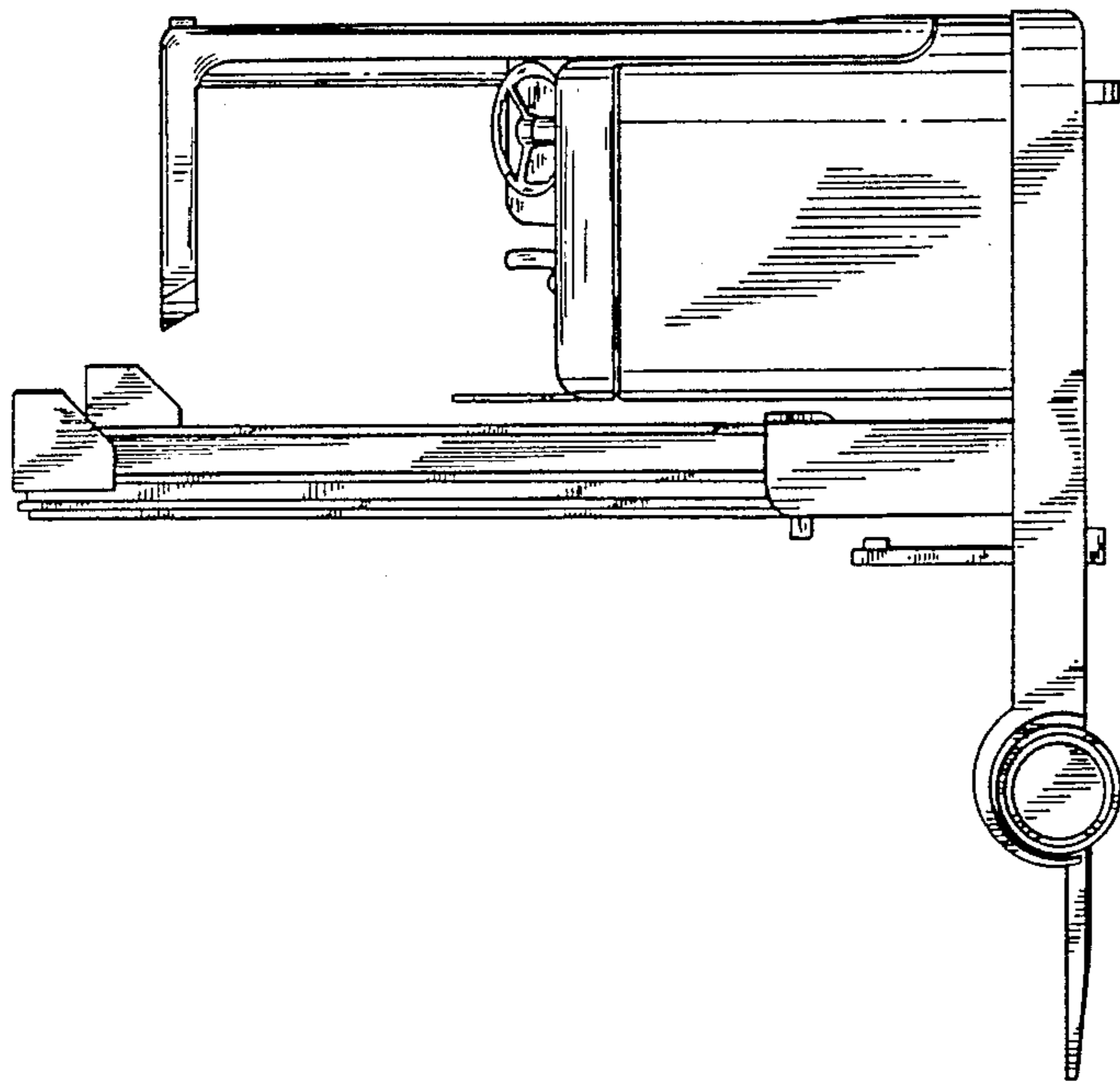

FIG. 3

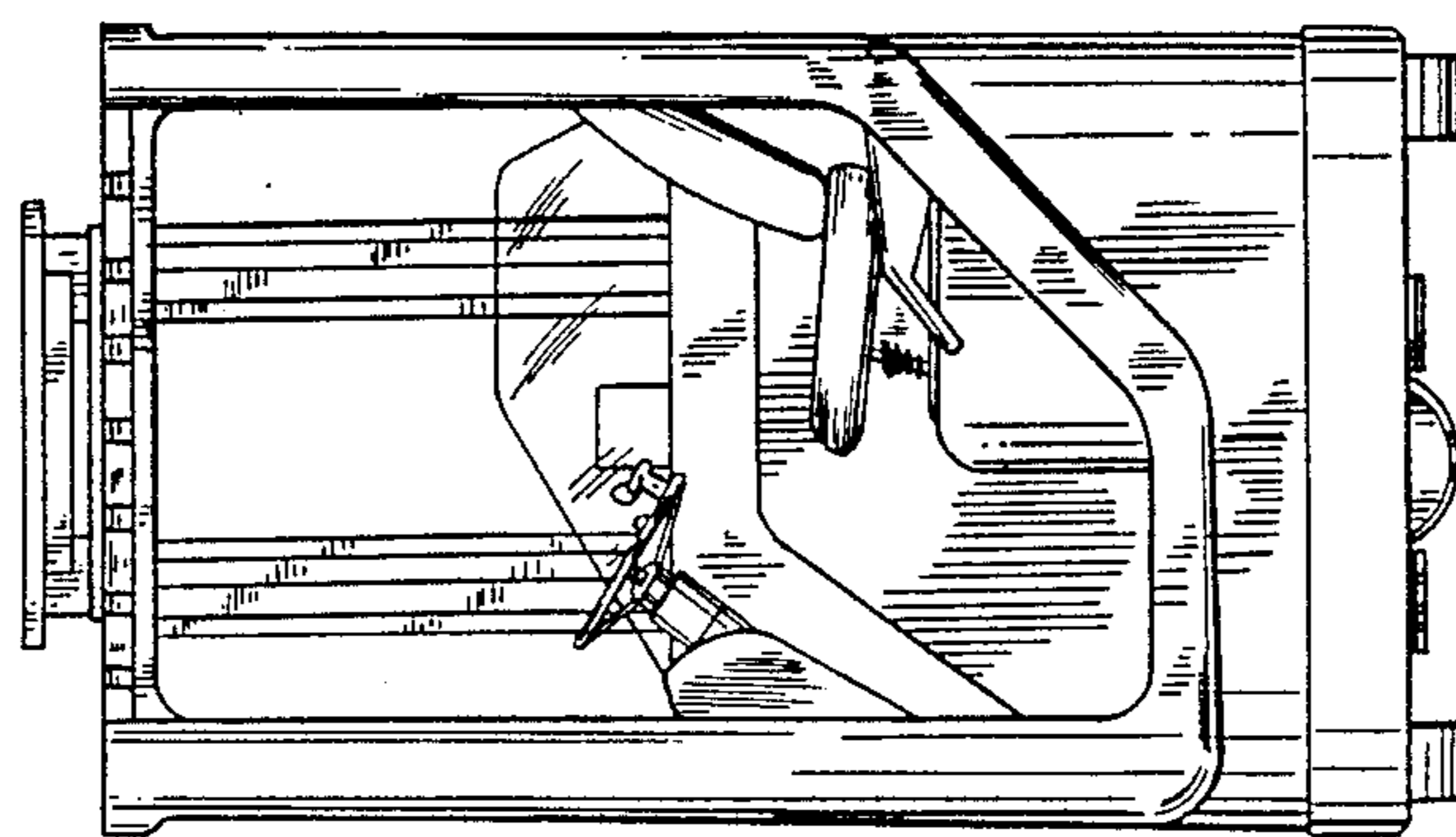

FIG. 6

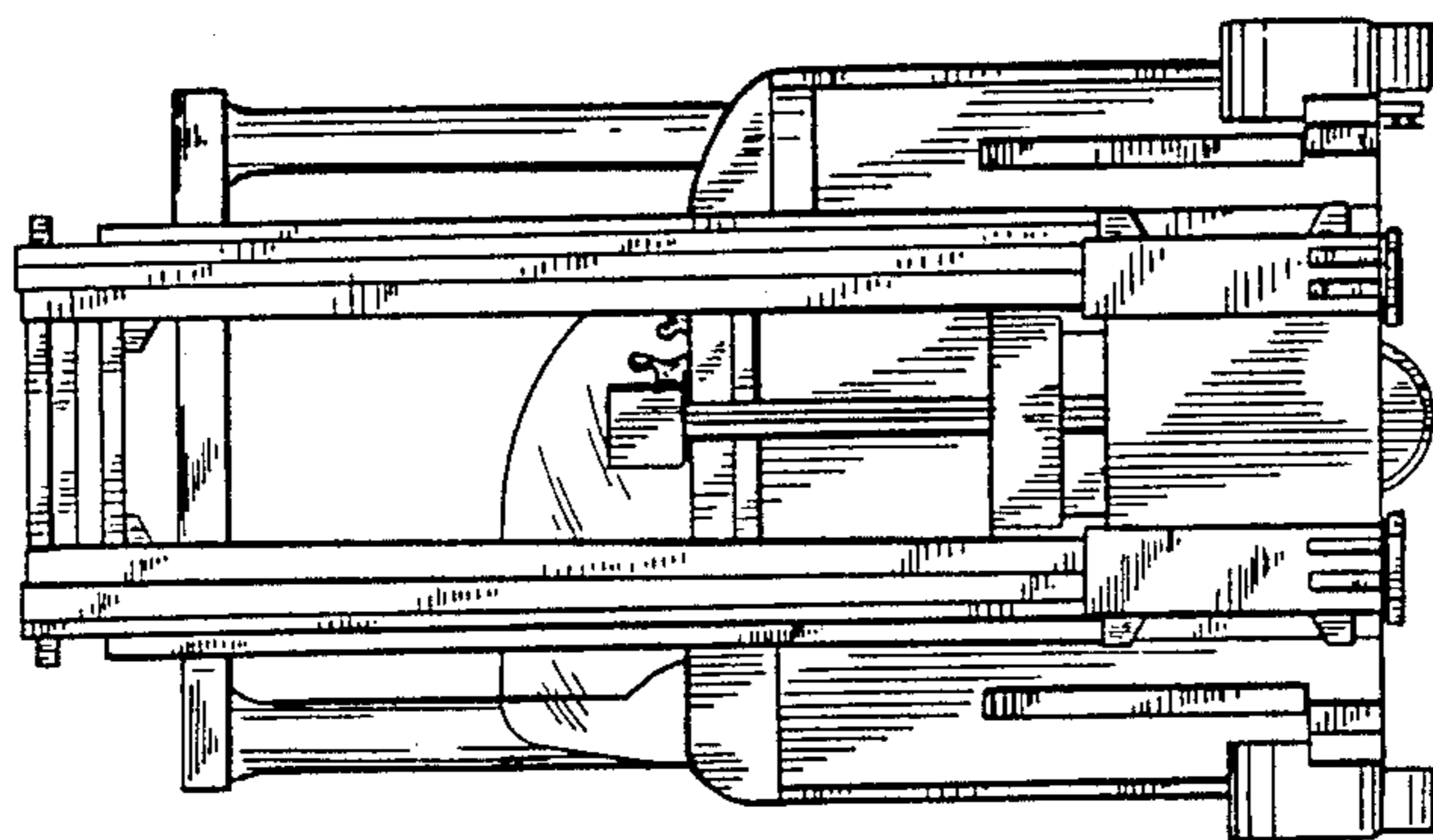
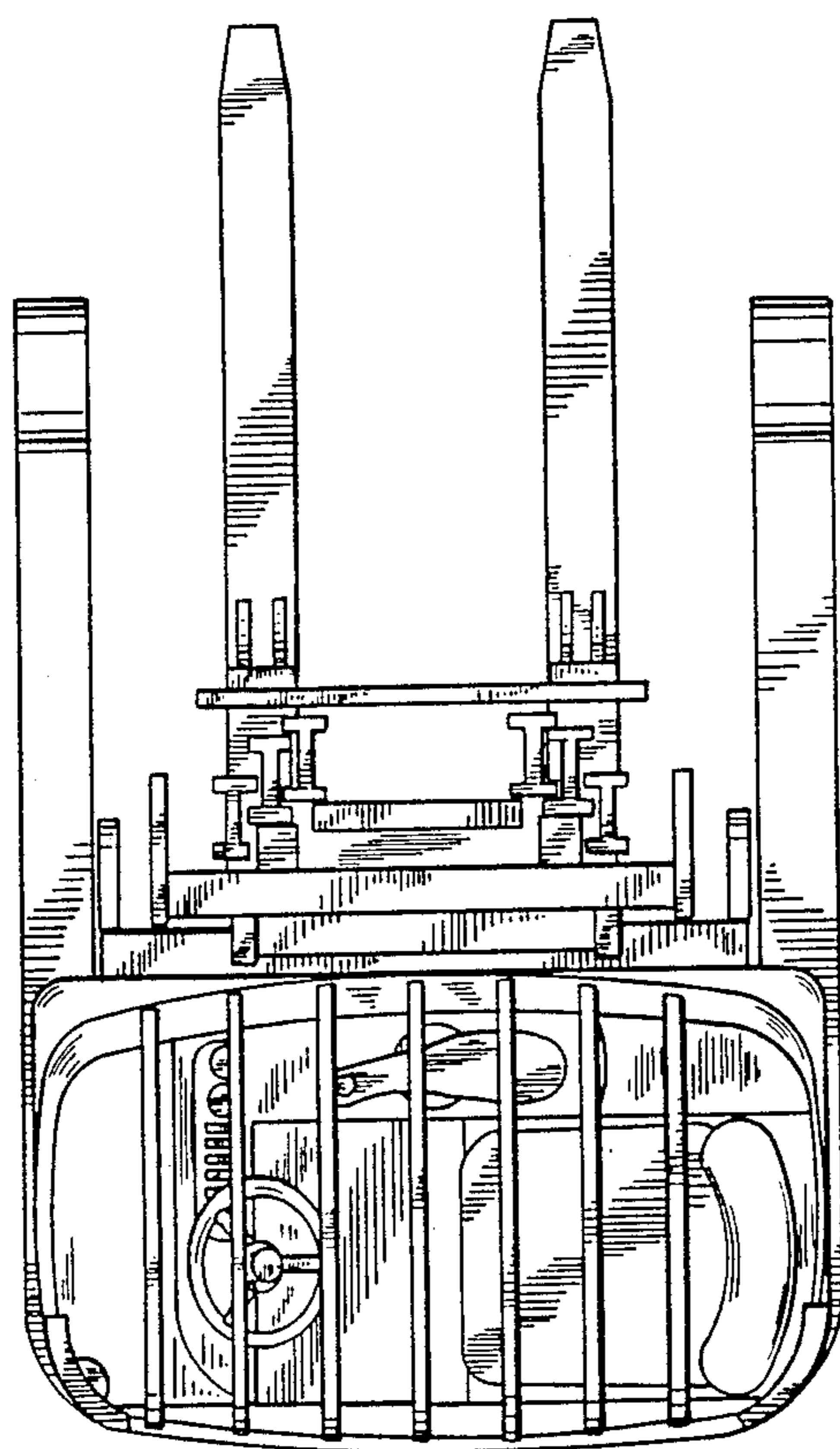

FIG. 5



*FIG. 7*