

United States Patent [19]
Kuli

[11] **Patent Number: Des. 312,987**
[45] **Date of Patent: ** Dec. 18, 1990**

[54] **TRACTOR SEAT BELT HOLDER SET**
[76] **Inventor: Amiel Kuli, 1449 Berlin Rd.,
Wilmington, Ohio 45177**
[**] **Term: 14 Years**
[21] **Appl. No.: 112,764**
[22] **Filed: Oct. 26, 1987**
[52] **U.S. Cl. D11/218; D5/373;
24/171**
[58] **Field of Search D8/356, 383, 373;
24/633, 639, 171, 194; 242/803; D24/198, 199,
200, 163, 156; D11/200, 231, 218, 213, 212**

4,498,689 2/1985 Duffield et al. 280/803
4,570,873 2/1986 Kurtti 280/803
4,608,735 9/1986 Kasai 24/194 X
4,624,033 11/1986 Orton 24/633
4,669,155 6/1987 Chen 24/171 X
4,675,954 6/1987 Gullickson 24/633
4,791,711 12/1988 Adams 24/633
4,802,262 2/1989 Kasai 24/633 X
4,878,271 11/1989 Kitokovsky 24/194
4,903,377 2/1990 Doty 24/171 X
4,903,378 2/1990 Kasai 24/171 X

[56] **References Cited**
U.S. PATENT DOCUMENTS
D. 164,750 10/1951 White D11/218
D. 270,615 9/1983 Stuart D8/381
1,055,008 3/1913 Wright D11/218 X
1,947,394 2/1934 Heinze 24/194 X
2,897,559 8/1959 Erdmann 24/194 X
3,267,542 8/1966 Sussman 24/194
3,537,148 11/1970 Carlmarlo 24/194 X
3,774,268 11/1973 Holmberg 24/639
4,168,850 9/1979 Stephenson et al. 280/803
4,201,401 5/1980 Bryan 280/803
4,284,295 8/1981 Takeda et al. 280/803

Primary Examiner—Horace B. Fay, Jr.
Attorney, Agent, or Firm—Jerry T. Kearns

[57] **CLAIM**

The ornamental design for a tractor seat belt holder set, as shown and described.

DESCRIPTION

FIG. 1 is a front elevational view of a bracket associated view of bolt components of a tractor seat belt holder set showing my new design;
FIG. 2 is a bracketed rear elevational view thereof;
FIG. 3 is a bracketed left side elevational view thereof;
FIG. 4 is a bracketed right side elevational view thereof;
FIG. 5 is a bracketed top plan view thereof; and
FIG. 6 is a bracketed bottom plan view thereof.

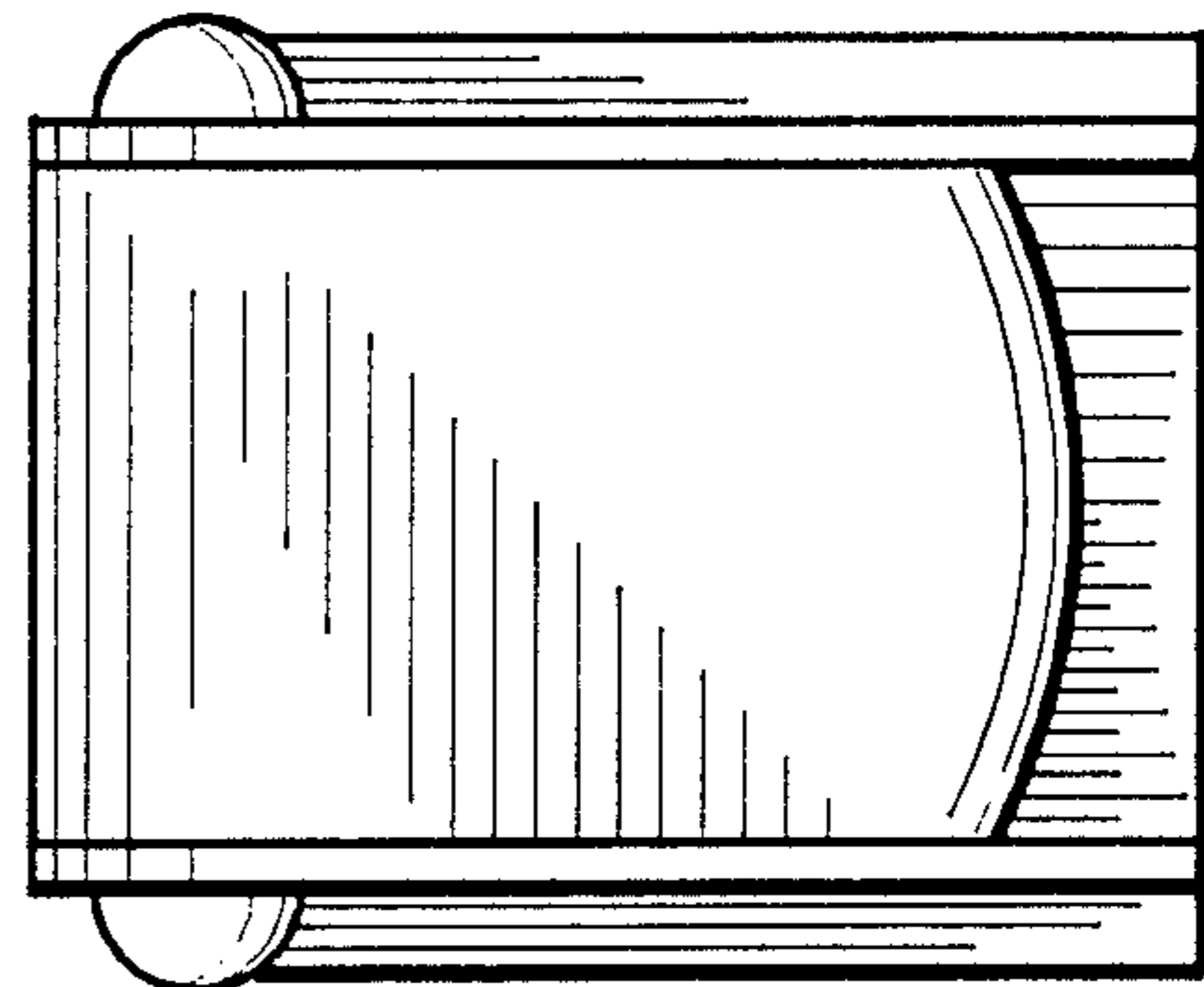
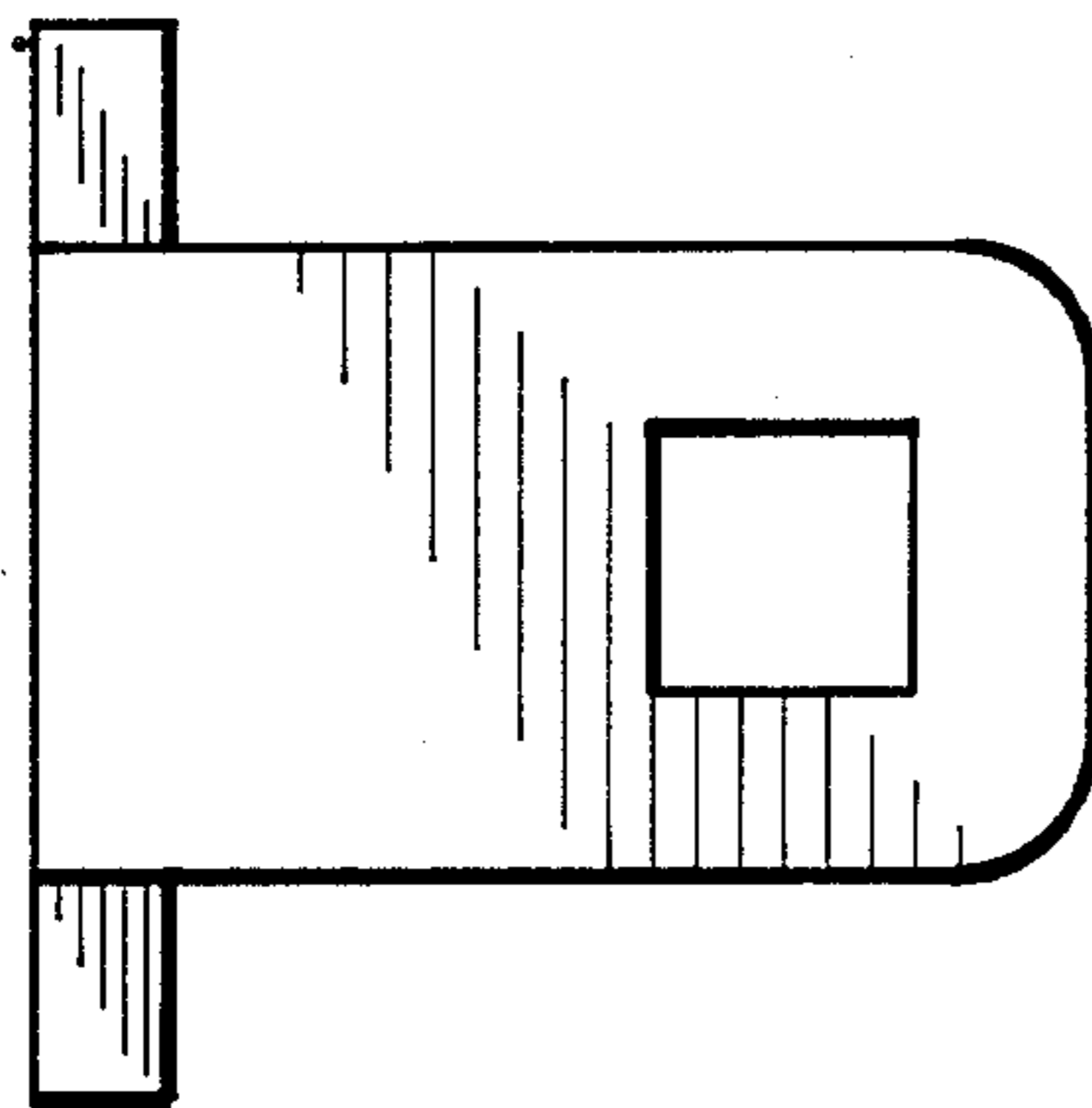

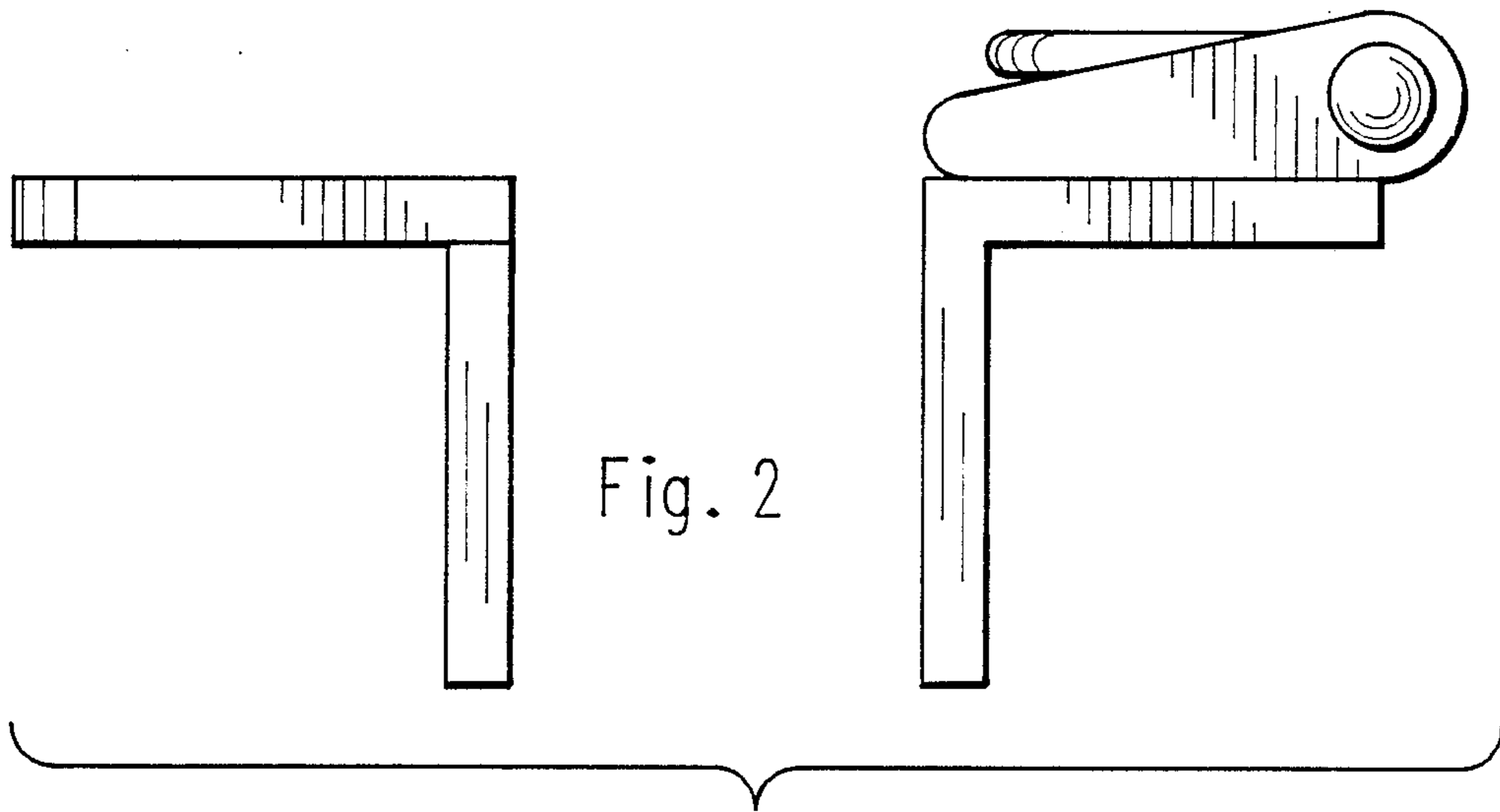
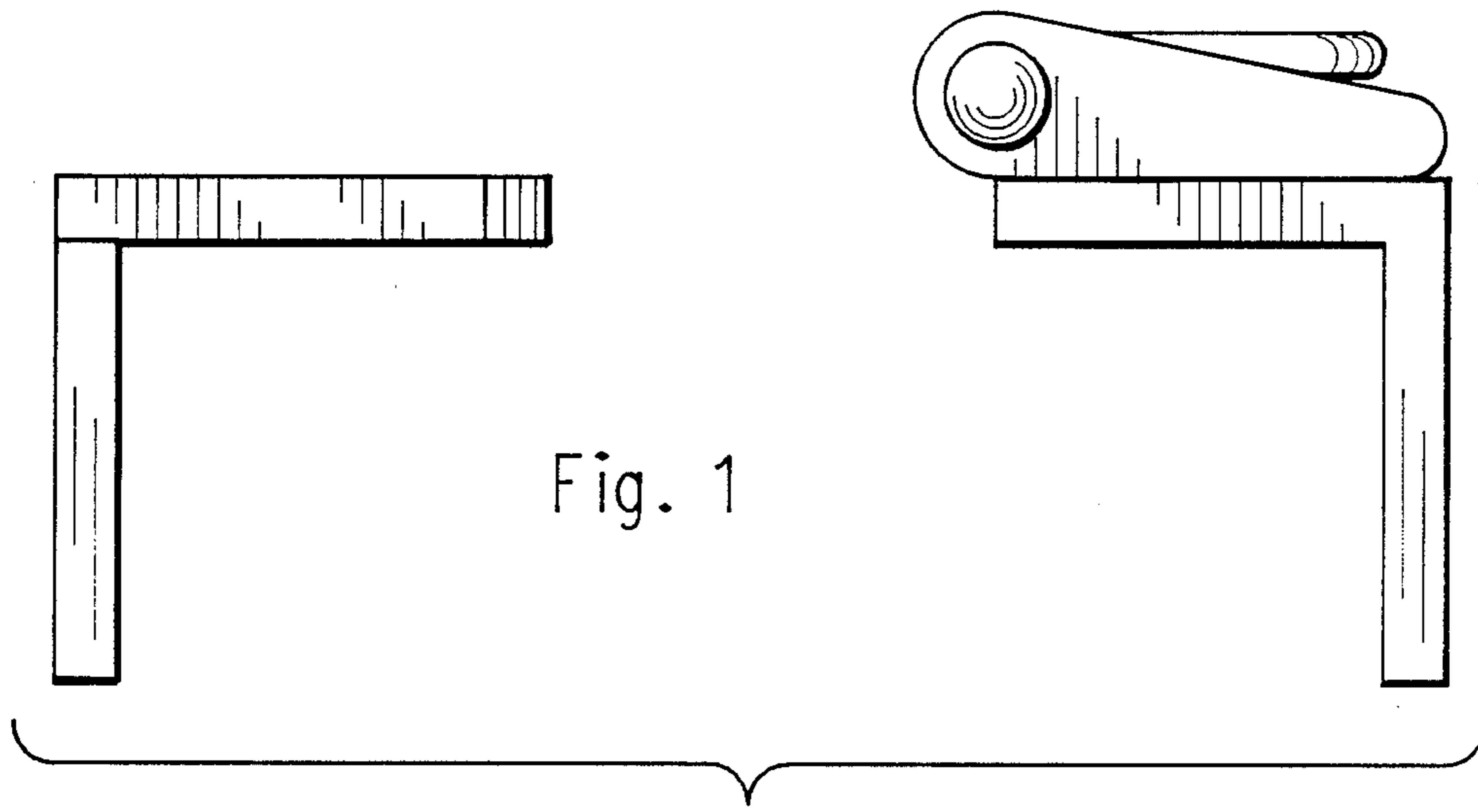

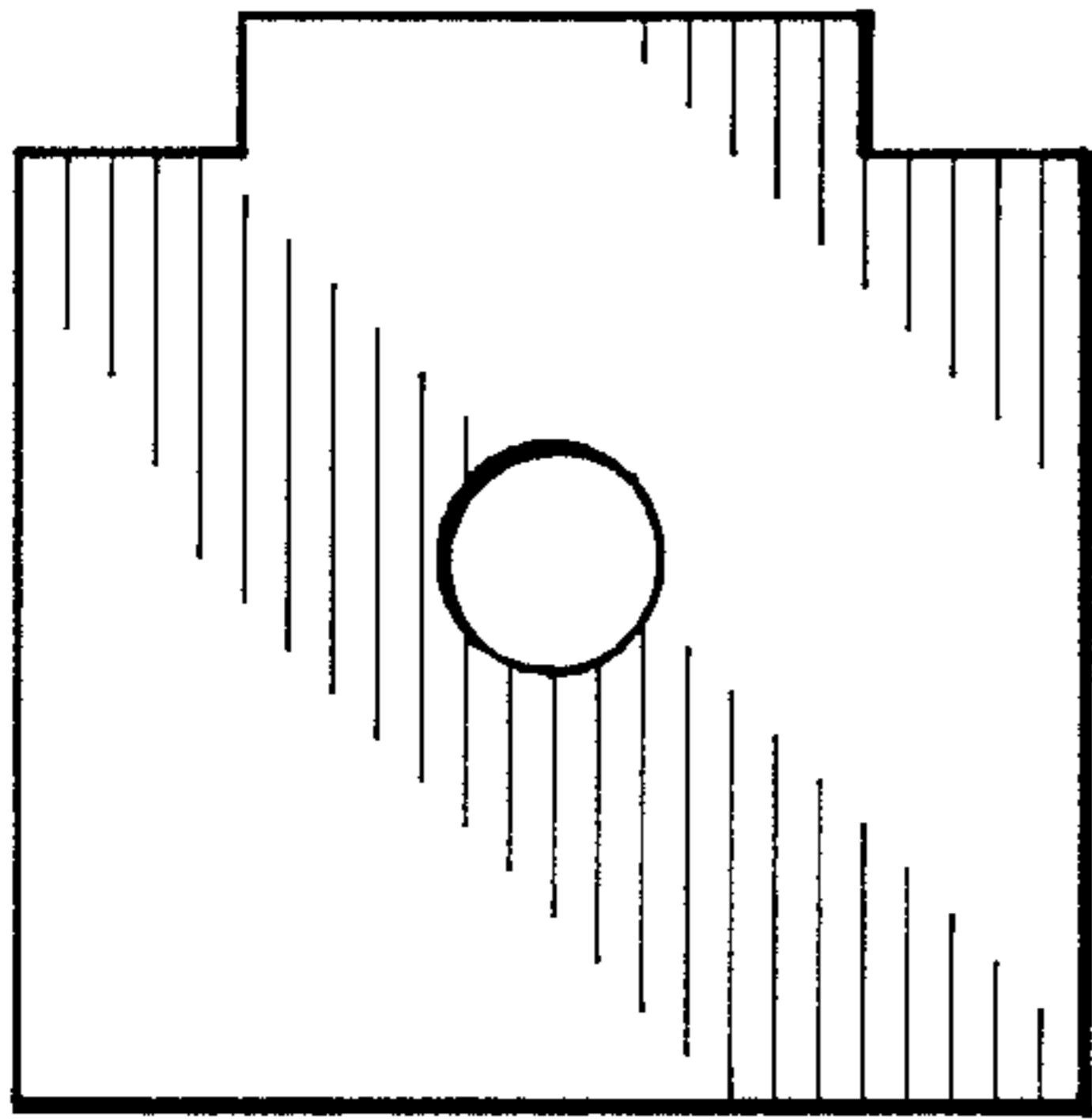

Fig. 3

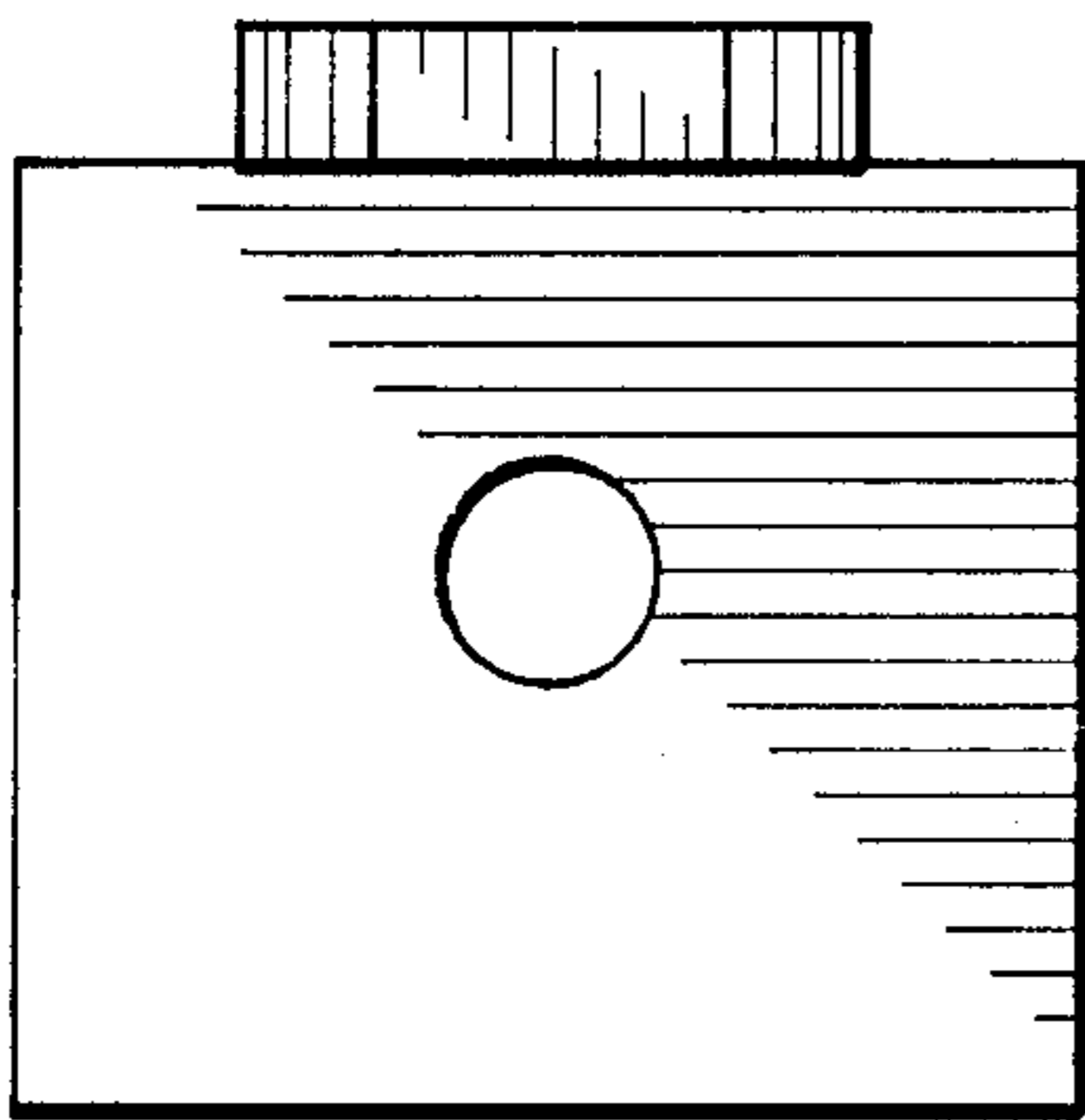
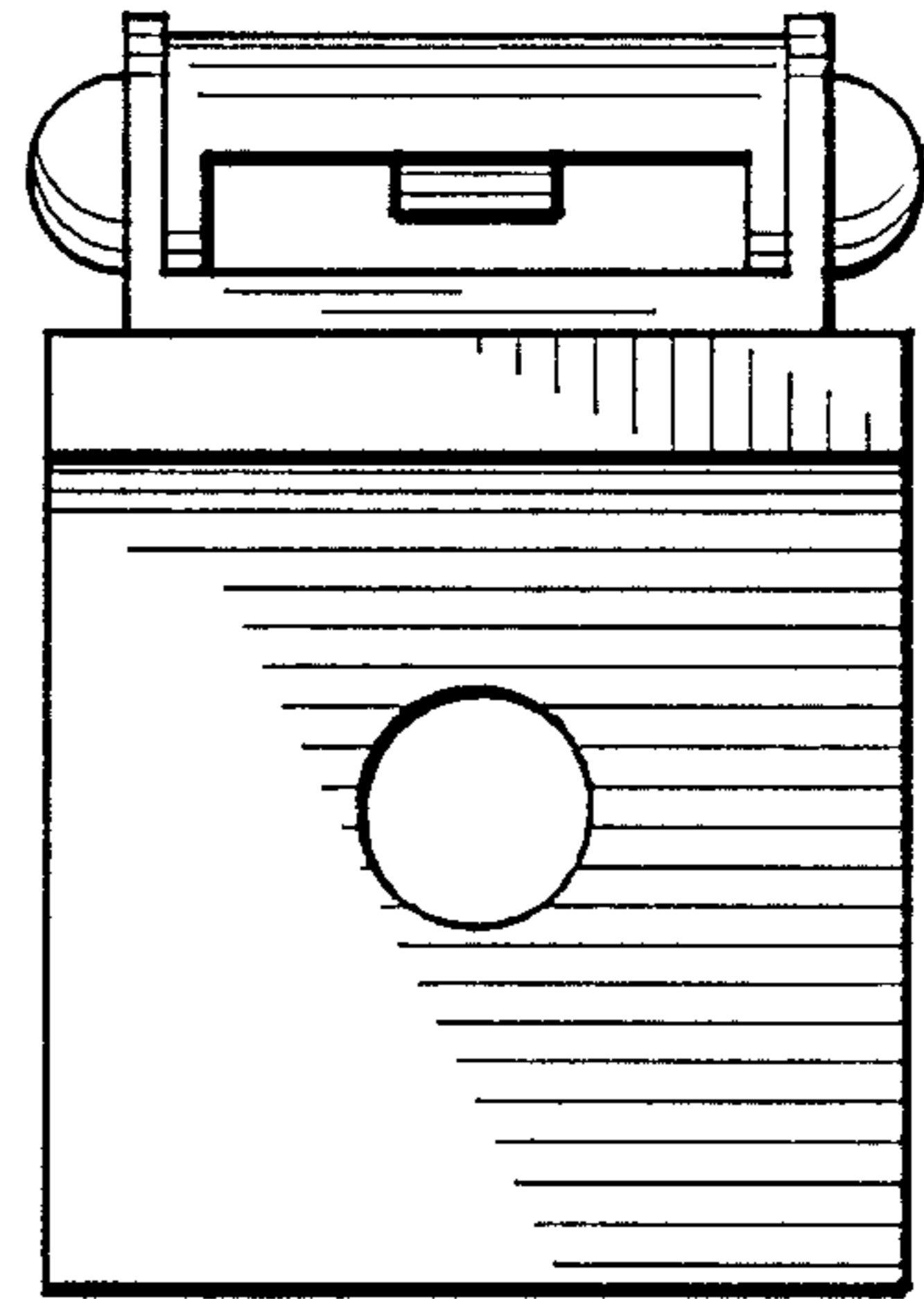
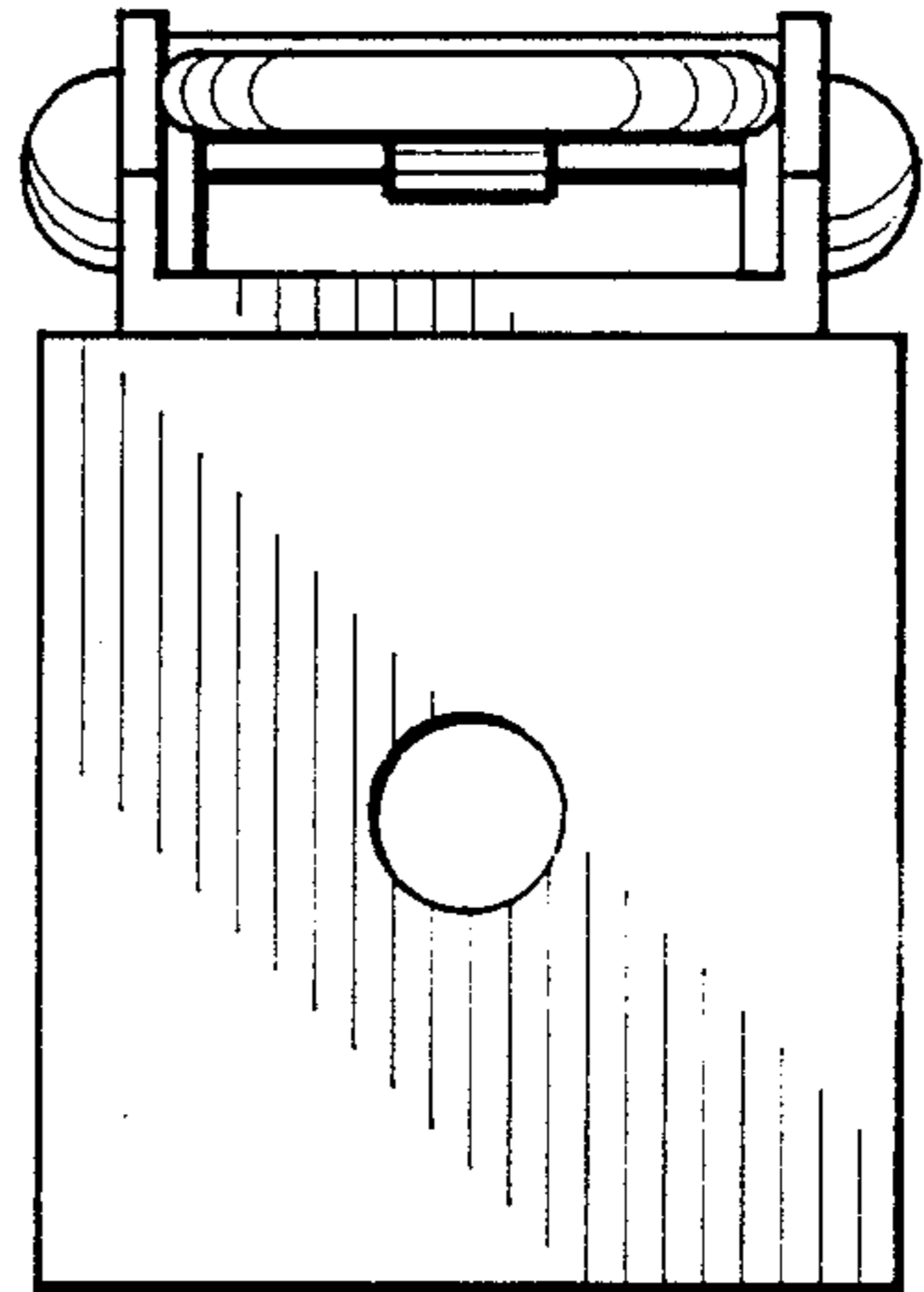

Fig. 4



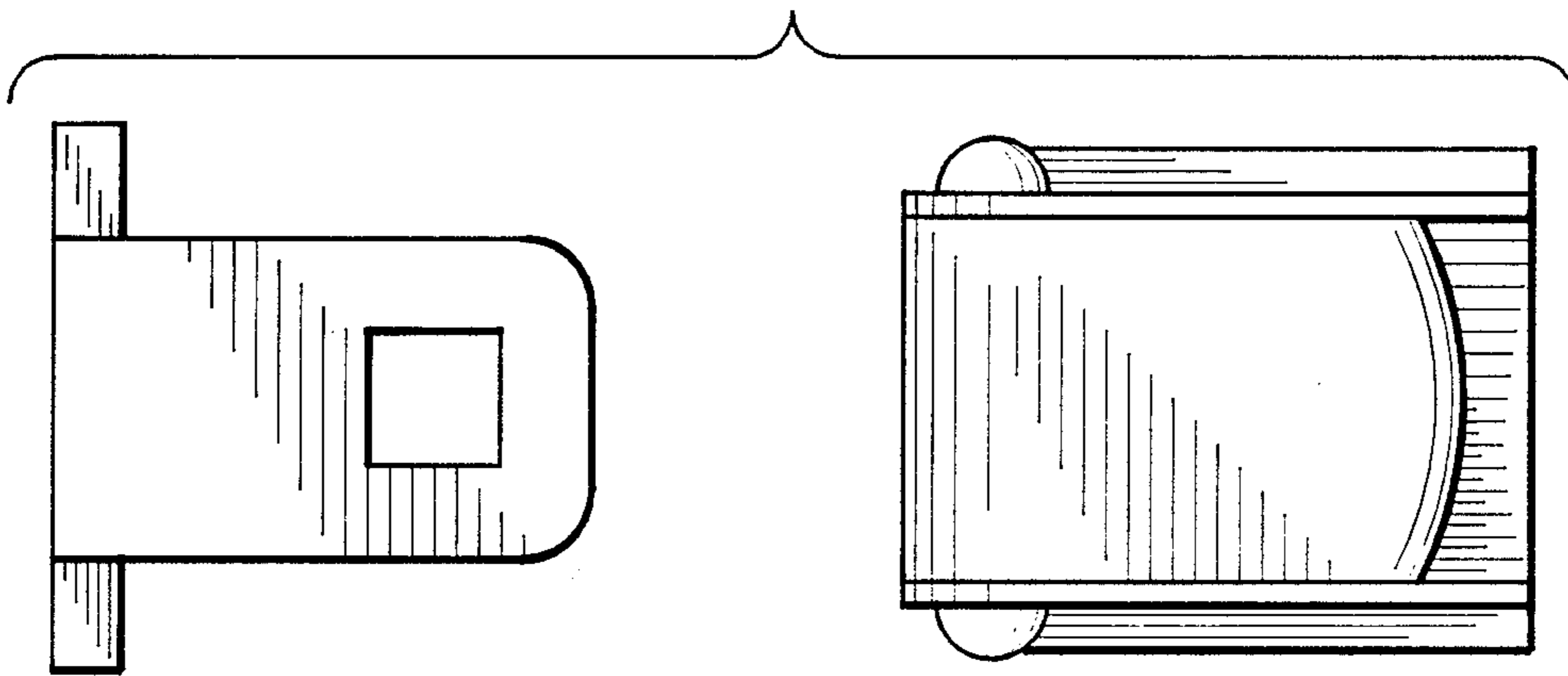

Fig. 5

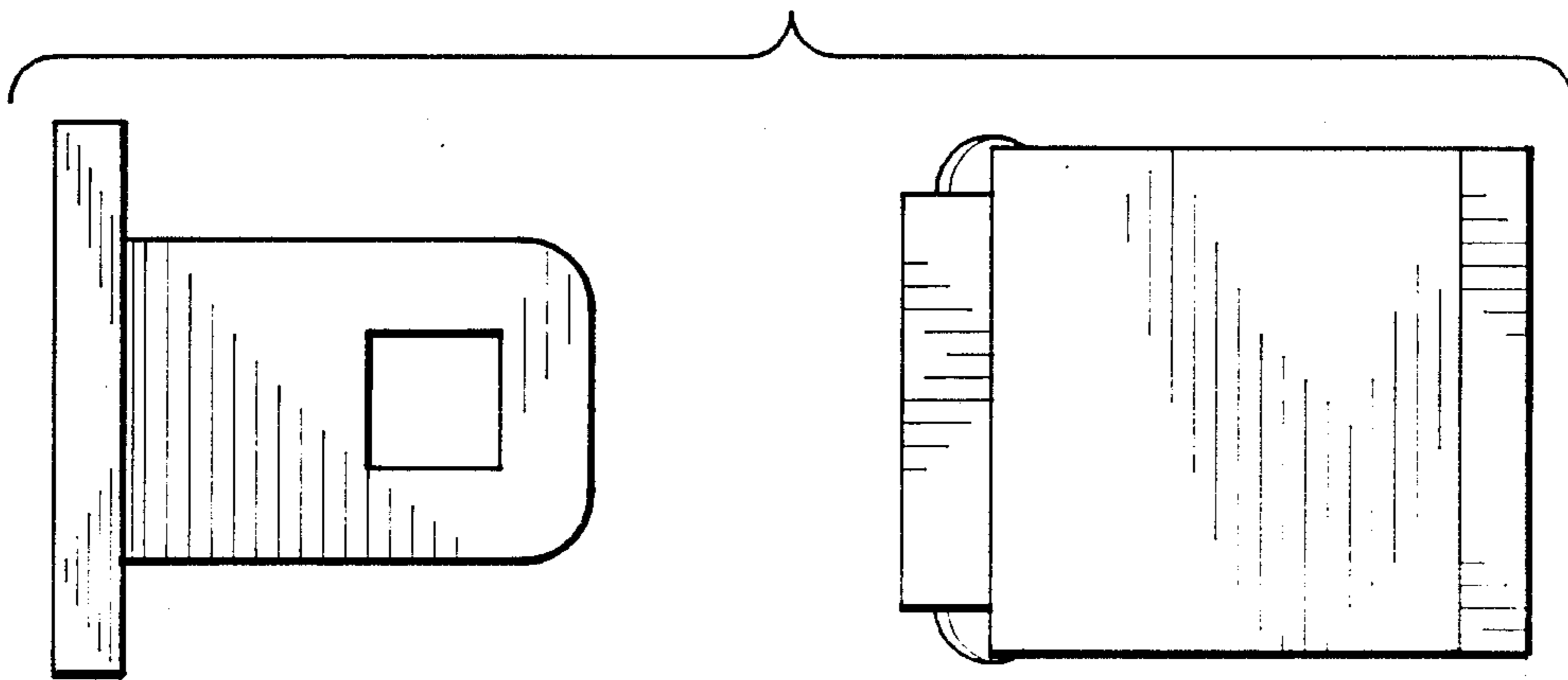

Fig. 6