

[54] **KITTY LITTER BOX**

[76] **Inventor: Eleanor A. Splane, 1649 S. Downing St., Seaside, Oreg. 97138**

[**] **Term: 14 Years**

[21] **Appl. No.: 76,556**

[22] **Filed: Jul. 22, 1987**

[52] **U.S. Cl. D30/161**

[58] **Field of Search D30/99, 158, 160, 161, D30/199, 108-120; 119/1, 17, 19, 29, 29.5, 158**

[56] **References Cited**

U.S. PATENT DOCUMENTS

D. 225,121	11/1972	Mashburn	119/1
640,730	2/1900	Smith	119/19
1,007,956	11/1911	Maurer	119/19
1,039,532	9/1912	Hays	119/19
3,460,516	8/1969	Leonard	119/19

Primary Examiner—Louis S. Zarfes
Attorney, Agent, or Firm—Kraus & Young

[57] **CLAIM**

The ornamental design for a kitty litter box, as shown and described.

DESCRIPTION

FIG. 1 is a perspective view of a kitty litter box showing my new design, the top flaps are in closed position; FIG. 2 is a perspective view showing one top flap in open position; and FIG. 3 is a perspective view showing both flaps in open position.

The box liner and cat shown in broken lines in FIG. 3 are for illustrative purposes only and form no part of the claimed design.

The rear and bottom views of the kitty litter box are not shown. The rear view of the kitty litter box is symmetric with and substantially identical to the front view of FIG. 3, having no additional ornamental features therein. The bottom of the kitty litter box is flat (as shown in cutaway in FIG. 3) and contains no ornamental features therein.

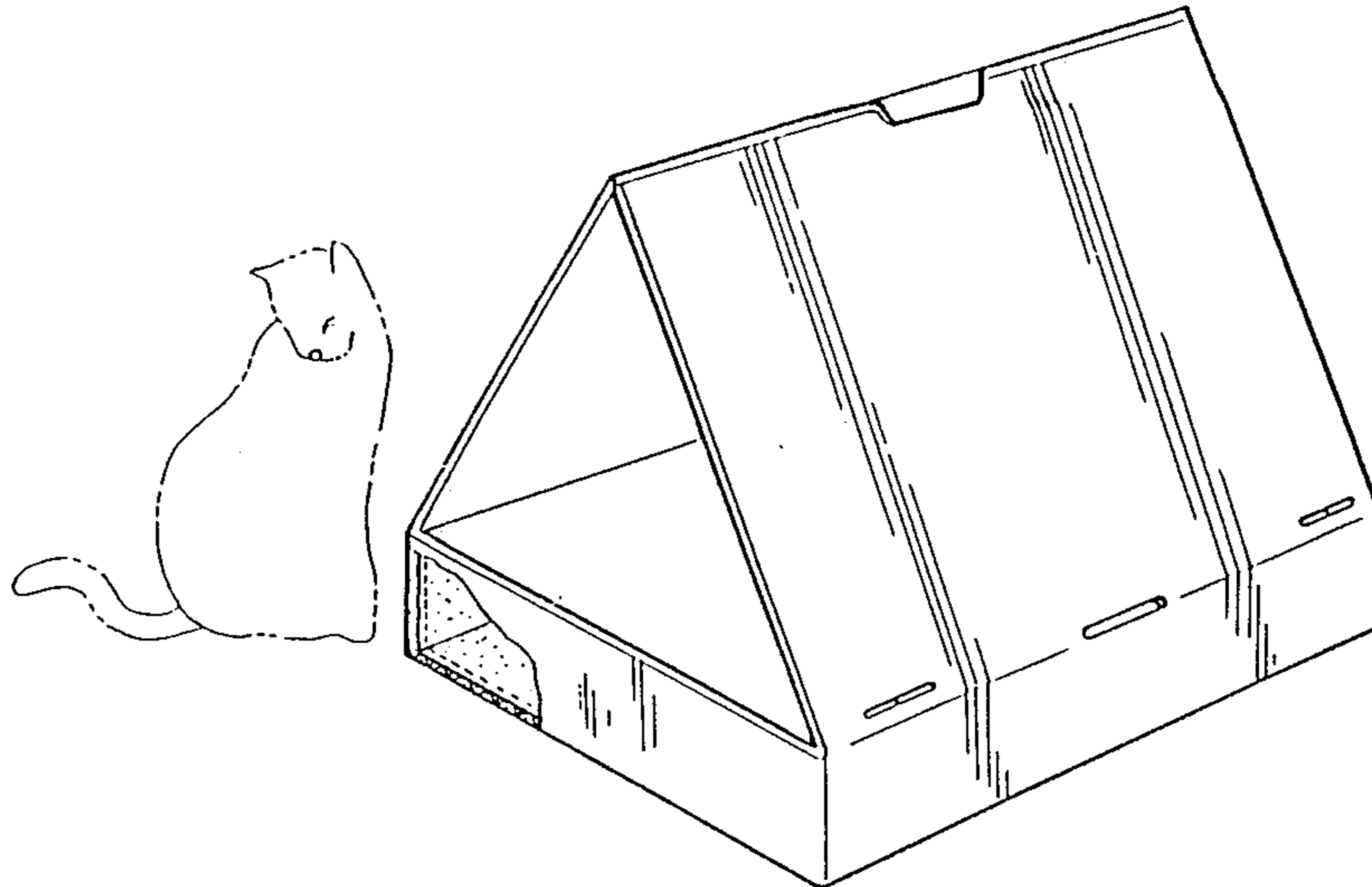

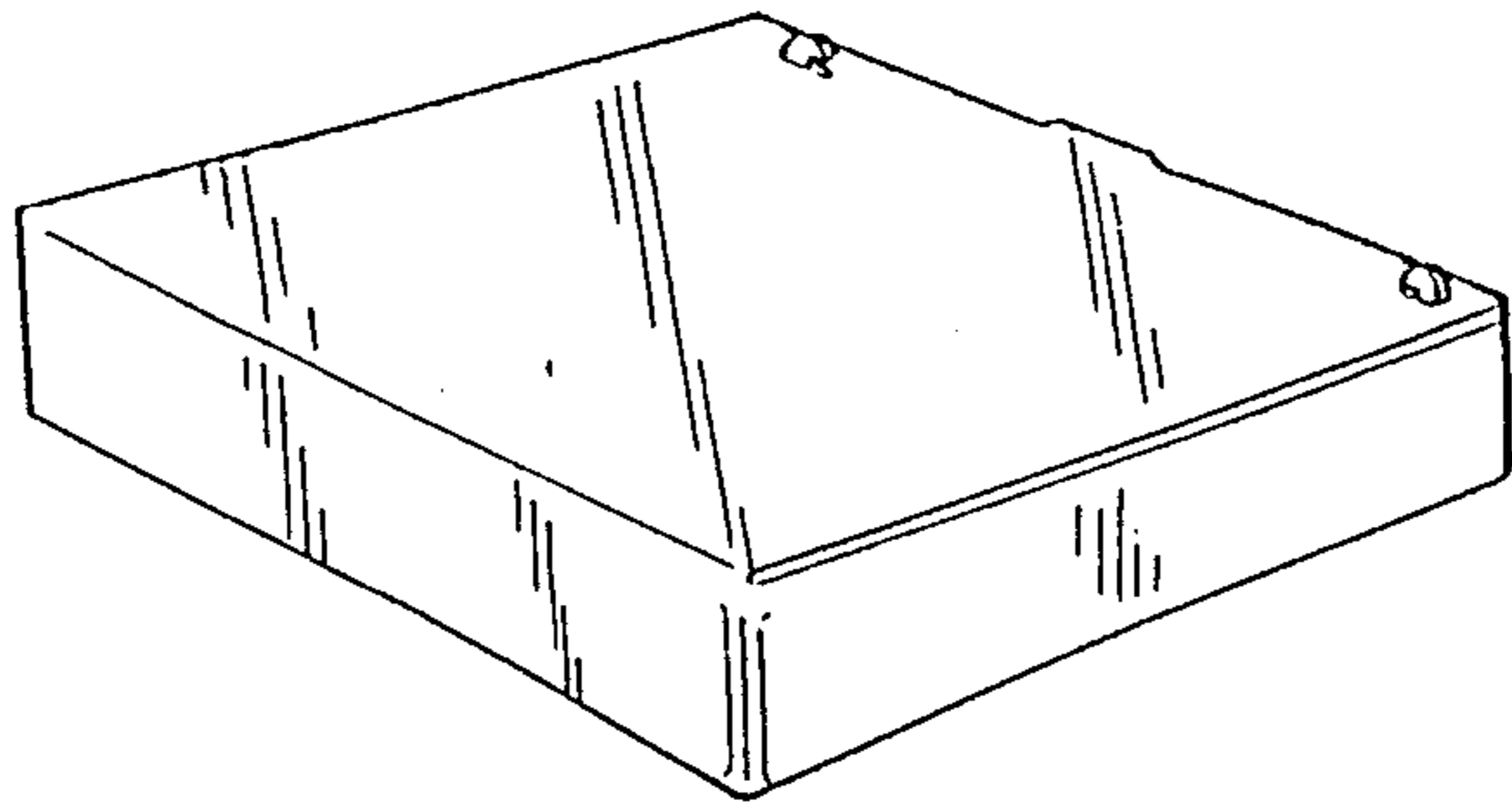

Fig-1

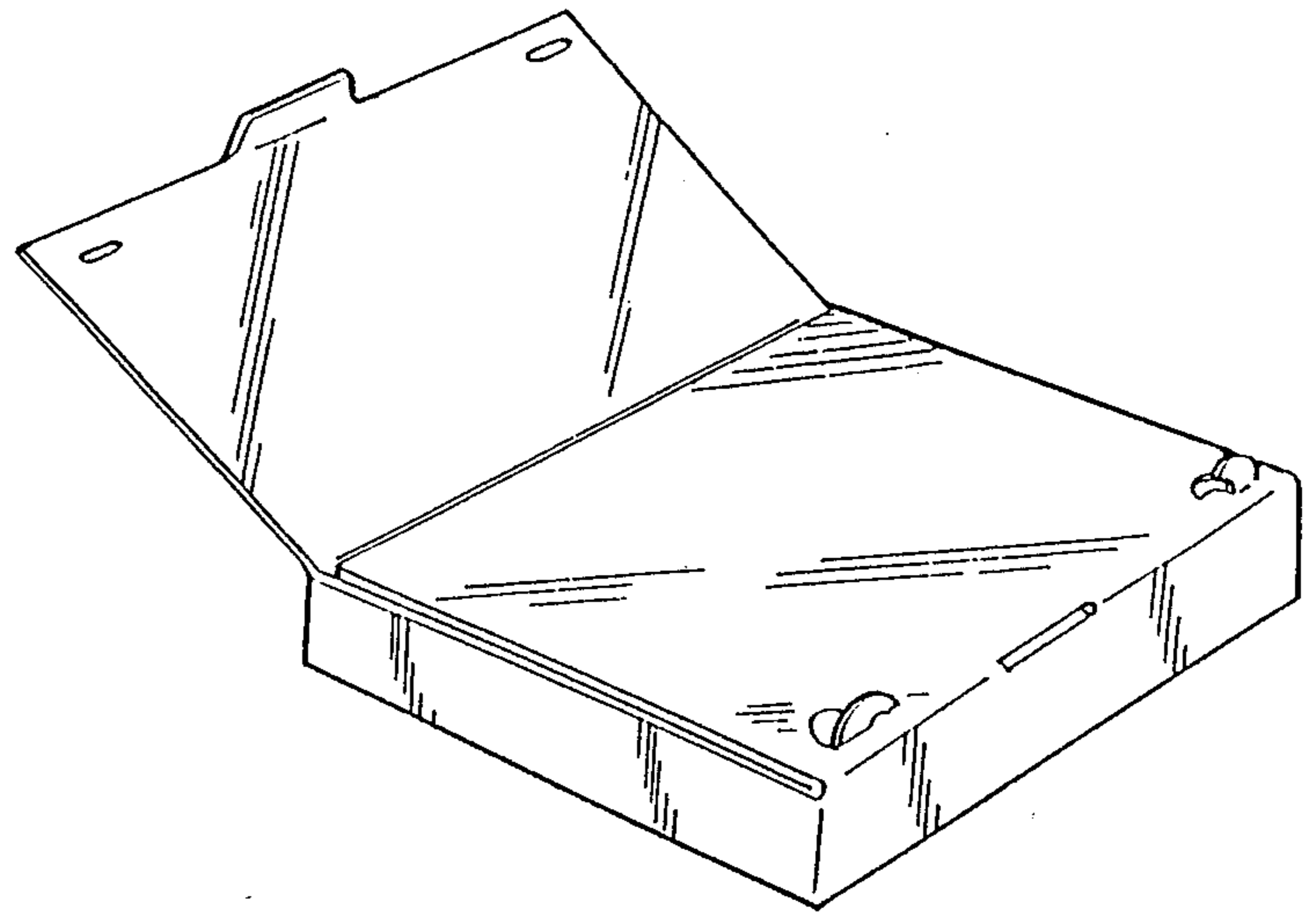

Fig-2

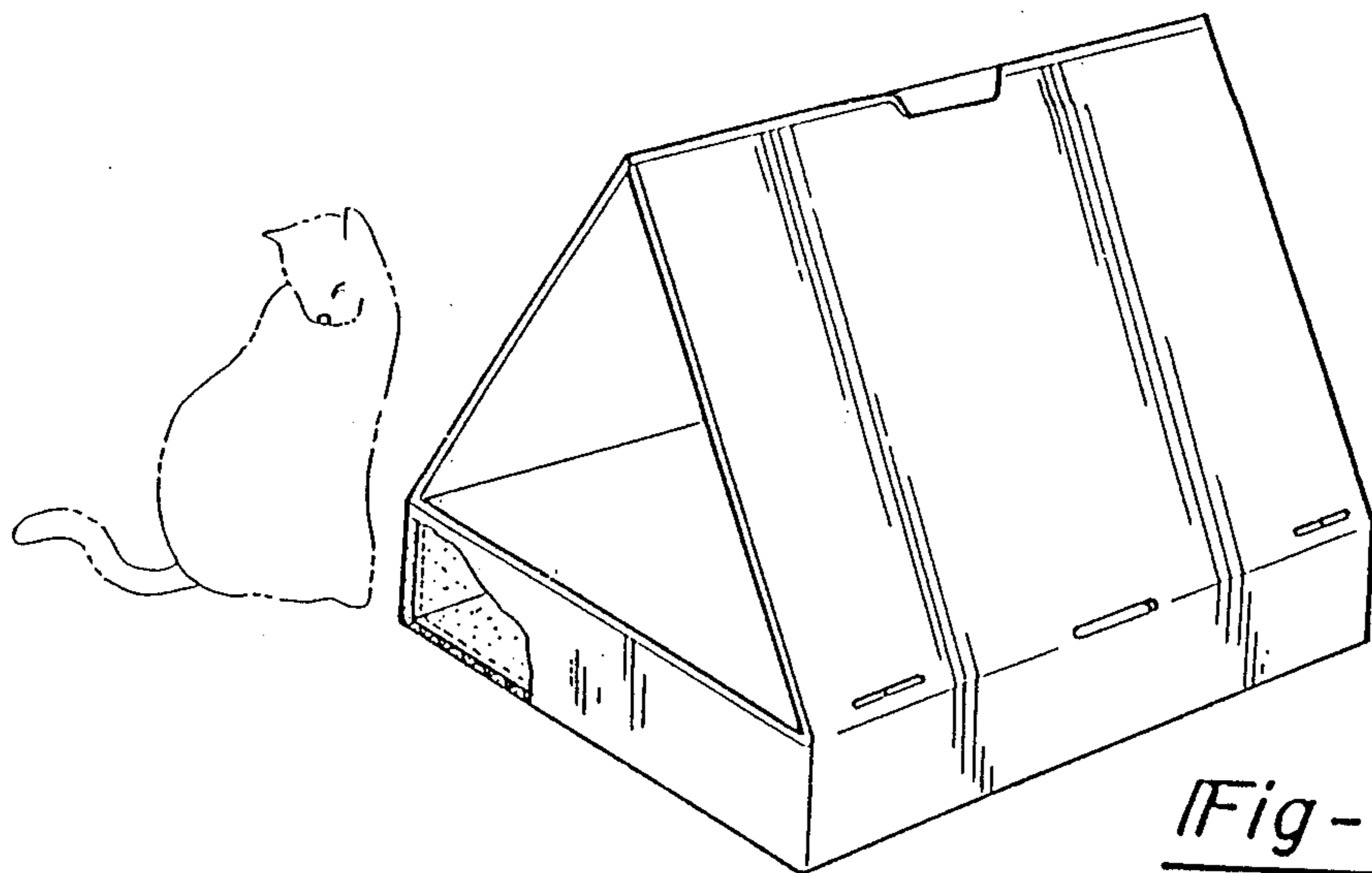

Fig-3