

[54] **BATHTUB FOR HANDICAPPED**

[76] Inventors: **Alan B. Eke**, 9407 Van Buren St., Blaine; **Daniel A. Eke**, 11846 - 16th La. NW., Coon Rapids, both of Minn. 55433; **Earl Johnson**, R.R. 1, Dunnell, Minn. 56127

[\*\*] Term: **14 Years**

[21] Appl. No.: **2,129**

[22] Filed: **Jan. 12, 1987**

[52] U.S. Cl. .... **D23/281**

[58] Field of Search ..... **D23/270-283, D23/303-307; D24/38, 39; 4/513, 538-544, 546, 559, 571-579, 584, 589, 590**

[56] **References Cited**

**U.S. PATENT DOCUMENTS**

D. 236,006	7/1975	Powell .....	D23/281
D. 236,619	9/1975	Powell .....	D23/281
D. 250,828	1/1979	Clement .....	D23/281
D. 250,830	1/1979	Clement .....	D23/277
D. 265,922	8/1982	Jasperson .....	D23/281
D. 273,700	5/1984	Parker .....	D23/282
3,559,216	2/1971	Kyte .....	4/540

3,827,087	8/1974	Cuthbertson .....	4/540
3,924,278	12/1975	Ekman .....	4/540
4,530,121	7/1985	Penney .....	4/540
4,809,368	3/1989	Johansson .....	4/540

*Primary Examiner*—James R. Largen  
*Attorney, Agent, or Firm*—Palmatier & Sjoquist

[57] **CLAIM**

The design for a bathtub for handicapped, as shown and described.

**DESCRIPTION**

FIG. 1 is a top plan view of a bathtub for handicapped showing my new design;  
FIG. 2 is a side elevational view thereof, the opposite side being a mirror image of the side shown;  
FIG. 3 is a cross sectional view taken on line 3—3 of FIG. 1;  
FIG. 4 is an end elevational view thereof;  
FIG. 5 is an elevational view showing the end opposite that shown in FIG. 4;  
FIG. 6 is a cross sectional view taken on line 6—6 of FIG. 1; and  
FIG. 7 is a cross sectional view taken on line 7—7 of FIG. 1.

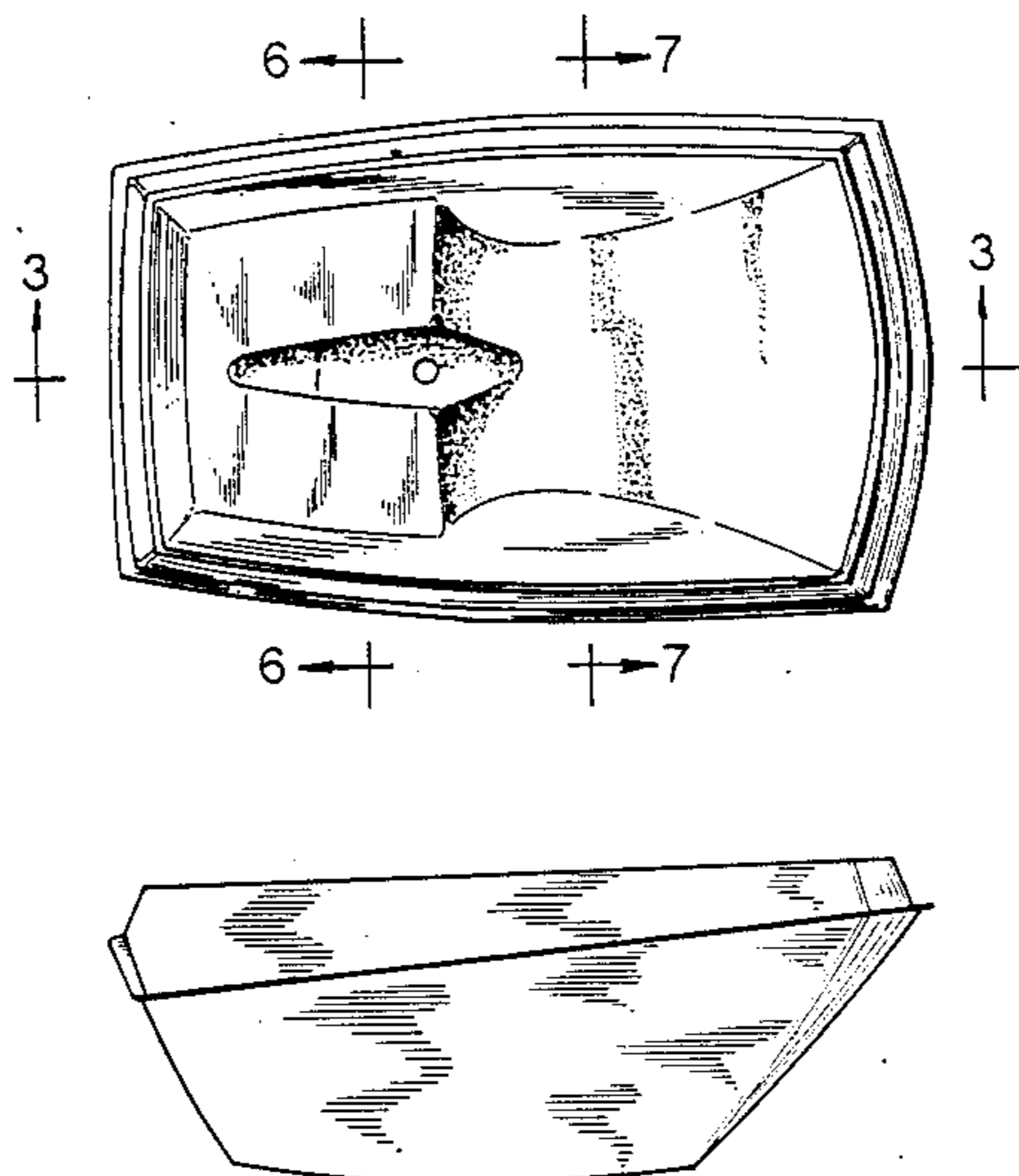

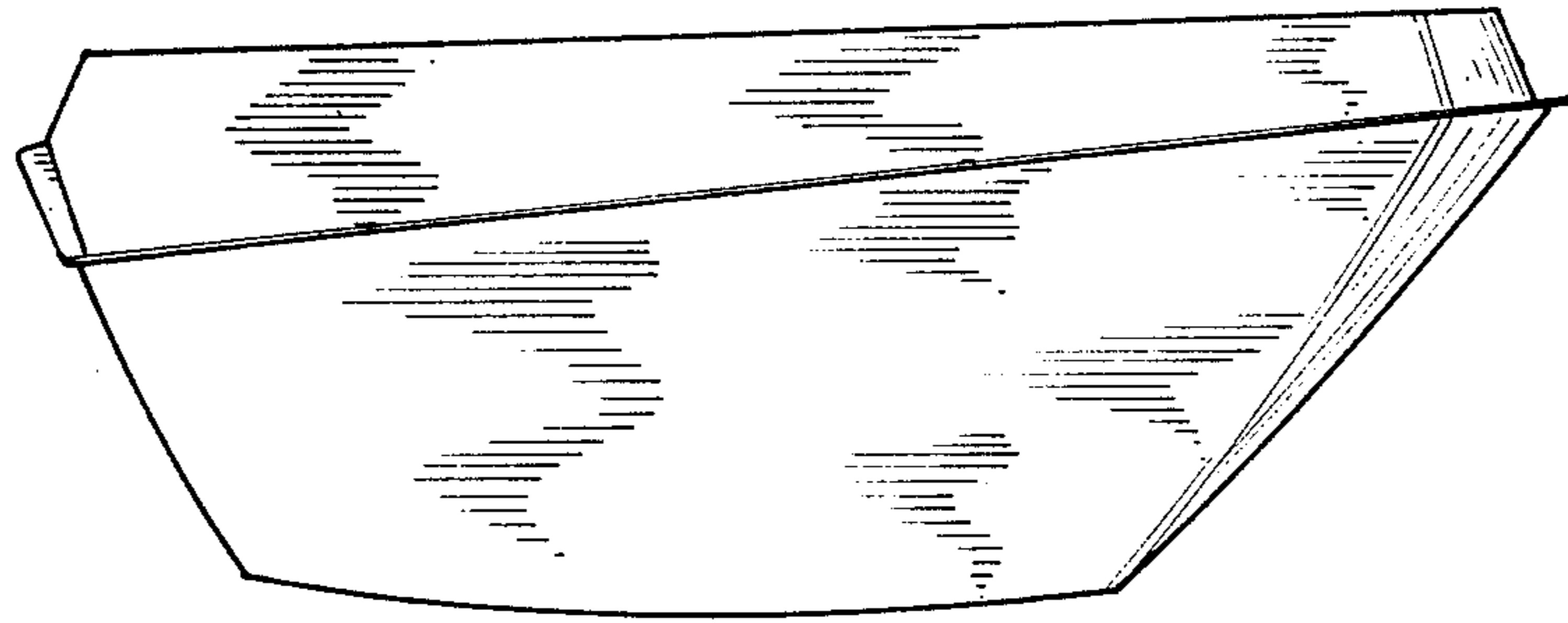
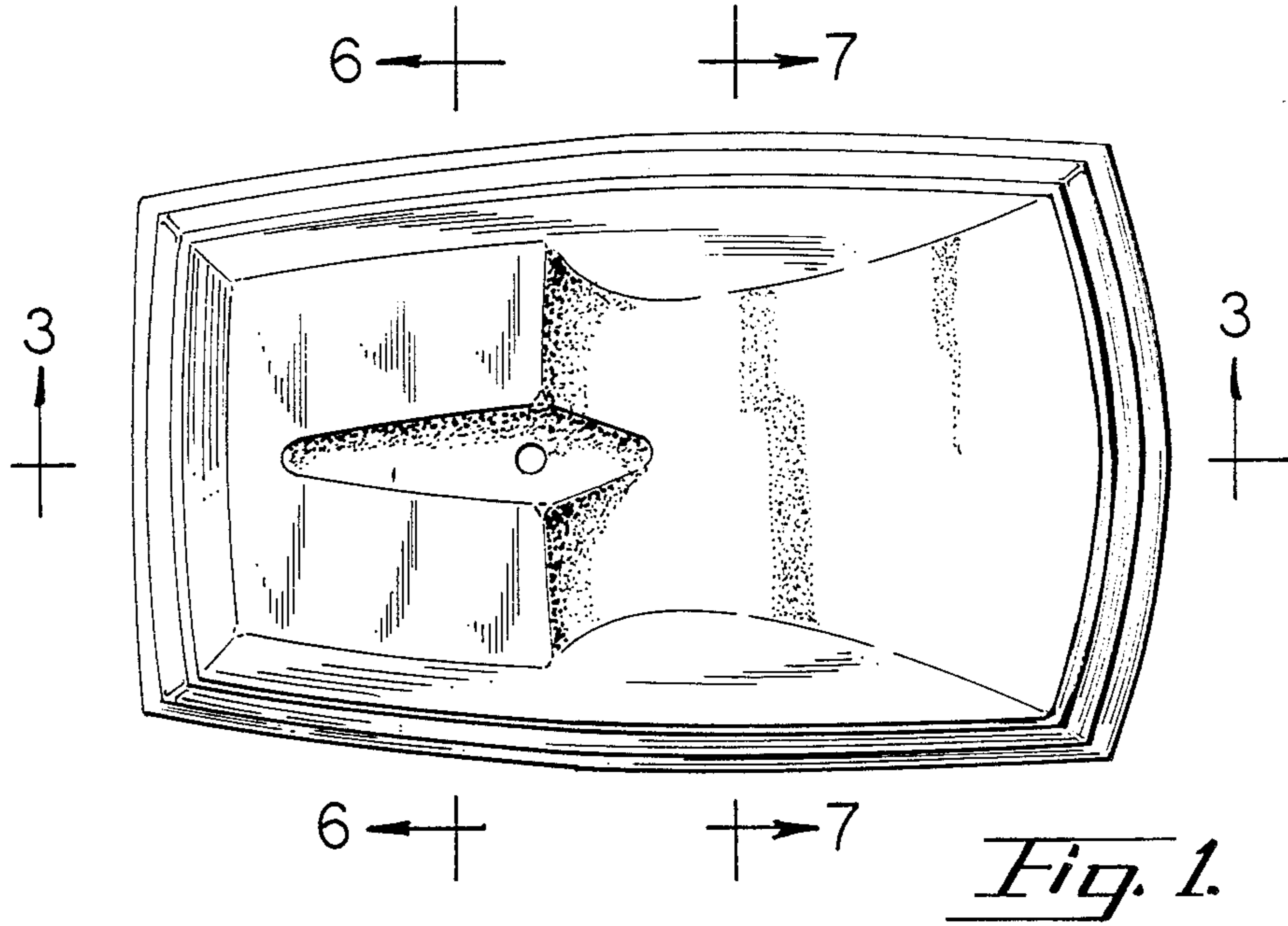

Fig. 2.

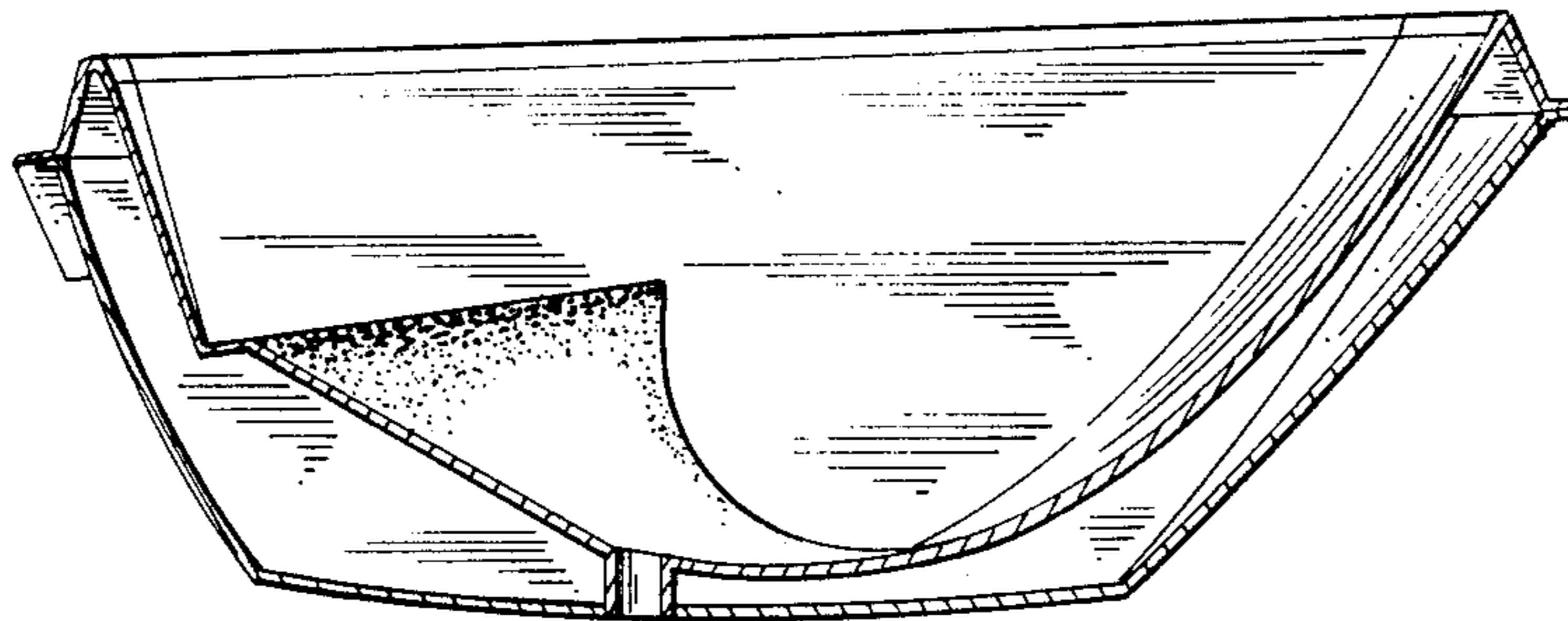
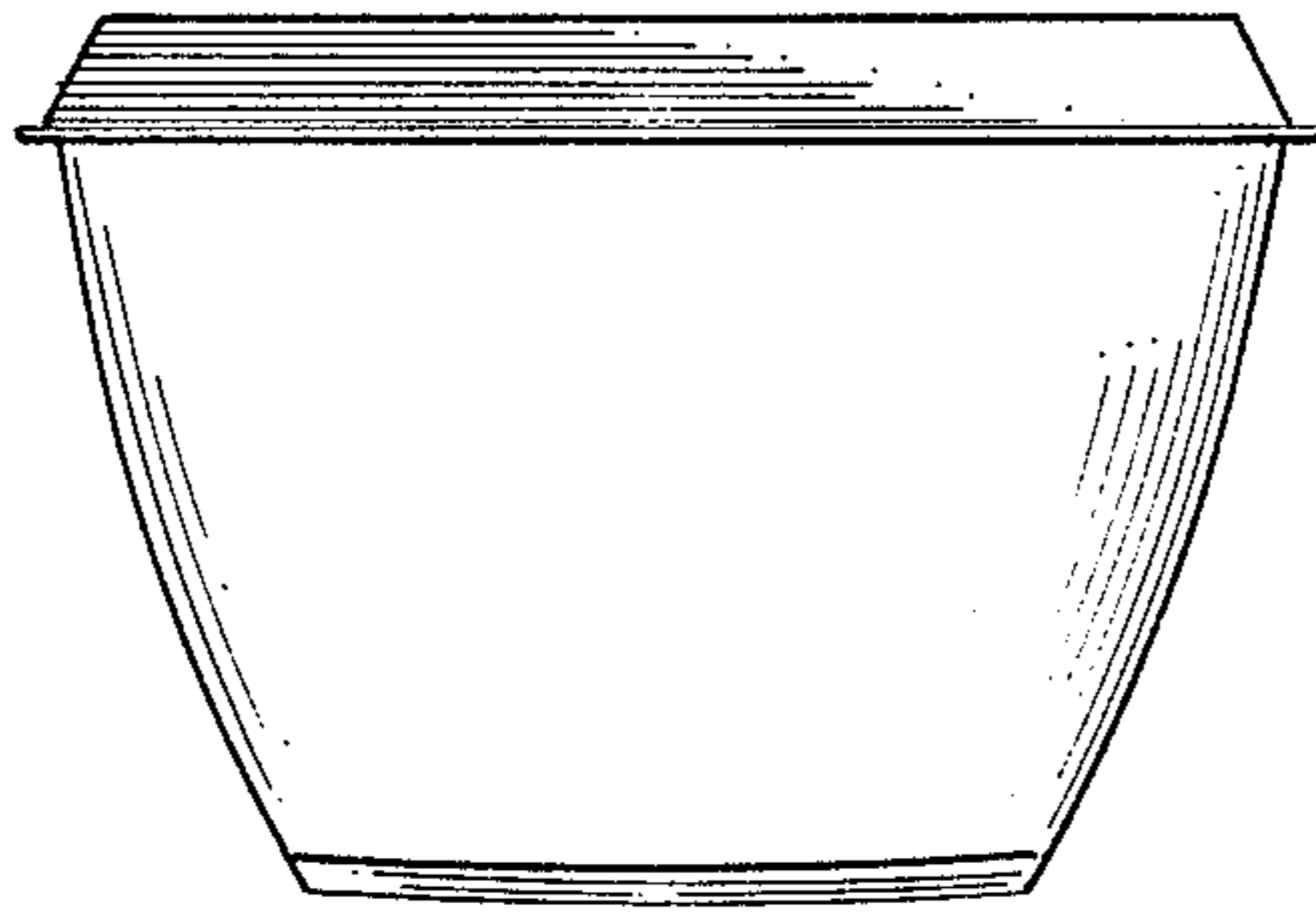
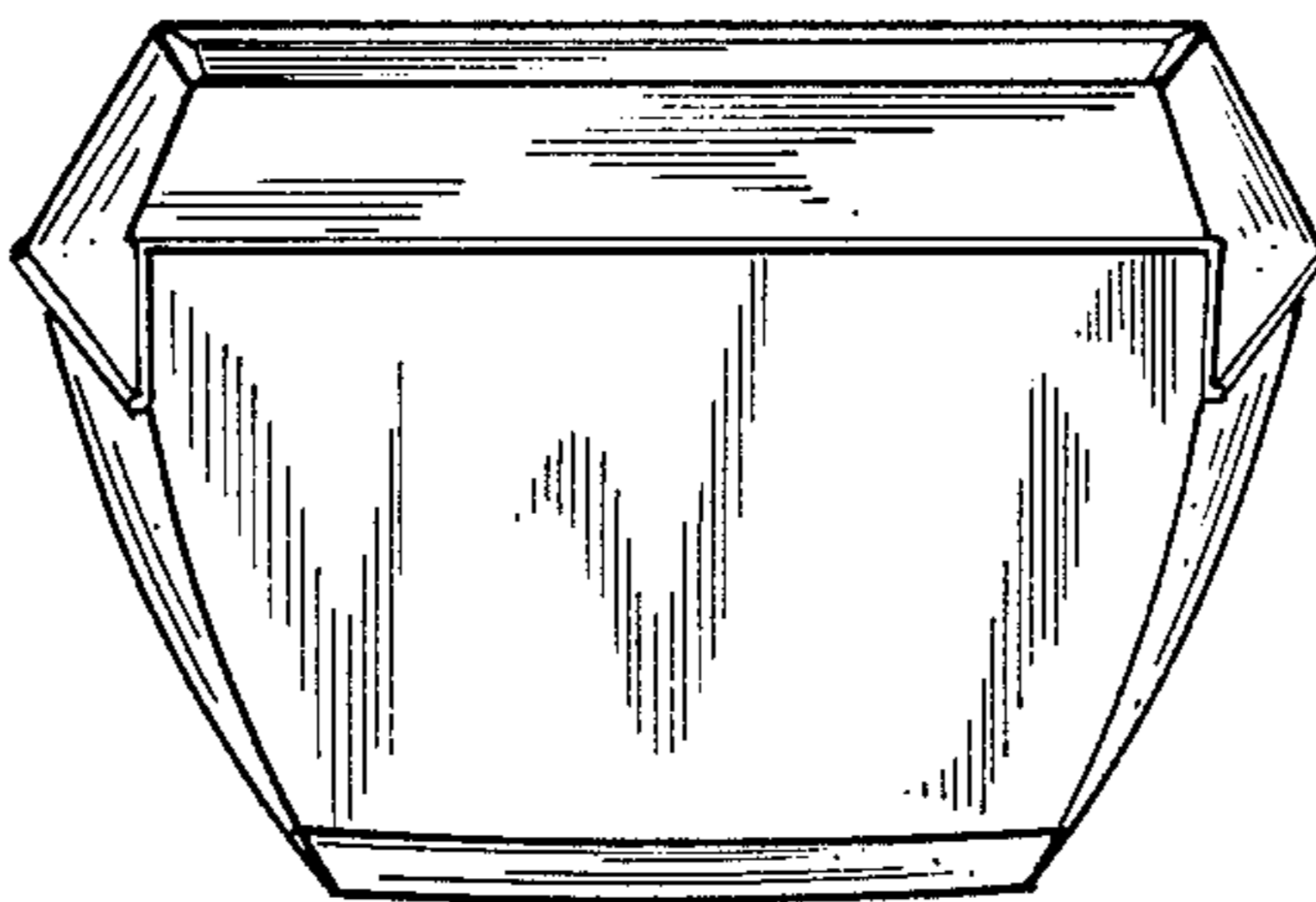

Fig. 3.



*Fig. 4.*



*Fig. 5.*

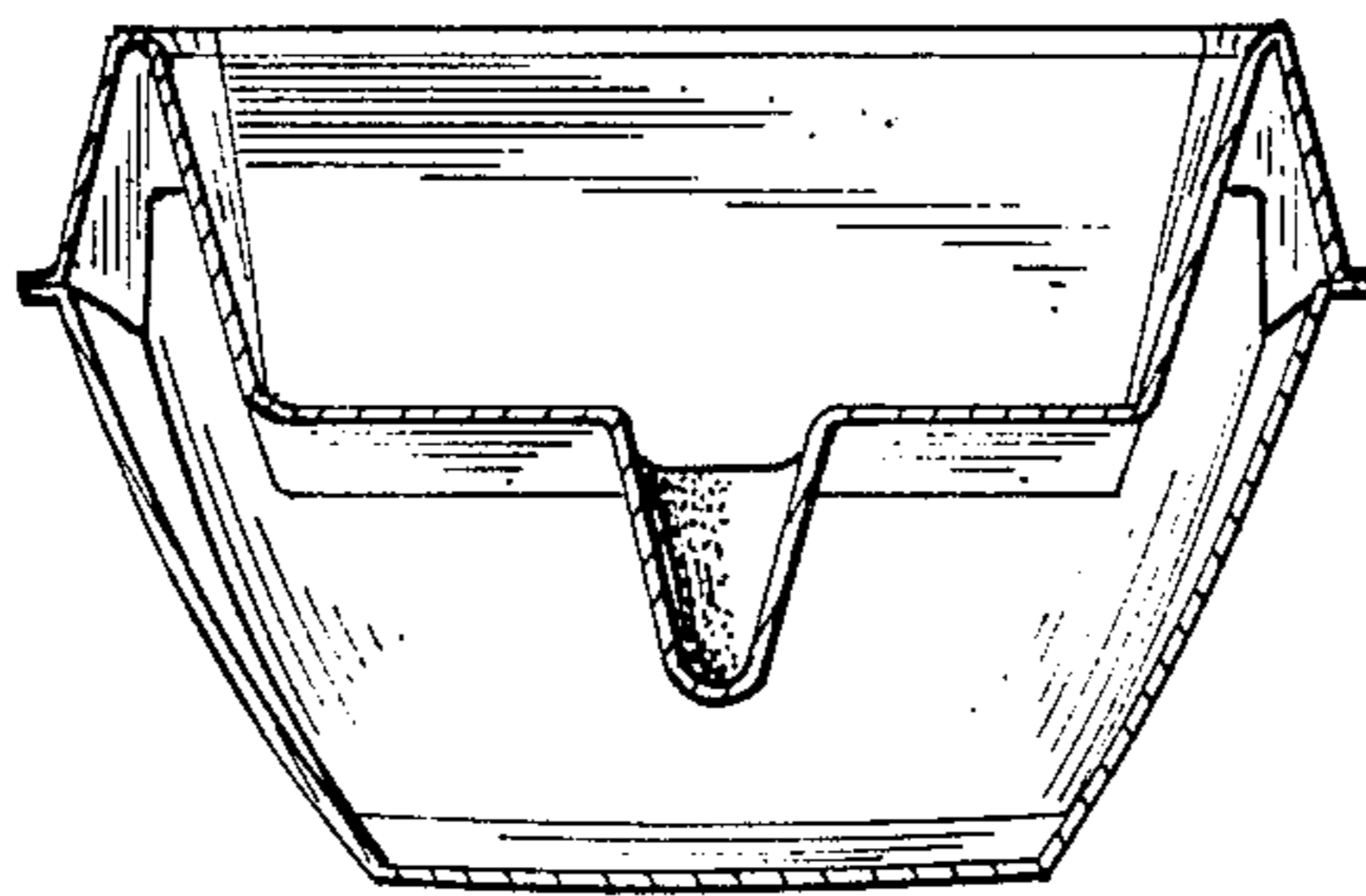

*Fig. 6.*

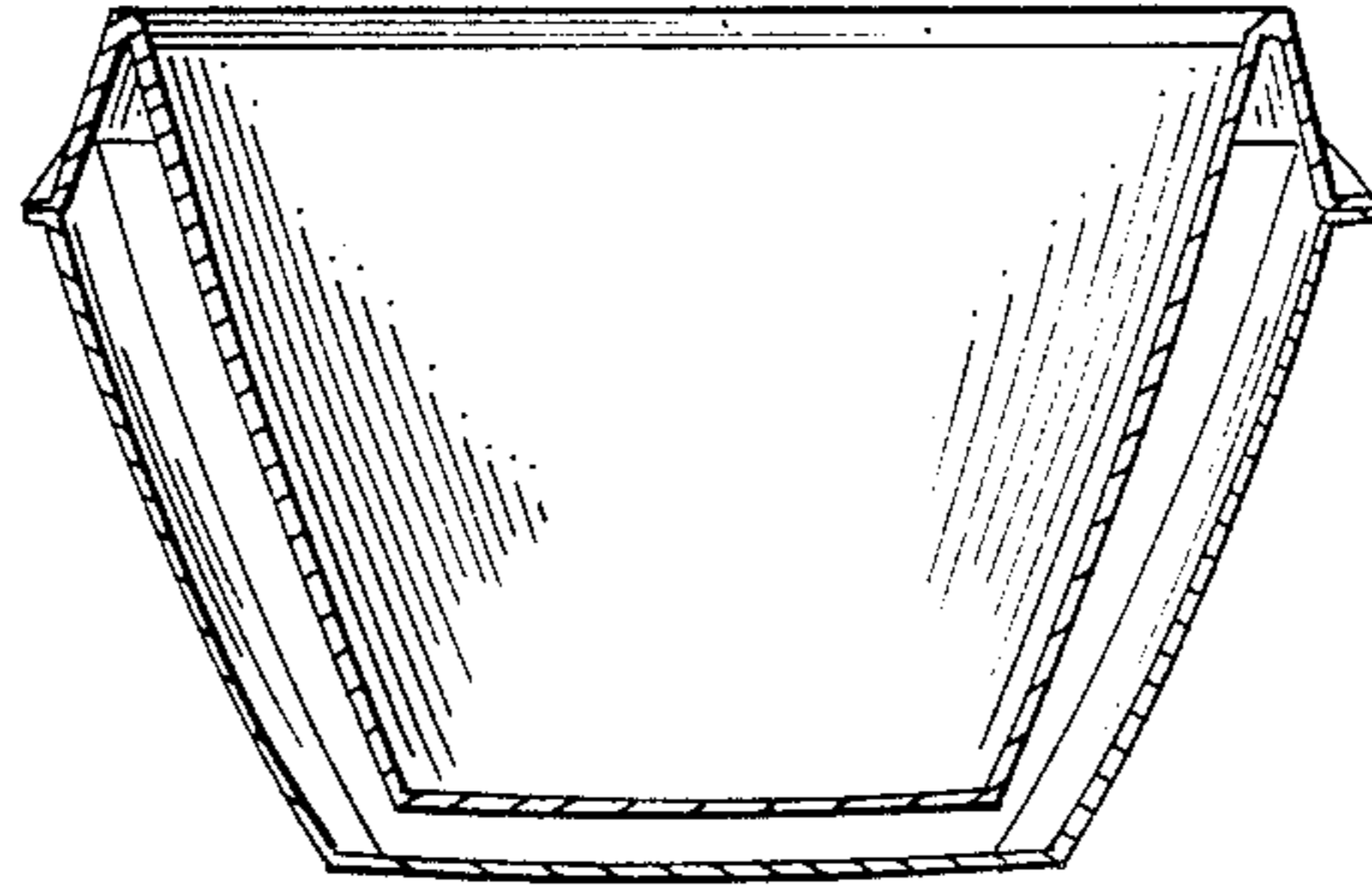

*Fig. 7.*